

realspace®

Pelingo  
Collection

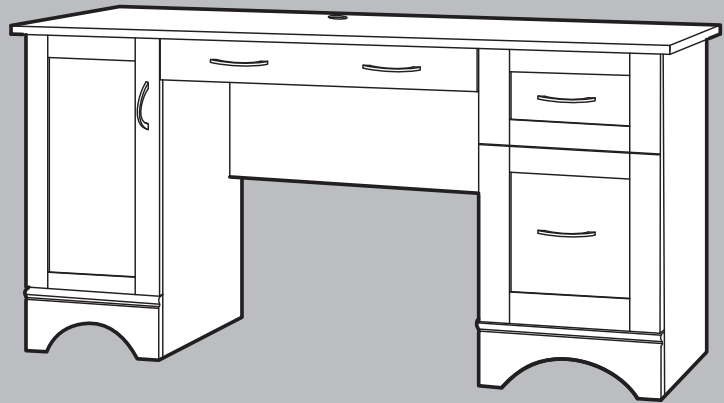

## Computer Desk

Assembly instructions and warranty information

## Bureau d'ordinateur

Instructions pour l'assemblage et information sur la garantie

## Escritorio para computadora

Instrucciones para el ensamblaje e información sobre la garantía

**For customer support, call 1-844-327-8600**

Pour le support client, appelez le 1 844 327-8600

Llame para asistencia al cliente 1-844-327-8600

Date Manufactured / Date de fabrication / Fecha de manufactura: \_\_\_\_\_

Lot # / Nombre de sort / Número de lote: \_\_\_\_\_

version 0321

Items 791-274, 161-324

Realspace is a registered trademark of The Office Club, Inc.  
© 2021 Office Depot, LLC. All Rights Reserved. Made in Vietnam

## **Warning**

**Please use your furniture correctly and safely. Improper use can cause safety hazards, or damage to your furniture or household items. Carefully read the following chart.**

<b>Look out for:</b>	<b>What can happen:</b>	<b>How to avoid:</b>
Children climbing on furniture. A child may try to reach a toy or other object by climbing on furniture. Children will play and be active near a TV.	Risk of injury or death. A child climbing on a piece of furniture or playing with a TV can cause it to tip over.	Never allow children to climb on or play with furniture. Do not place toys, food, etc. on the top shelves and/or drawers. Children may try to climb to reach them out of curiosity.
Overloaded drawers and/or shelves. Improper loading can cause furniture to be top-heavy.	Risk of injury or damage to furniture and/or equipment. Overloaded drawers and/or shelves can break.	Refer to your assembly manual for maximum weight capacities. Load drawers and shelves from the bottom to the top. Place heavier items in lower drawers and/or shelves. Unload drawers and shelves from the top to the bottom before moving the furniture.
Placing a TV on furniture that is not designed to support a TV.	Risk of injury or death. TVs can be very heavy. The weight and location of the picture tube tends to make them unbalanced and prone to tipping forward.	This product is not designed to support a TV.
Improperly moving furniture.	Risk of injury or damage to furniture and/or equipment. Furniture can tip over if not moved carefully over obstacles or across a changing floor surface (ex: from a wood floor to carpeted floor).	Do not push furniture, especially on carpeted floor. Have someone help you lift the item and place it in its new location. Remove any glass tops, shelves or doors before moving.

Thank you for purchasing this product. We trust that you will be completely satisfied with your product for years to come. This product is backed by a 5 year limited warranty and has been crafted with today's lifestyles in mind.

### **Call Us First!**

For immediate help with assembly or product information call our toll-free number:  
 1-844-327-8600 Mon-Fri 8am to 5:30pm CST.  
 Our staff is ready to provide assistance.  
 Damaged or missing parts ship from our facility in 1-2 business days.

### **The maximum recommended weight allowance is 200 lbs (91 kg) for top surface.**

The maximum recommended weight allowance is 10 lbs (4.5 kg) for drawers, 40 lbs (18.1 kg) for left cabinet, 30 lbs (13.6 kg) for file drawer. Lot # is located on a side panel. Please record it in space below for future reference. Record date of purchase below and save this booklet for future reference. Call for parts & service 1-844-327-8600. For customer support, Vendor Sticker can be found on the underside of the center crossbar (part list J).

**SPECIAL NOTE:** Please read the instruction sheets completely before assembly. Examine all packaging material before discarding carton. Remove any remaining staples from the carton before discarding. Select a smooth work surface which will not scratch or damage parts. Remove all parts from carton and separate into groups as indicated on parts list. Please ensure all parts are included prior to assembly. Use of power tools to complete assembly is not recommended.

**Customer Service 1-844-327-8600 & cs@homenationsinc.net**    Date Purchased: \_\_\_\_\_

## **Avertissement**

**Prière d'utiliser le mobilier à bon escient et avec prudence. Une mauvaise utilisation peut être à l'origine de risques d'accident ou peut endommager le mobilier et les articles ménagers. Lire attentivement le tableau suivant.**

<b>Faites attention :</b>	<b>Les risques :</b>	<b>Comment éviter :</b>
Enfants monter sur des meubles. Un enfant peut essayer d'atteindre un jouet ou tout autre objet en s'élevant sur des meubles. Les enfants vont jouer et être actifs à proximité du téléviseur.	Risque de blessures voire la mort. Un enfant s'élevant sur un meuble ou jouant avec une télé peut la faire incliner plus se renverser.	Ne laissez pas les enfants monter ou jouer près de la télé. Ne posez jamais de jouets, nourriture, etc. sur les étagères ou les tiroirs supérieurs. Les enfants pourraient tenter des les attraper par curiosité.
Etagères et/ou tiroirs surchargées. Le chargement impropre peut rendre des meubles instable.	Risque de blessures voire la mort ou dommages aux meubles et/ou au équipement. Etagères/tiroirs surchargées peuvent casser.	Ne jamais excéder les limites de poids indiquées dans les instructions. Charger l'étagères/tiroirs à partir du bas et finir au haut. Placer objets les plus lourds sur l'étagères/tiroirs inférieures. Déchargez les tiroirs et les étagères de haut en bas avant de déplacer les meubles.
Plaçant une télévision sur meubles qui ne sont pas conçus pour supporter une télévision.	Risque de blessures voire la mort. Les téléviseurs peuvent être tres lourds. Le poids et l'emplacement du tube image ont tendance à rendre les téléviseurs instables et enclins à tomber vers l'avant.	Ce produit n'est pas conçu pour supporter une télé.
Meubles qui sont déplacés incorrectement.	Risque de blessures voire la mort ou dommages aux meubles et/ou au équipement. Les meubles peuvent incliner en avant et casser si non déplacé soigneusement au-dessus des obstacles ou à travers une surface changeante (ex: d'un plancher en bois au plancher tapissé).	Ne poussez pas les meubles, en particulier sur un sol avec une moquette. Obtenez l'aide de quelqu'un pour soulever le meuble et placer dans son nouvel emplacement. Désassemblez toutes les tables, étagères ou portes de verre avant de se déplacer.

Nous vous remercions d'avoir acheté ce produit et espérons que vous en serez entièrement satisfait pendant de longues années. Ce produit est couvert par une garantie limitée de 5 ans et a été conçu pour répondre aux besoins d'aujourd'hui.

### **N'hésitez pas à nous appeler!**

Pour obtenir de l'aide lors du montage ou des informations sur le produit, veuillez appeler notre numéro sans frais : 1-844-327-8600, du lundi au vendredi, de 8 h à 17:30 h Heure Centrale. Notre personnel se fera un plaisir de vous fournir l'aide nécessaire.

Les pièces de rechange seront expédiées depuis notre unité de production dans un délai de 1 à 2 jours ouvrables.

### **Le panneau supérieur peut supporter un poids maximal de 91 kg (200 lb).**

La tiroir 4.5 kg (10 lb), cabinet de gauche 18.1 kg (40 lb), tiroir classeur 13.6 kg (30 lb) peut supporter un poids maximal. Le numéro de lot figure sur un panneau latéral. Veuillez l'inscrire dans l'espace ci-dessous à des fins de consultation future. Notez la date d'achat ci-dessous et enregistrez ce guide pour une utilisation ultérieure. Communiquez au besoin avec le service après-vente au 1 844 327 8600. Pour le service à la clientèle, vous trouverez l'autocollant avec les informations du fournisseur dans le du entretoise intermédiaire (liste des pièces J).

**REMARQUE :** Veuillez lire toutes les directives avant de procéder au montage. Examinez tout le matériel d'emballage avant de jeter le carton. Retirez les agrafes de ce dernier avant de le jeter. Choisissez une surface de travail lisse qui ne pourra ni égratigner ni endommager les pièces. Enlevez toutes les pièces du carton et répartissez-les en groupes tel qu'indiqué sur la liste des pièces. Assurez-vous que toutes les pièces ont été incluses avant de commencer le montage. L'utilisation d'outils électriques n'est pas recommandée pour le montage.

**Service à la clientèle : 1-844-327-8600 & cs@homenationsinc.net** Date d'achat : \_\_\_\_\_



## Advertencia

Por favor use su mueble correctamente y seguramente. El uso impropio puede causar riesgos de seguridad o daño al mueble o artículos domésticos. *Cuidadosamente lea la tabla a continuación.*

Tenga cuidado con:	Puede ocurrir:	Como evitar:
Niños subiéndose a los muebles. Un niño tratara de alcanzar un juguete u otro objeto subiéndose a los muebles. Niños muy activos que juegan cerca del televisor.	Riesgo de lesión o muerte. Un niño subiéndose a un mueble o jugando con el televisor puede causar que se caiga.	Nunca permita que lo niños se suban o jueguen con los muebles. No coloque juguetes, comida, etc. sobre las gavetas o repisas superiores. Los niños trataran de subirse para alcanzarlos o por curiosidad.
Gavetas y repisas con sobrelleno. Colocando objetos de forma incorrecta puede causar el mueble ser inestable.	Riesgo de lesión o muerte o daño al mueble y equipo. Gavetas y repisas con sobrelleno se pueden romper.	Consulte sus instrucciones para el peso maximo permitido. Coloque artículos dentro de las gavetas o sobre las repisas empezando de abajo hacia arriba. Coloque los objetos más pesados en las gavetas o repisas inferiores. Descargue las gavetas y repisas empezando de arriba hacia abajo antes de mover el mueble.
Colocando un televisor sobre un mueble que no es diseñado para un televisor.	Riesgo de lesión o muerte. El televisor puede ser muy pesado. El peso y la localización del tubo de la pantalla lo hace estar fuera de balance y propensa a volcarse.	Este producto no es diseñado para un televisor.
Moviendo muebles de forma incorrecta.	Riesgo de lesión o muerte o daño al mueble y equipo. El mueble puede volcarse o romperse cuando se mueve de forma incorrecta sobre obstáculos o sobre un piso desnivelado (ejemplo: sobre un piso de madera a un piso alfombrado).	No empuje el mueble especialmente sobre la alfombra. Consiga que alguien le ayude a levantar el mueble para poder colocarlo en su lugar. Desensamble cualquier mesa, estante o puerta de vidrio antes de mover.

Le damos las gracias por adquirir este producto. Confiamos en que quede completamente satisfecho con sus prestaciones. Este producto tiene una garantía limitada de 5 años y ha sido creado atendiendo al estilo de vida de hoy día.

### ¡LLÁMENOS!

Si desea más información sobre el montaje, llámenos sin coste adicional alguno al siguiente teléfono de 8 de la mañana a 5:30 de la tarde de lunes a viernes (hora del Centro de EE. UU.): +1-844-327-8600 Nuestro personal le proporcionará toda la ayuda que necesite.

Las piezas dañadas o no adjuntadas saldrán de nuestras instalaciones en uno o dos días hábiles.

### El peso máximo recomendado es de 91 kg (200 libras) en el tablero.

El peso máximo recomendado es de 4.5 kg (10 libras) en el cajón, 18.1 kg (40 libras) en el Izquierda gabinete, 13.6 kg (30 libras) en el gaveta de archivos. El lote # está ubicado en un panel lateral. Anótelos en el espacio siguiente para poder consultarlo en el futuro. Anote la fecha de compra en el espacio a continuación y guarde este documento para poder consultarlo. El teléfono de asistencia y repuestos es 1-844-327-8600. Para servicio al cliente, encontrará la etiqueta con las informaciones del proveedor en la parte del soporte del centro la parte inferior (lista de piezas J).

**NOTA:** Lea atentamente toda la hoja de instrucciones antes de comenzar el montaje. Antes de deshacerse del embalaje compruebe que no ha olvidado nada en su interior. Seleccione una superficie de trabajo lisa que no raye ni dañe las partes. Quite cualquier grapa u accesorio fijado al cartón antes de tirarlo. Una vez apartadas las piezas, sepárelas en grupos como se indica en la lista. Cerciórese de que tiene todas las piezas antes de comenzar el ensamblaje. No se recomienda utilizar herramientas muy potentes para ensamblar este mueble.

**Nuestro teléfono de atención al cliente es +1-844-327-8600  
& cs@homenationsinc.net**

Fecha de compra: \_\_\_\_\_

## PARTS LIST

## LISTE DES PIÈCES











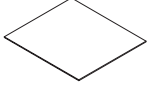
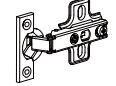
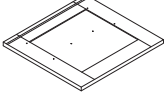

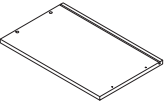
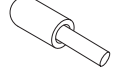
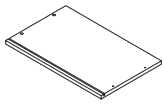
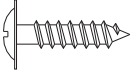
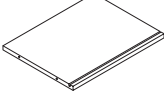
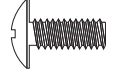
## LISTA DE PIEZAS

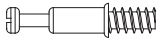
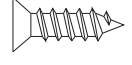
Name Nom Nombre	Part Pièce Pieza	Qty. Qté Cantidad	Name Nom Nombre	Part Pièce Pieza	Qty. Qté Cantidad
A	Top Panel Panneau supérieur Panel superior	1	N	Right Front Panel Panneau Droite Avant Panel Delantero Derecho	1
B	Left Panel Panneau Gauche Panel Izquierdo	1	O	Door Porte Puerta	1
C	Left Partition Cloison Gauche Partición Izquierdo	1	P	Adjustable Shelf Repisa ajustable Tabletteréglable	1
D	Right Partition Cloison Droite Partición Derecho	1	Q	Large Drawer Front Devant de Grand Tiroir Cara de Cajón Grande	1
E	Right Panel Panneau Droite Panel Derecho	1	R	Large Drawer Left Side Côté Gauche de Grand Tiroir Lado Izquierdo de Cajón Grande	1
F	Left Bottom Panneau Gauche Inférieure Izquierda Inferior Base	1	S	Large Drawer Right Side Côté Droit de Grand Tiroir Lado Derecho de Cajón Grande	1
G	Modesty Panel Voile De Fond Velo De Fondo	1	T	Large Drawer Back Arrière de Grand Tiroir Dorso de Cajón Grande	1
D1	Right Bottom Panneau Droite Inférieure Derecho Inferior Base	2	U	Large Drawer Bottom Fond de Grand Tiroir Inferior de Cajón Grande	1
I	Right Crossbar Entretoise Droite Soporte Derecho	1	V	Large Drawer Bottom Support Support de Fond de Grand Tiroir Soporte del Inferior de Cajón Grande	1
J	Center Crossbar Entretoise intermédiaire Soporte del Centro	1	W	Drawer Front Devant De Tiroir Cara De Cajón	1
K	Left Back Panel Panneau Gauche Arrière Panel Trasero Izquierdo	1	X1	Drawer Left Side Côté Gauche de Tiroir Lado Izquierdo de Cajón	1
L	Right Back Panel Panneau Droite Arrière Panel Trasero Derecho	1	Y1	Drawer Right Side Côté Droit de Tiroir Lado Derecho de Cajón	1
M	Left Front Panel Panneau Gauche Avant Panel Delantero Izquierdo	1	Z1	Drawer Back Arrière De Tiroir Dorso De Cajón	1

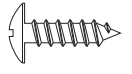
## PARTS LIST

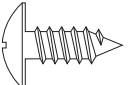
## LISTE DES PIÈCES

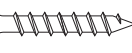
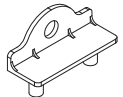

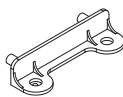
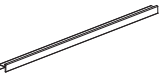
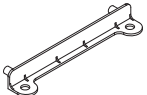
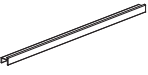
## LISTA DE PIEZAS

Name Nom Nombre	Part Pièce Pieza	Qty. Qté Cantidad	Spare Épargner Sobrante	Name Nom Nombre	Part Pièce Pieza	Qty. Qté Cantidad	Spare Épargner Sobrante		
N1	Drawer Bottom Fond de Tiroir Inferior de Cajón		2		9	Hinge Ferrure de rotation Bisagra		2	
BB	File Drawer Front Devant de Tiroir Classeur Cara del Cajón de Archivos		1		10	Grommet Ojete de plástico Oeillet		1	
K1	File Drawer Left Side Côté Gauche de Tiroir Classeur Lado Izquierdo del Cajón de Archivos		1		11	Shelf Support Support de Tablette Soporte de Estante		4	
L1	File Drawer Right Side Côté Droit de Tiroir Classeur Lado Derecho del Cajón de Archivos		1		12	Φ3 * 9/16" Large Head Screw Vis Tête Large Φ3 * 15mm Tornillo de Cabeza Grande de Φ3 * 15mm		22	2
M1	File Drawer Back Arrière de Tiroir Classeur Dorso del Cajón de Archivos		1		13	Φ4 * 3/8" Bolt Boulon de Φ4 * 10mm Perno de Φ4 * 10mm		4	
1	Cam Lock Serrure à Came Cierre de Leva		27	2	14	Φ4 * 3/4" Bolt Boulon de Φ4 * 19mm Perno de Φ4 * 19mm		6	
2	Cam Bolt Vis d'excentrique Perno de Leva		27	2	15	Φ3.5 * 1/2" Flat Head Screw Vis à Tête Plate de Φ3.5 * 12mm Tornillo del Cabeza Plana de Φ3.5 * 12mm		20	1
3	Wood Dowel Cheville en bois Pasador de Madera		27	2	16	Φ3.5 * 1/2" Screw Vis de Φ3.5 * 12mm Tornillo de Φ3.5 * 12mm		28	2
4	Handle Poignée Manija		5		17	Φ5 * 1/2" Screw Vis de Φ5 * 12mm Tornillo de Φ5 * 12mm		10	1
5	Plastic Corner Bracket Fixation d'angle en plastique Ménsula plástica en L		8		18	Φ5 * 1-1/4" Screw Vis de Φ5 * 32mm Tornillo de Φ5 * 32mm		14	
6	Short Panel Connector Connecteur de panneau court Conector del corto de paneles		2		19	File Hanger Support de dossiers Colgador de carpetas de archivo		1	
7	Panel Connector Connecteur de panneau Conector de paneles		2		20	Long File Rail Rail à Dossiers Long Largo el Archivo Rail		2	
8	Long Panel Connector Connecteur de panneau long Conector del largo de paneles		2		21	Short File Rail Rail à Dossiers Courte Corta el Archivo Rail		1	



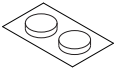
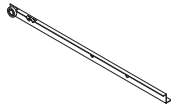
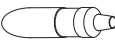
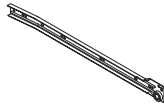
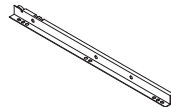

## PARTS LIST

## LISTE DES PIÈCES

## LISTA DE PIEZAS

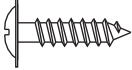
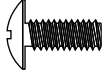
Name Nom Nombre	Part Pièce Pieza	Qty. Qté Cantidad	Spare Épargner Sobrante	Name Nom Nombre	Part Pièce Pieza	Qty. Qté Cantidad	Spare Épargner Sobrante
22	Plastic Cap Capuchons En Plastique Tapones De Plástico 	4	1	25a Left Cabinet Rail Glissière Gauche d'élément Riel Izquierdo de Gabinete		1	
23	Bumper Card Fiche Avec Tampons Tarjeta Con Topes 	1		25b Left Drawer Slide Coulisse Gauche de Tiroir Corredera Izquierda De Cajón		1	
24	Glue Colle Pegamento 	2		25c Right Cabinet Rail Glissière Droite d'élément Riel Largo Derecho De Gabinete		1	
				25d Right Drawer Slide Coulisse Droite de Tiroir Corredera Derecha de Cajón		1	

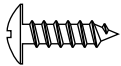
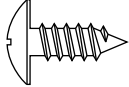
**SIZE COMPARISON CHART**  
**TABLEAU DE COMPARAISON DE TAILLES**  
**TABLA DE COMPARACIÓN DE TAMAÑOS**

<p><b>12</b></p>	<p>Φ3 * 9/16" Large Head Screw          Vis Tête Large Φ3 * 15mm          Tornillo de Cabeza Grande de Φ3 * 15mm</p>	
<p><b>13</b></p>	<p>Φ4 * 3/8" Bolt          Boulon de Φ4 * 10mm          Perno de Φ4 * 10mm</p>	
<p><b>14</b></p>	<p>Φ4 * 3/4" Bolt          Boulon de Φ4 * 19mm          Perno de Φ4 * 19mm</p>	
<p><b>15</b></p>	<p>Φ3.5 * 1/2" Screw          Vis de Φ3.5 * 12mm          Tornillo de Φ3.5 * 12mm</p>	
<p><b>16</b></p>	<p>Φ3.5 * 1/2" Screw          Vis de Φ3.5 * 12mm          Tornillo de Φ3.5 * 12mm</p>	
<p><b>17</b></p>	<p>Φ5 * 1/2" Screw          Vis de Φ5 * 12mm          Tornillo de Φ5 * 12mm</p>	
<p><b>18</b></p>	<p>Φ5 * 1-1/4" Screw          Vis de Φ5 * 32mm          Tornillo de Φ5 * 32mm</p>	



### Installation of Cams and Pins :

Screw the Pin into hole. To set Cams correctly, ensure the arrow on the Cam head points to the hole of the Pin it is locking. Lock Cam by turning Cam head one third clockwise with screwdriver. Do not overtighten. Please don't use an electric screwdriver to assemble the unit.

### Installation des roulettes à blocage et des chevilles :

Vissez la cheville à l'intérieur du trou. assurez-vous que la flèche sur le dessus de la roulette pointe vers le trou de la cheville à bloquer. Verrouillez la roulette à blocage en tournant le dessus de la roulette d'un tiers de tour en sens horaire à l'aide d'un tournevis. Ne serrez pas trop. Veuillez ne pas utiliser un tournevis électrique pour assembler ce meuble.

### Instalación de levas y pernos :

Atornille el pasador en el agujero, asegúrese de que la flecha en la cabeza de la leva apunta hacia el agujero del pasador que esta asegurando. Asegure la leva girando la cabeza un tercio en el sentido de las agujas del reloj. No la apriete en exceso. No utilice un destornillador eléctrico para ensamblar la unidad.

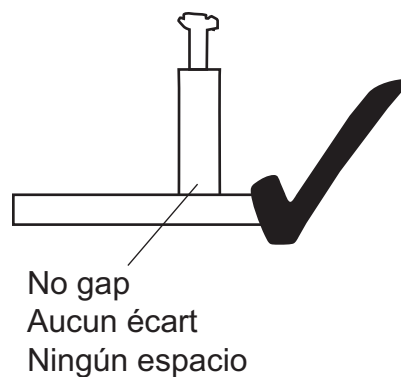
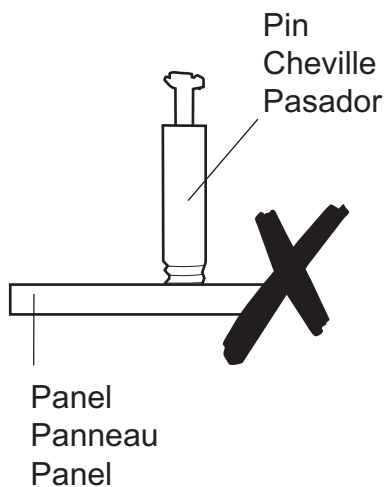
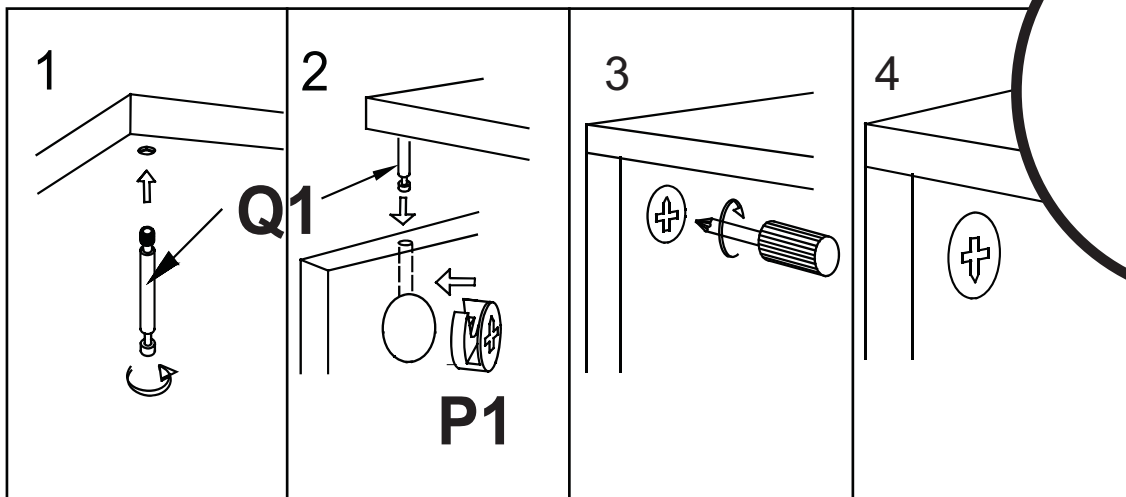

# 1

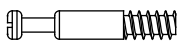
2  x 2

3  x 6

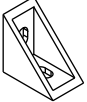
5  x 3

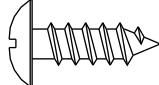

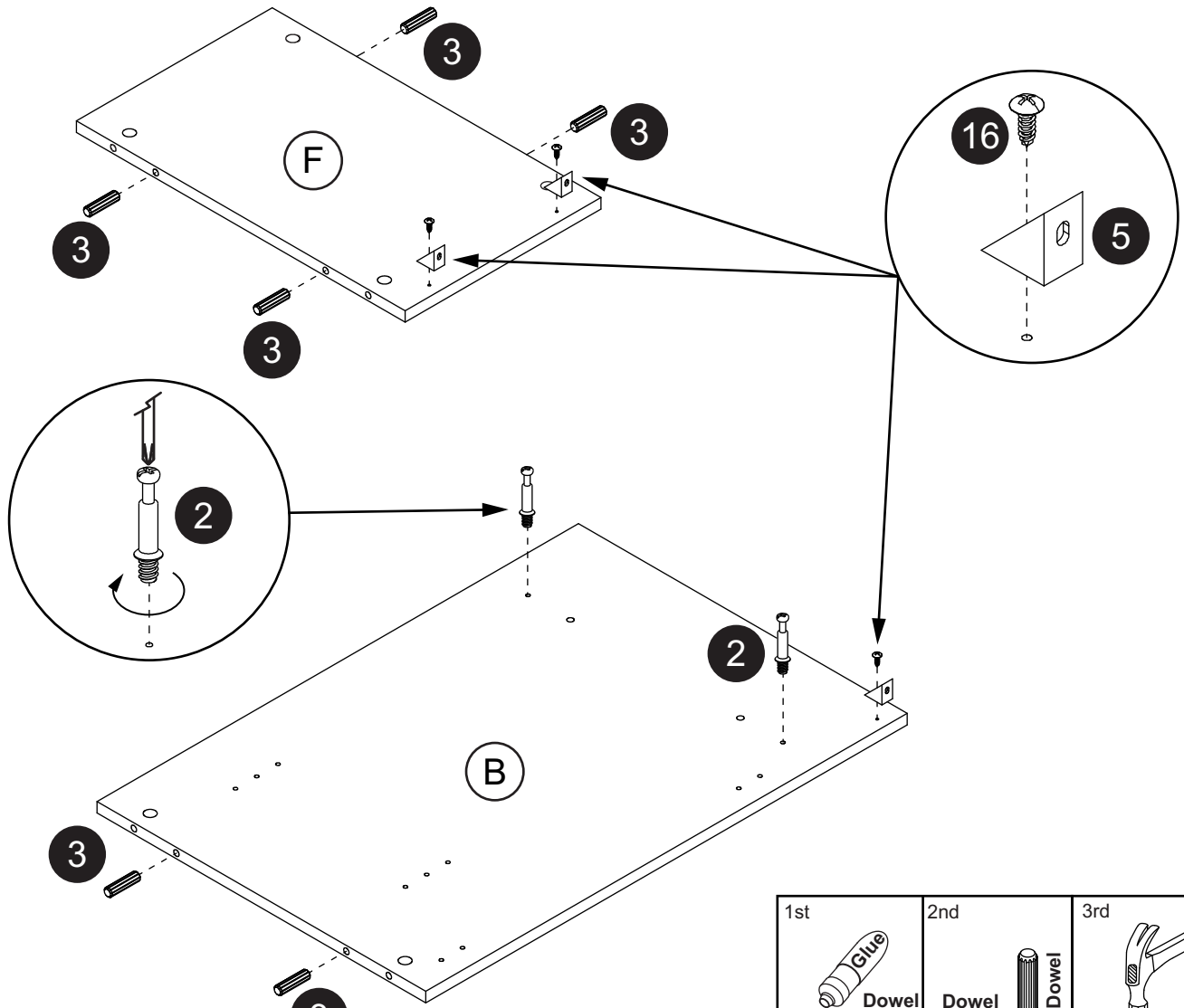
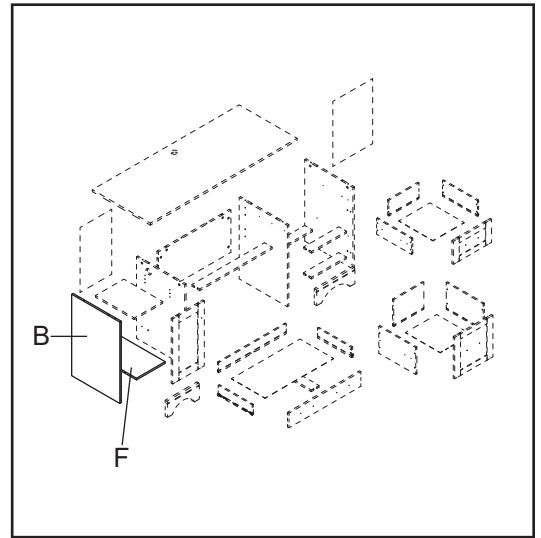

16  x 3

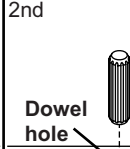
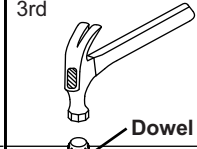
24 

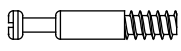

1st	2nd	3rd
 Dowel hole	 Dowel hole Dowel	 Dowel

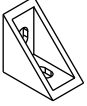
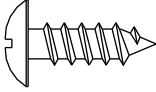
# 2

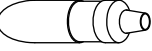
- 2**  x 5
- 3**  x 2
- 5**  x 1
- 16**  x 1
- 15**  x 3
- 25a**  x 1
- 24** 

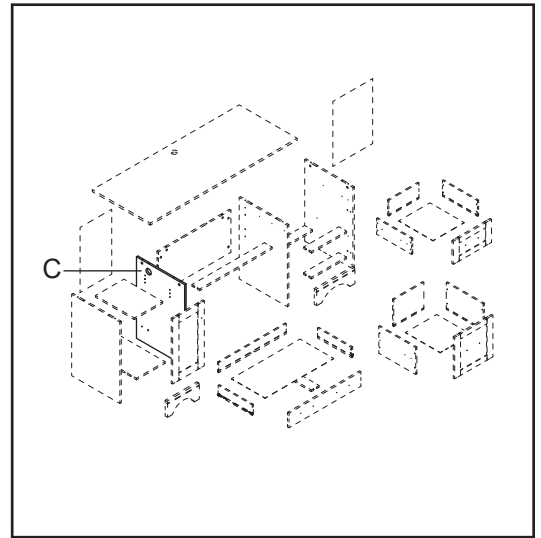

Roller end  
Extrémité à roulette  
Extremo con rodillo

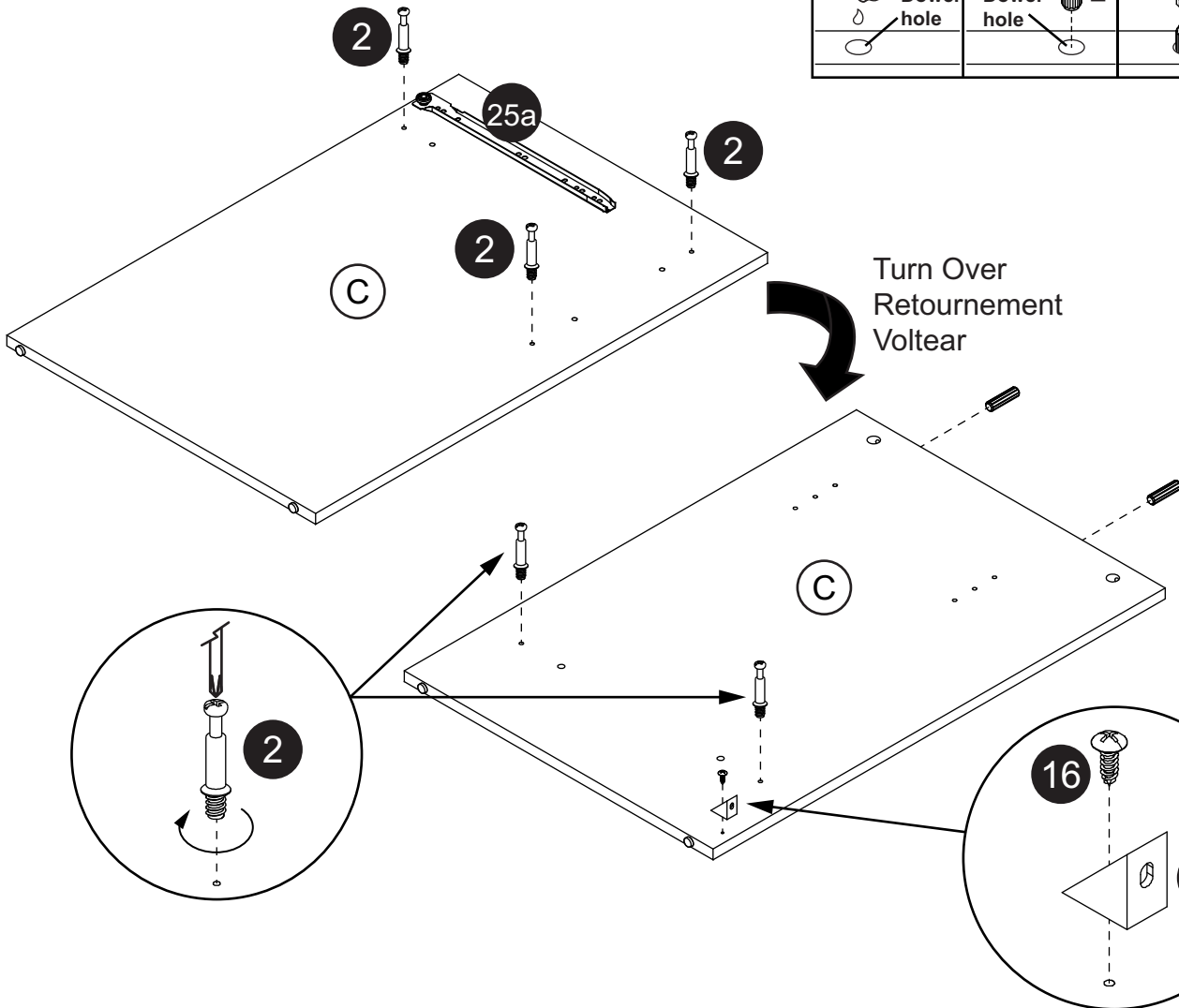
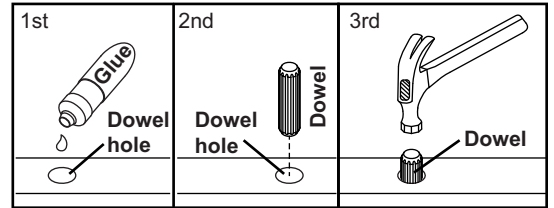
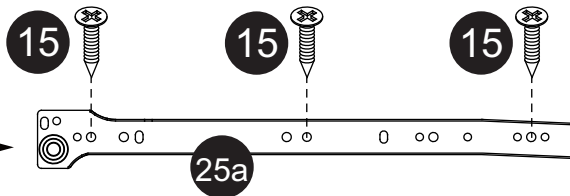

# 3

1



x 4

24

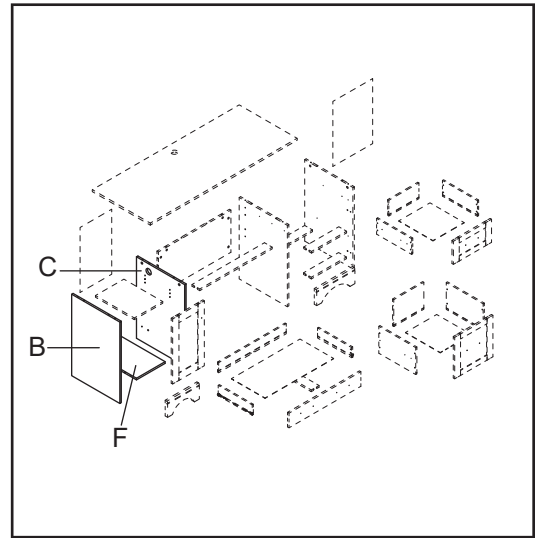
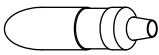

Finished edge  
Bord fini  
Borde con acabado

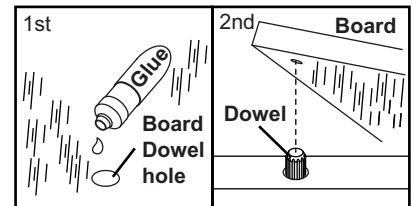
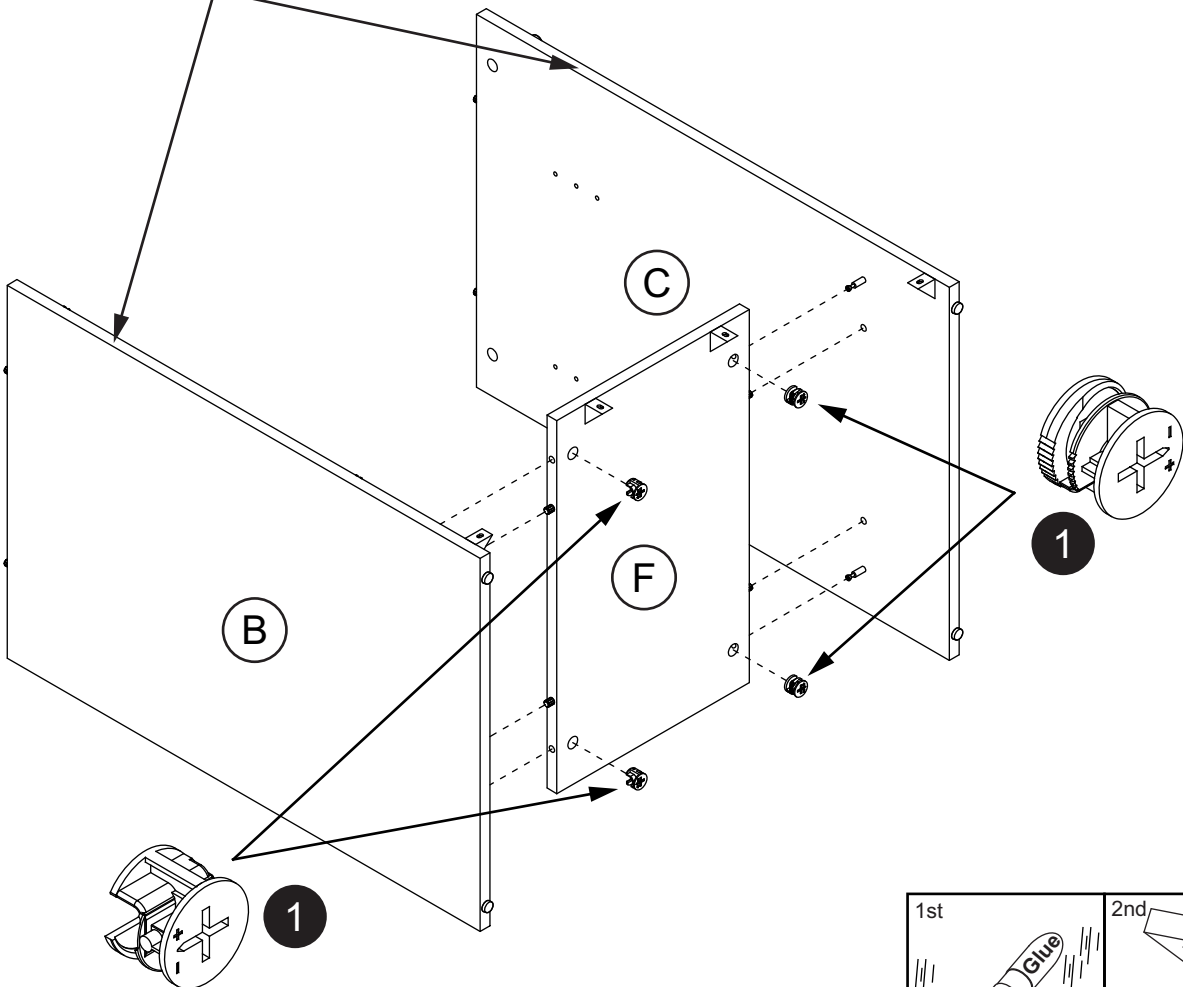

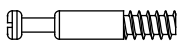

# 4

2  x 3

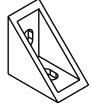

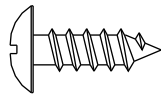
3  x 8

5  x 3

16  x 3

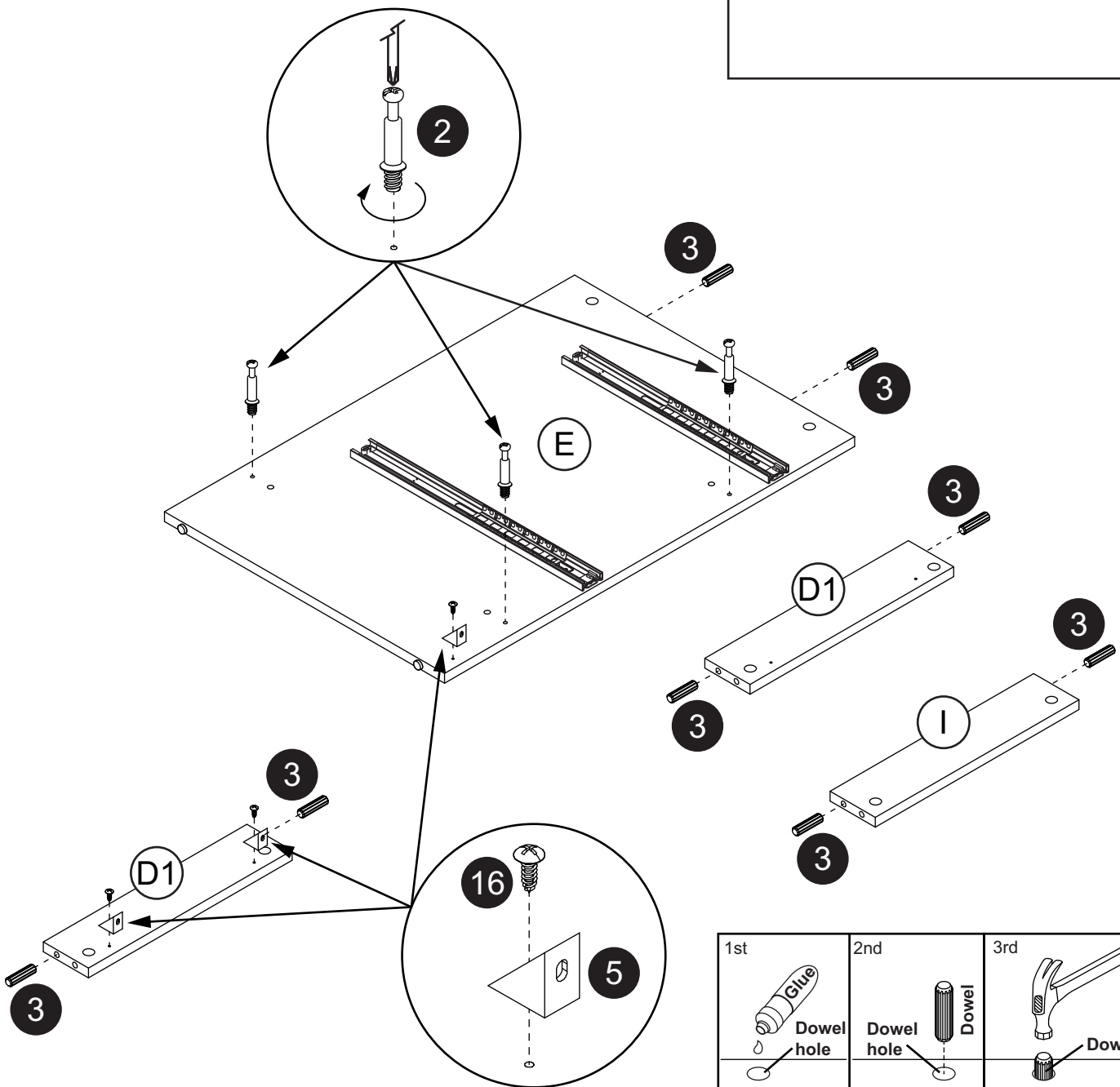
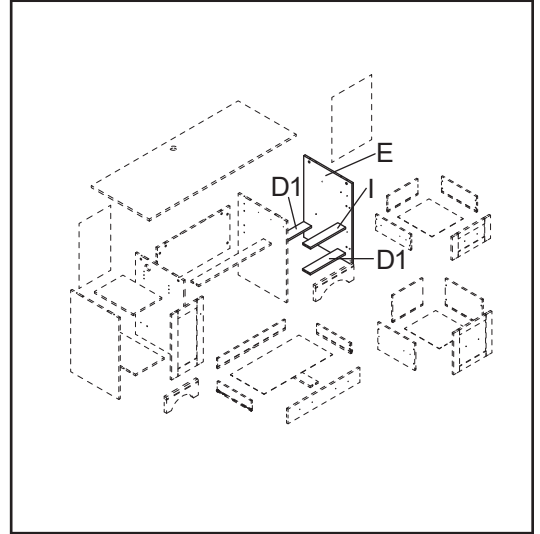
24 



1st	2nd	3rd
 Dowel hole	 Dowel hole Dowel	 Dowel

# 5

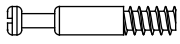
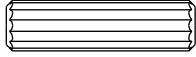
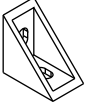
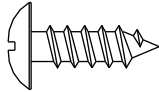
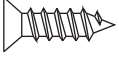
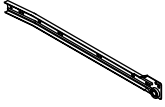
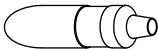
- 2  x 6
- 3  x 2
- 5  x 1
- 16  x 1
- 15  x 3
- 25c  x 1
- 24 

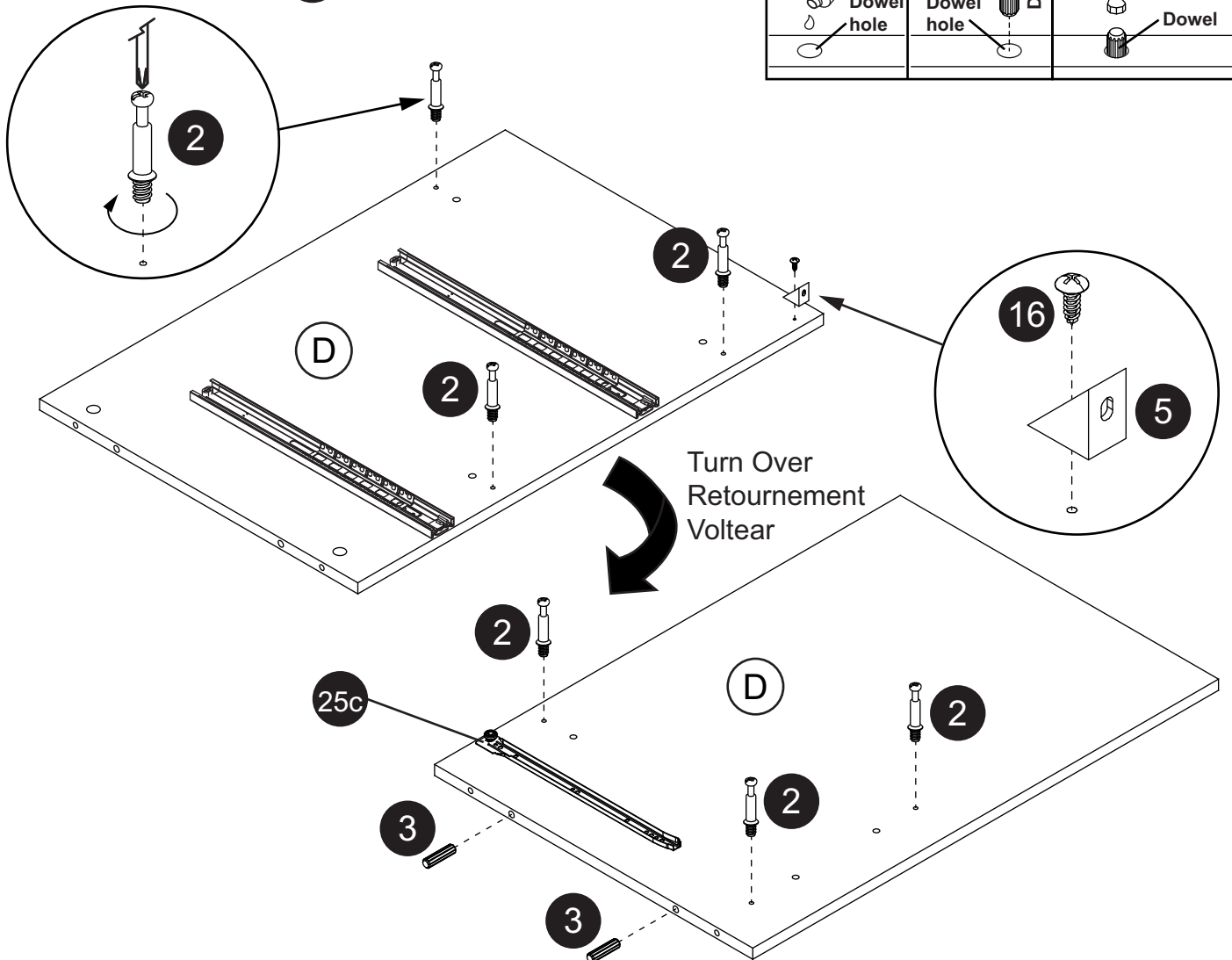
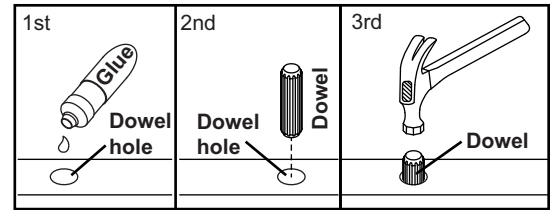
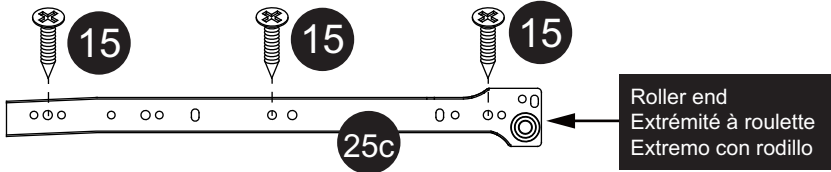
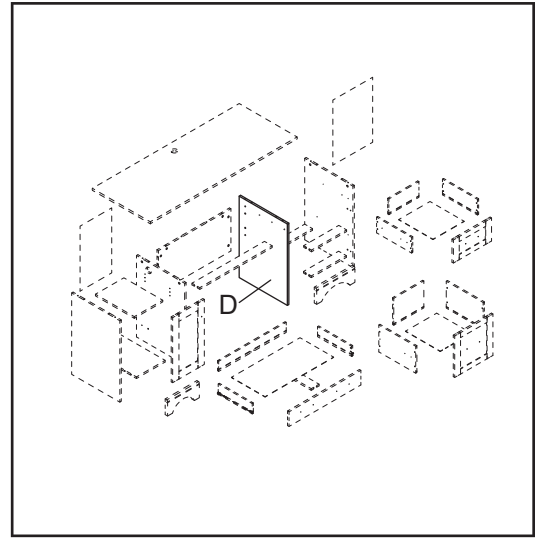

# 6

1



x 6

24

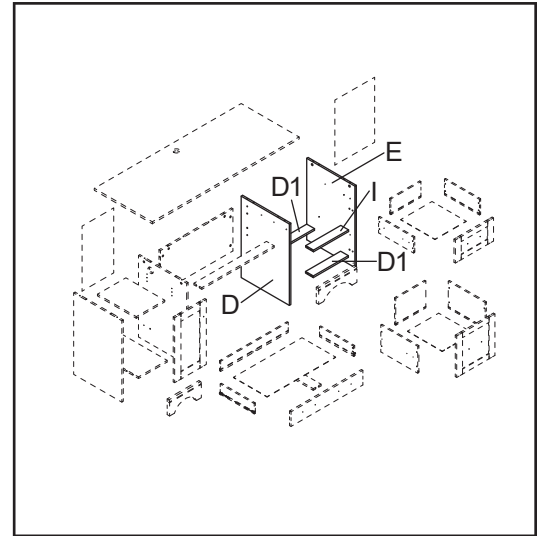

Finished edge  
Bord fini  
Borde con acabado

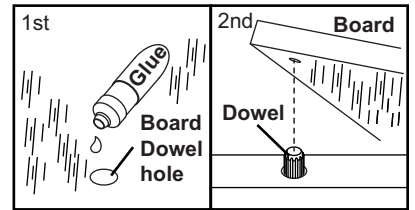
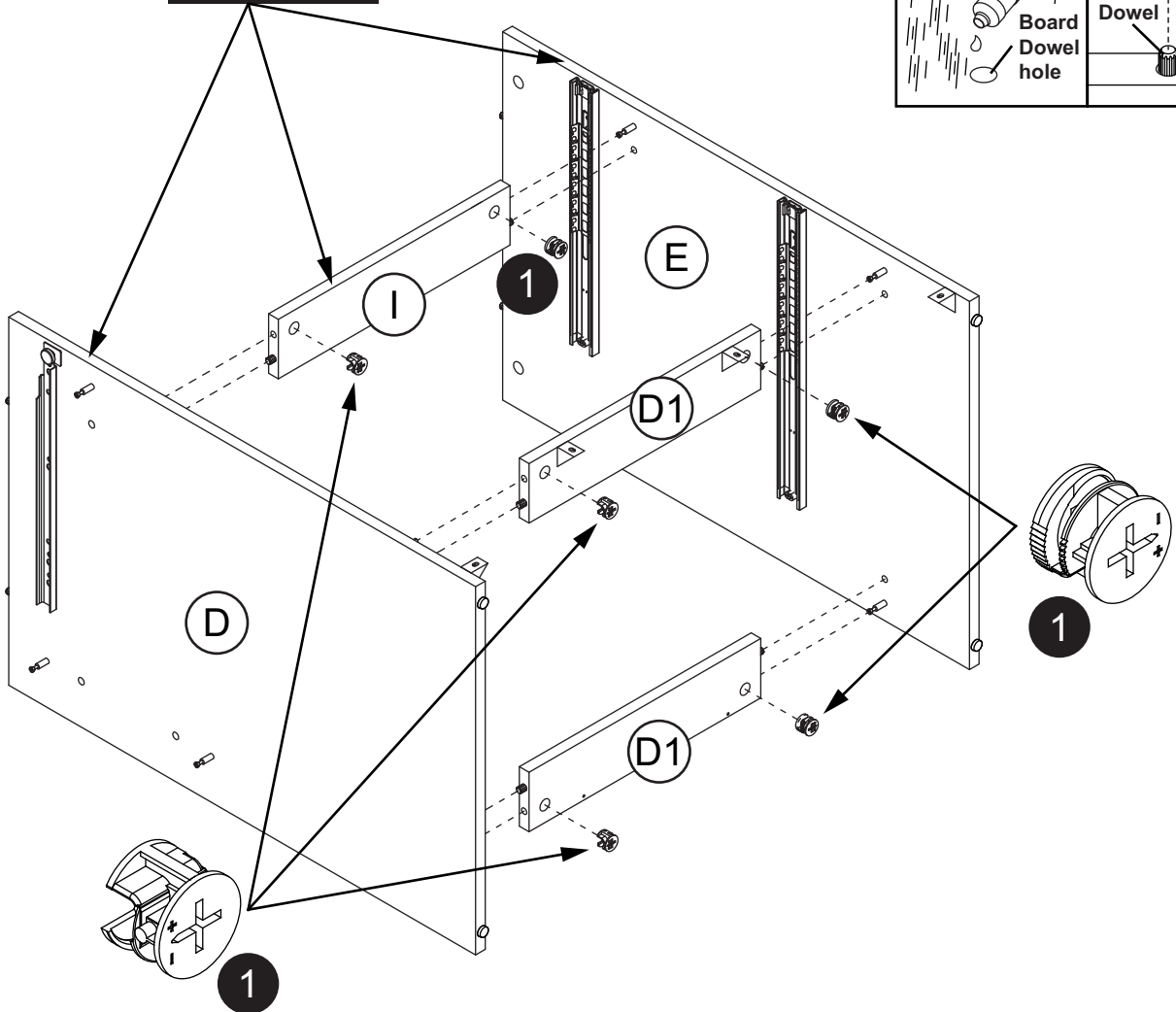

# 7

16

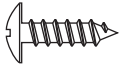

x 8

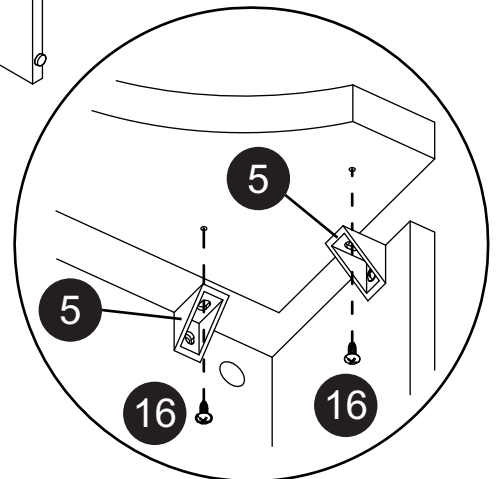
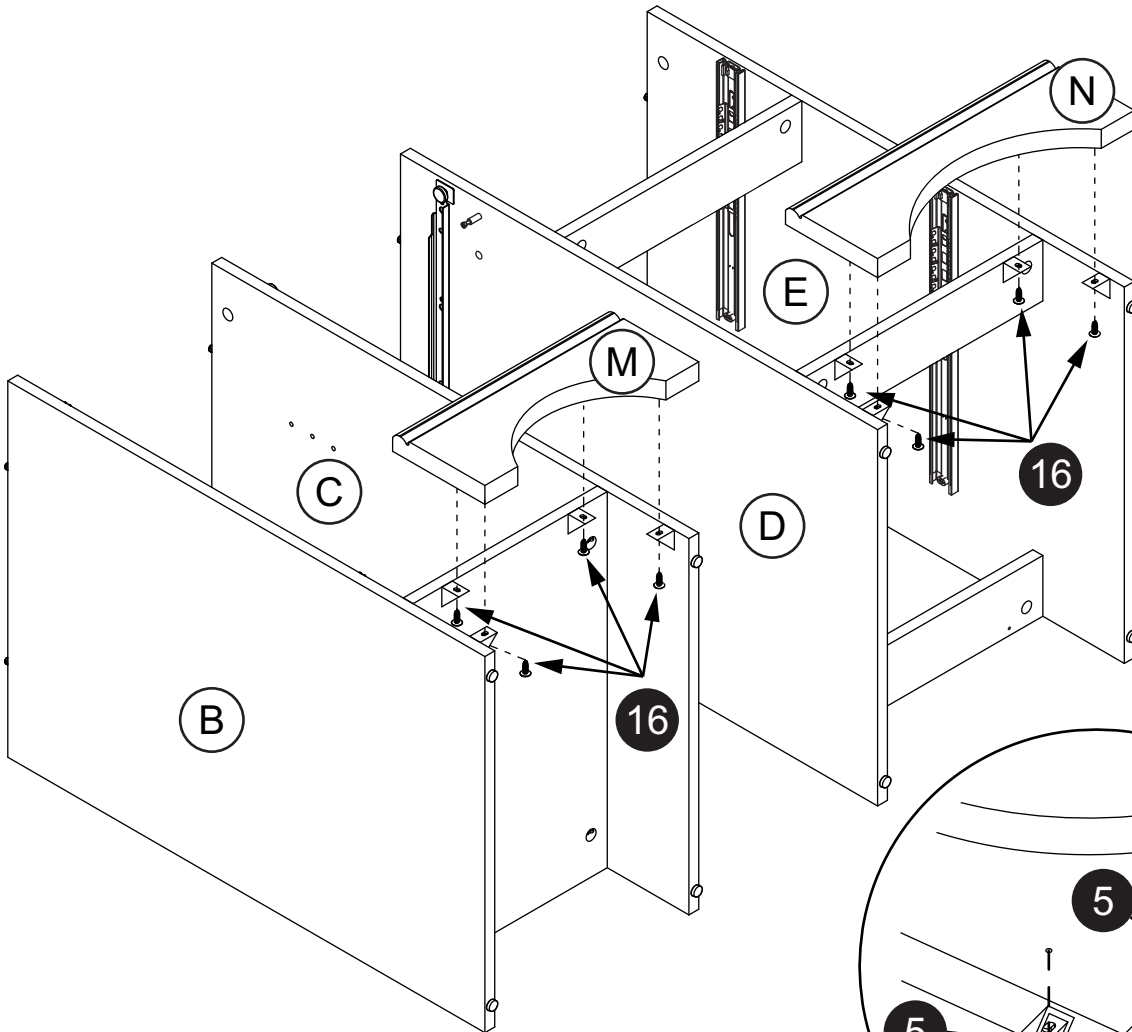
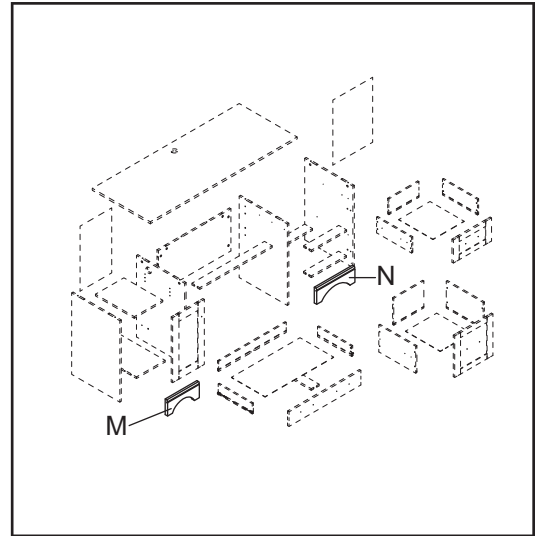



12

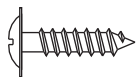

x 22

**Warning:** Two adults are recommended for this step.

**Avertissement:** Deux adultes sont recommandés pour cette étape.

**Aviso:** Se recomiendan dos adultos para este paso.

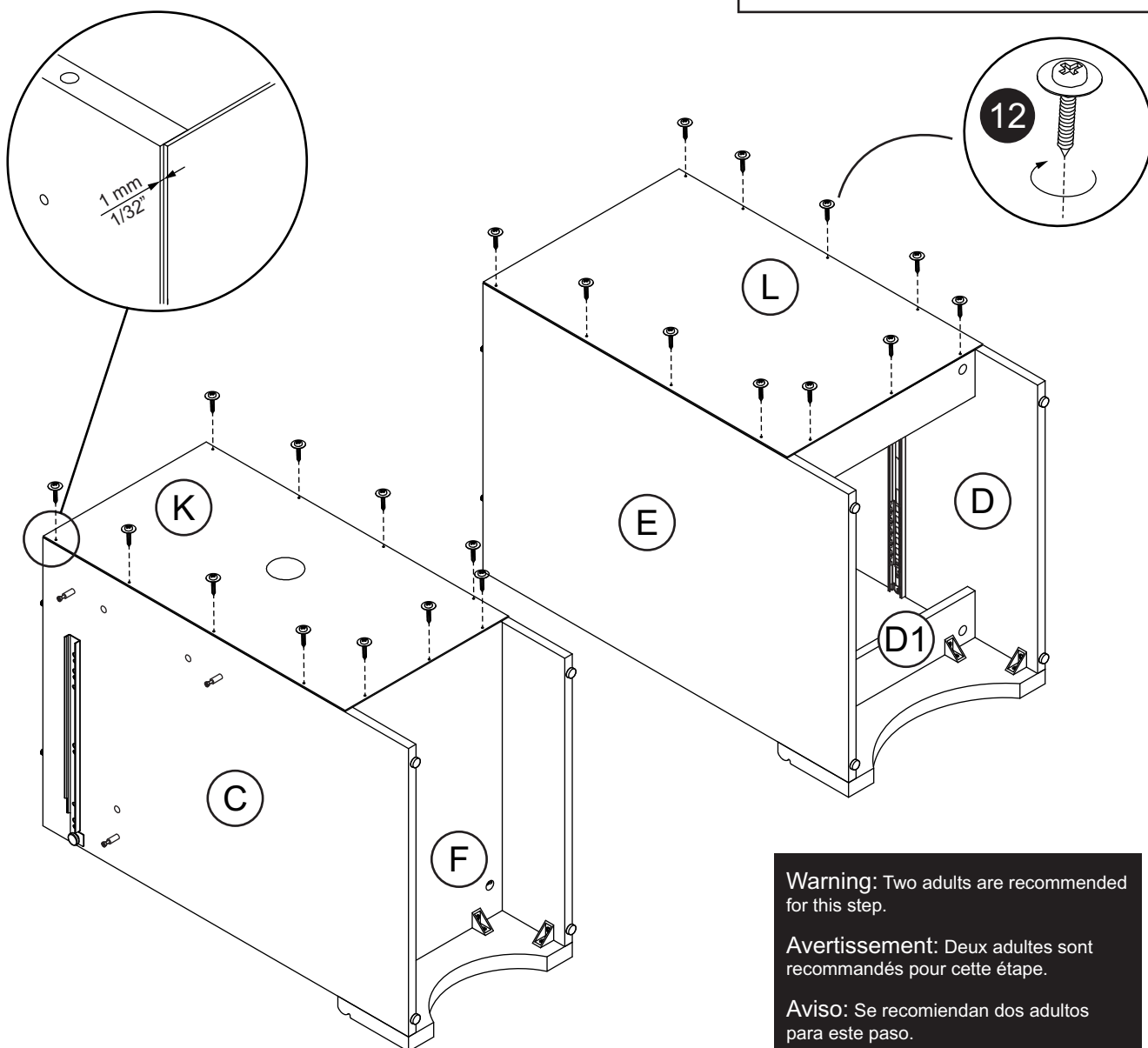
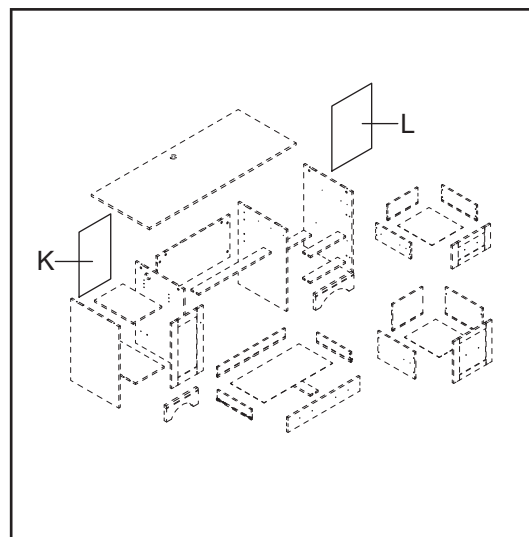

**Warning:** Two adults are recommended for this step.

**Avertissement:** Deux adultes sont recommandés pour cette étape.

**Aviso:** Se recomiendan dos adultos para este paso.

# 9

1



x 6

3

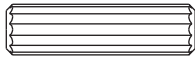

x 8

24

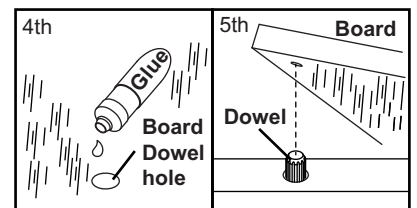
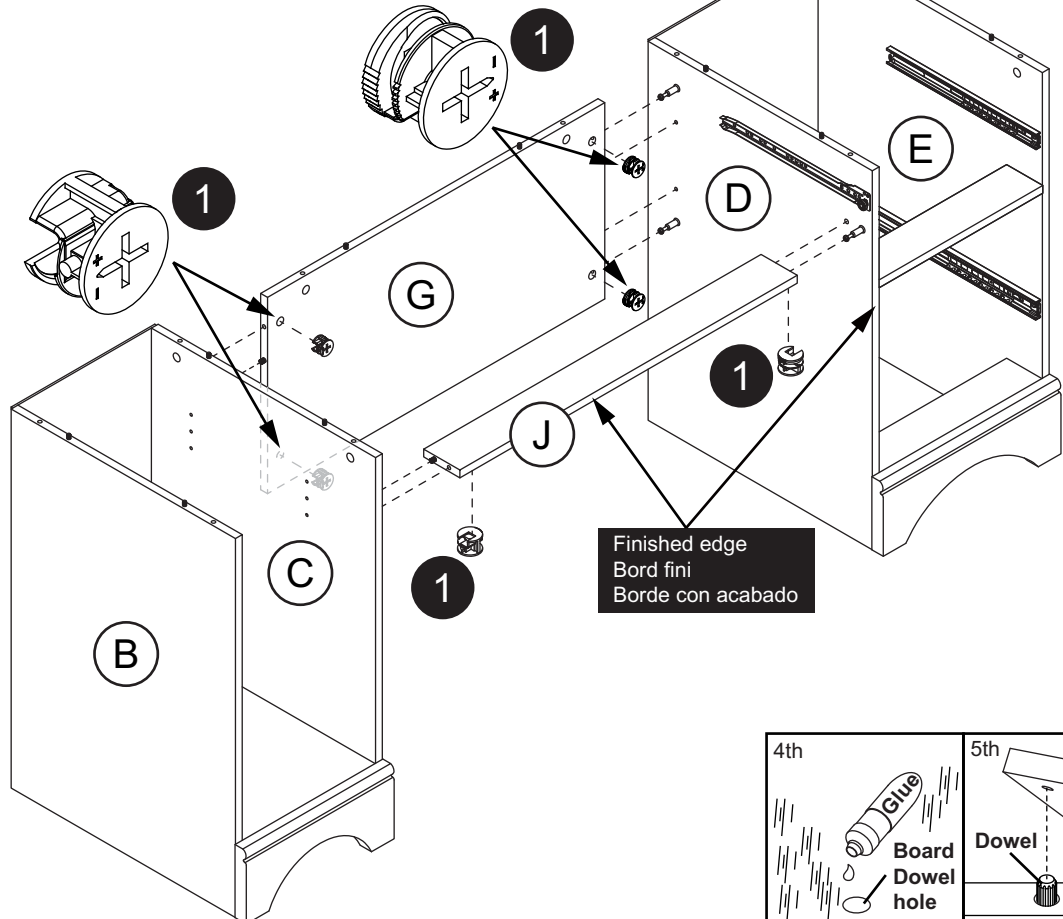
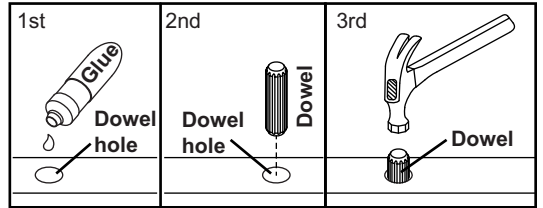
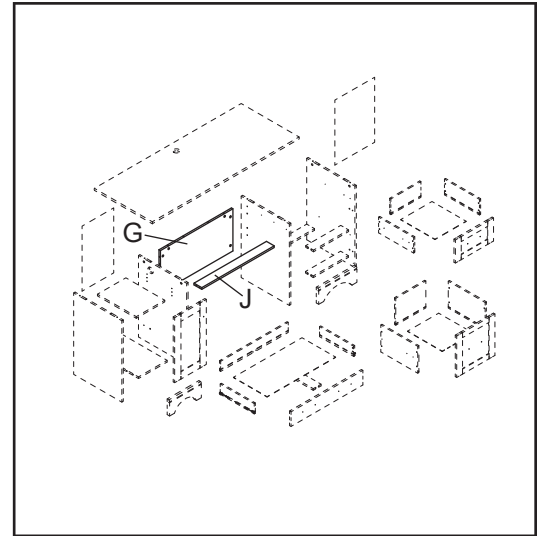
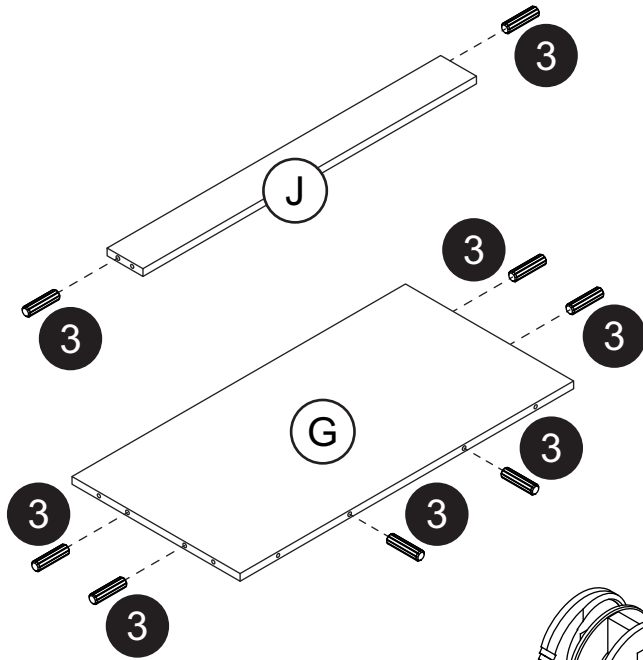
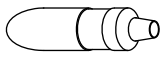

# 10

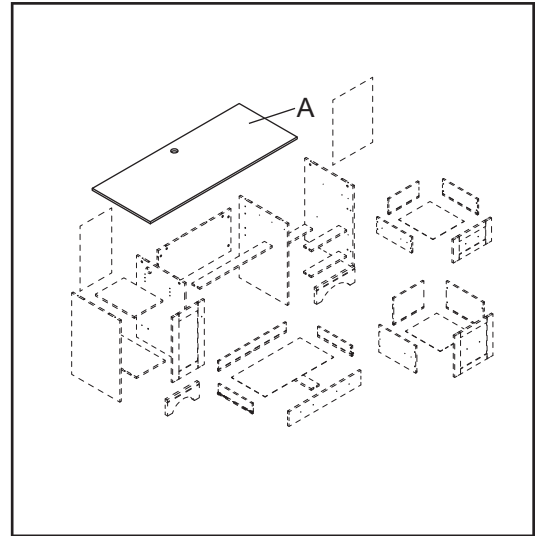
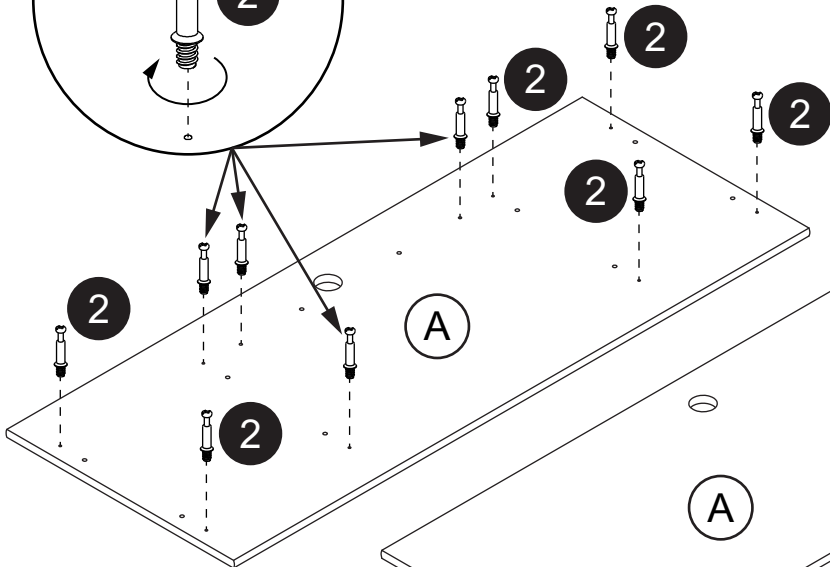
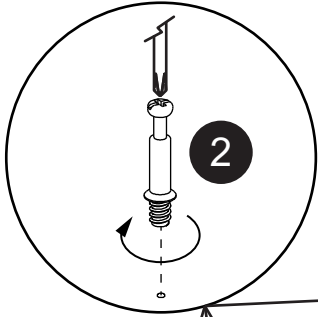
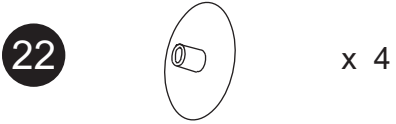
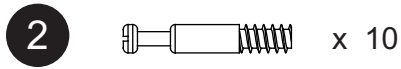
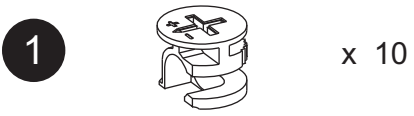

**Warning:** Two adults are recommended for this step.  
**Avertissement:** Deux adultes sont recommandés pour cette étape.  
**AVISO:** Se recomiendan dos adultos para este paso.

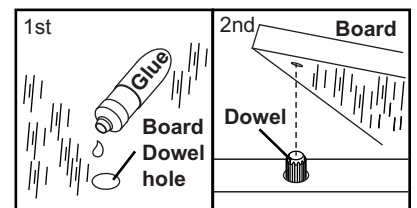
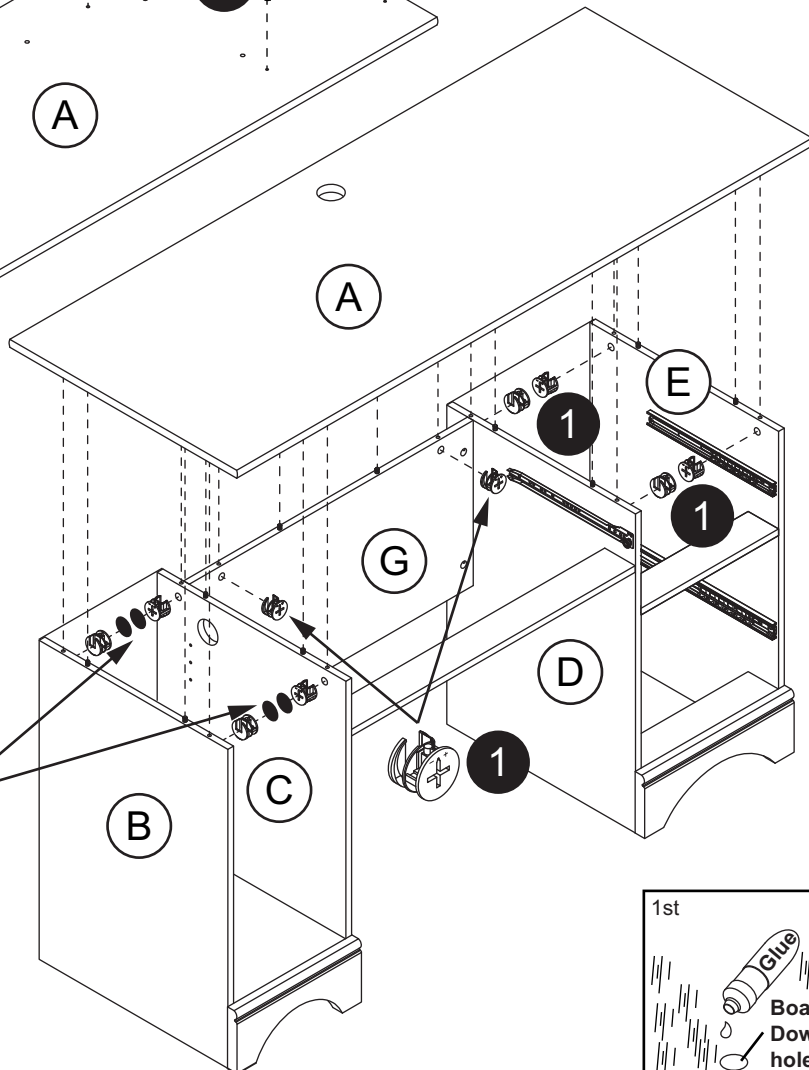
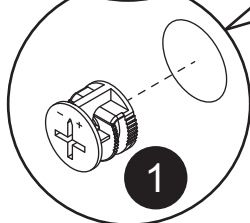
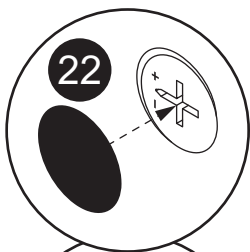

# 11

10



x 1

11

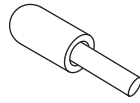

x 4

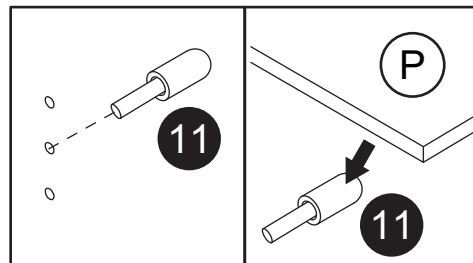
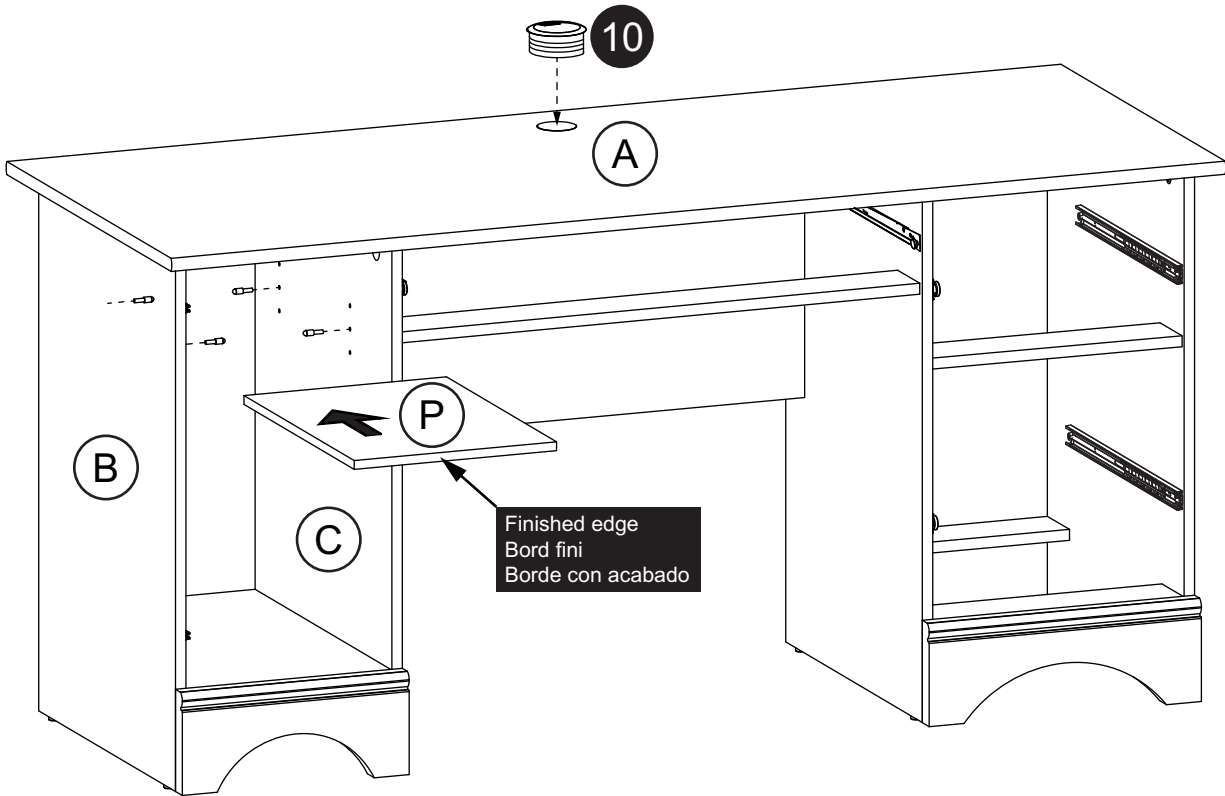
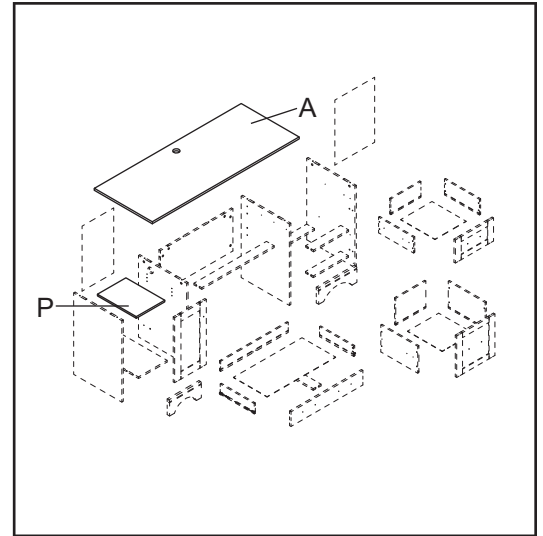

# 12

4  x 1

14  x 2

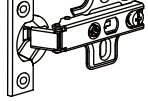
9  x 2

15  x 4

23  x 1

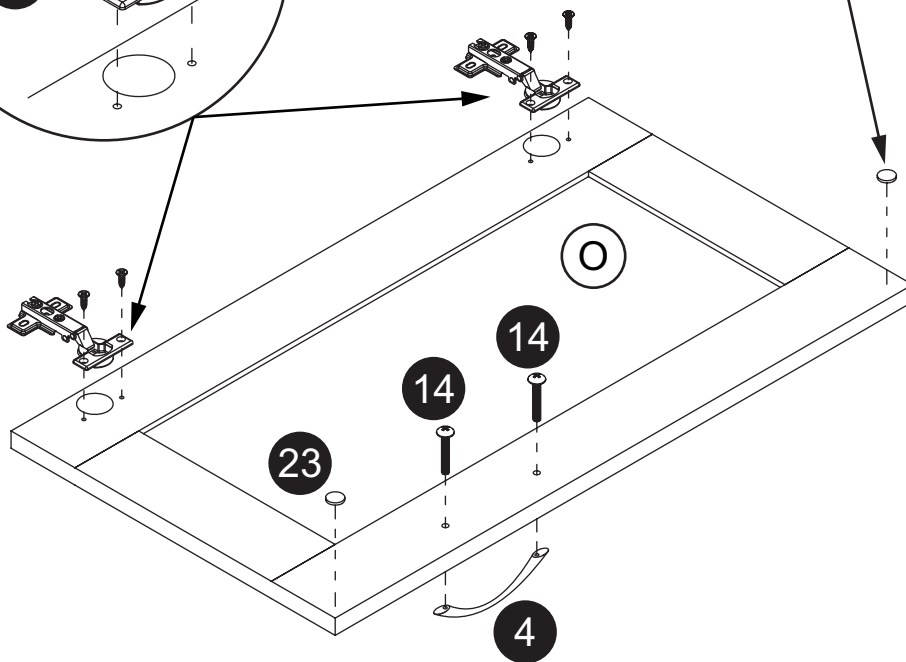
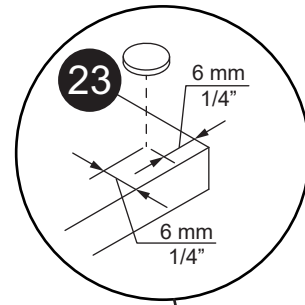
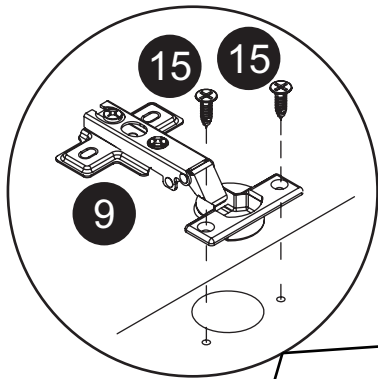
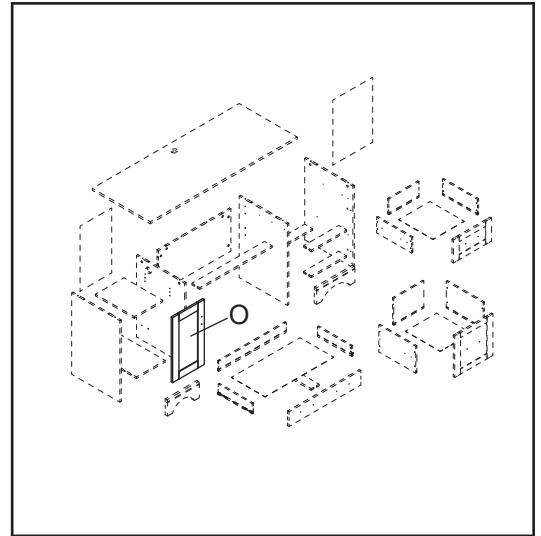

# 13





15

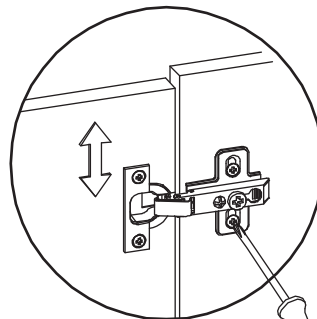
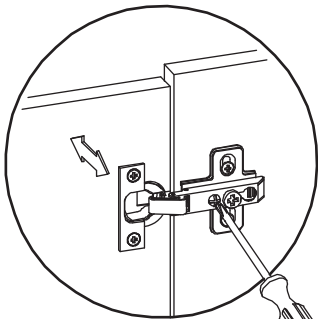
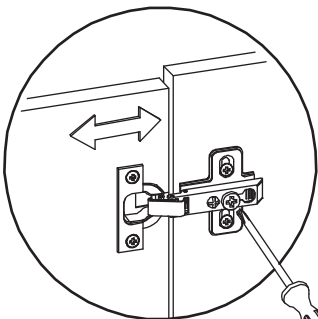
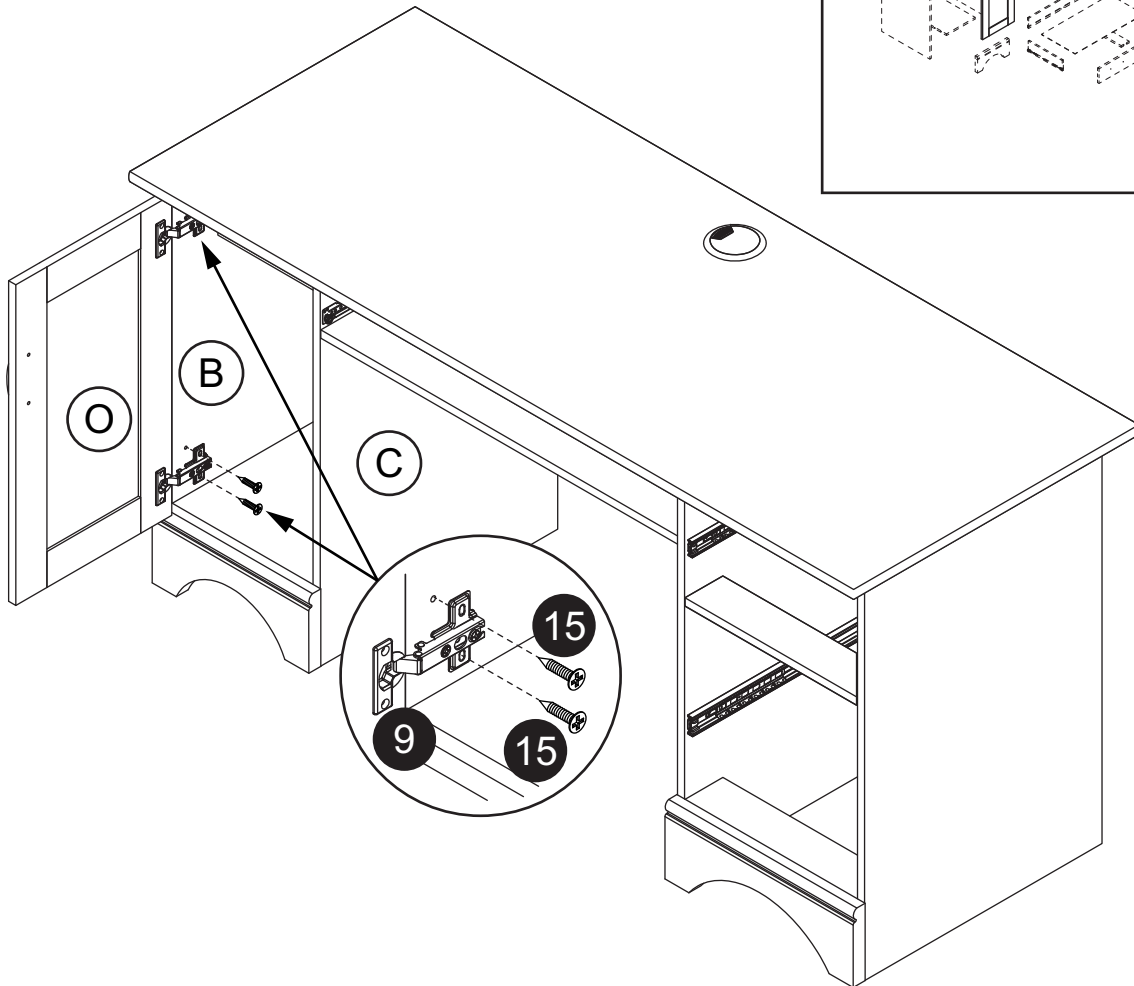
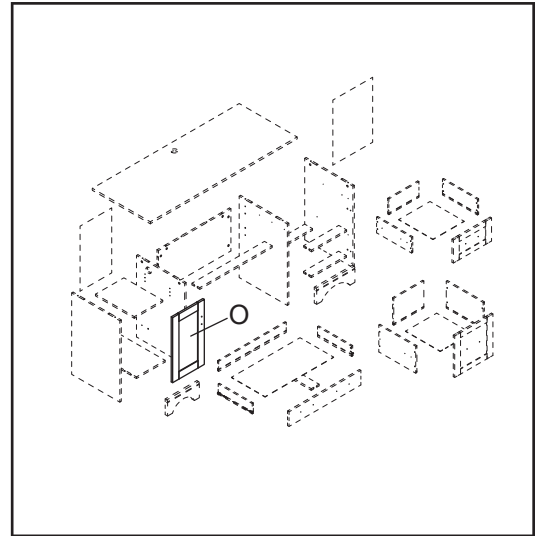

x 4

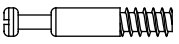

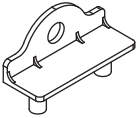
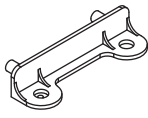
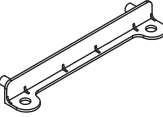
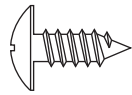
# 14

- 2

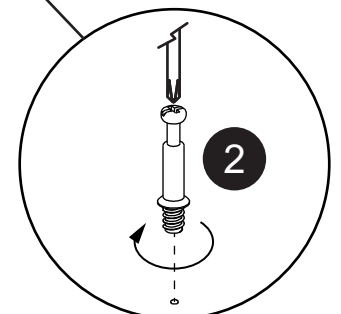
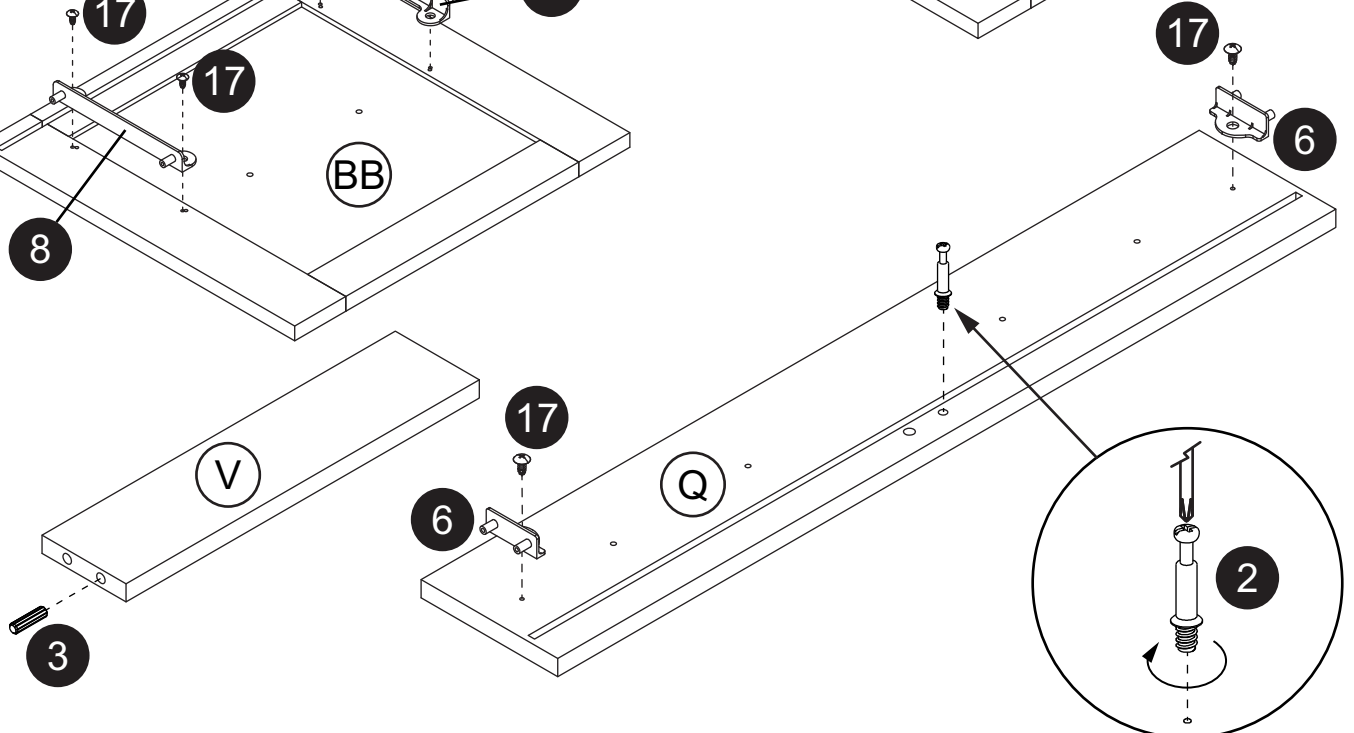
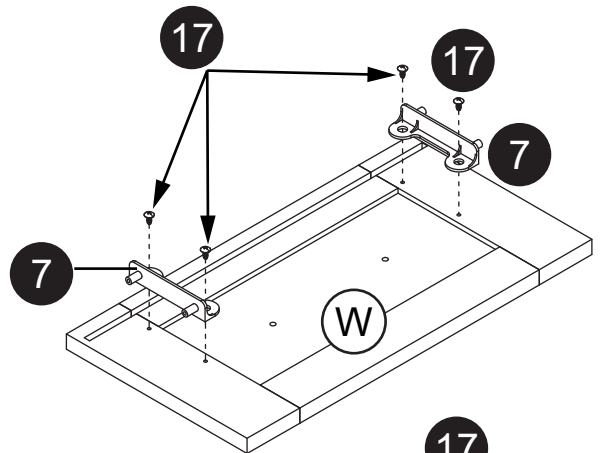
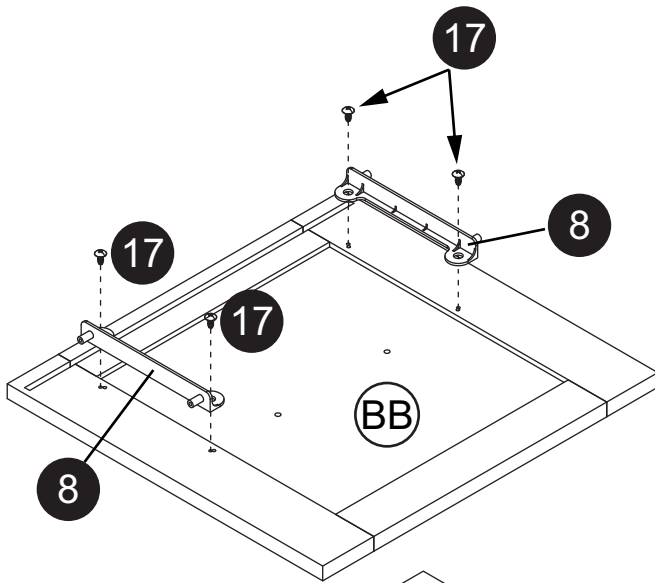
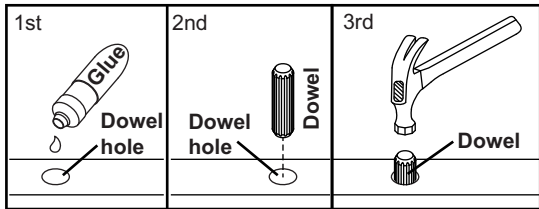
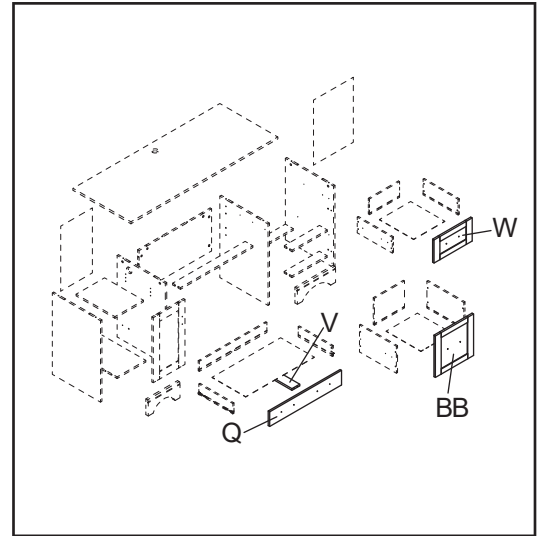
x 1
- 3

x 1
- 6

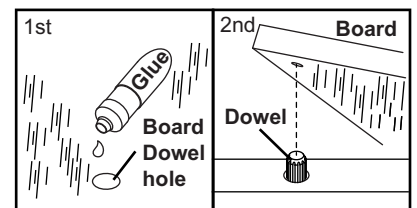
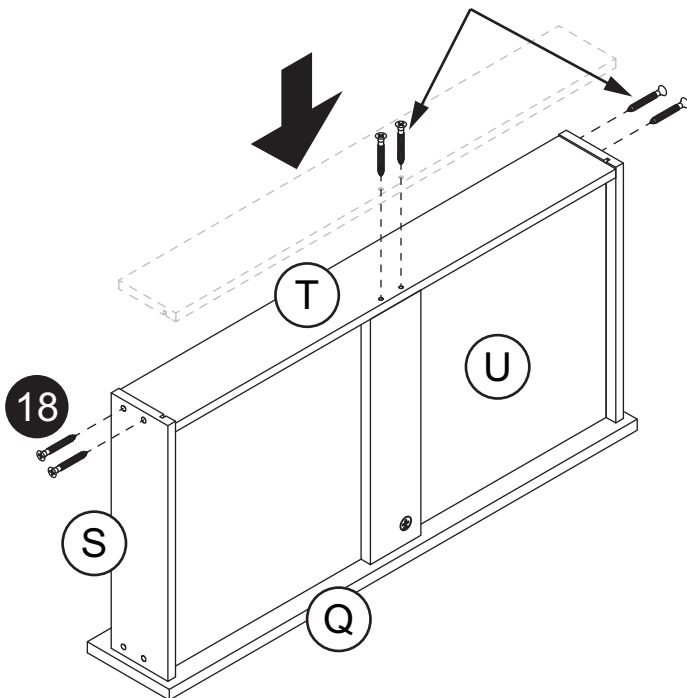
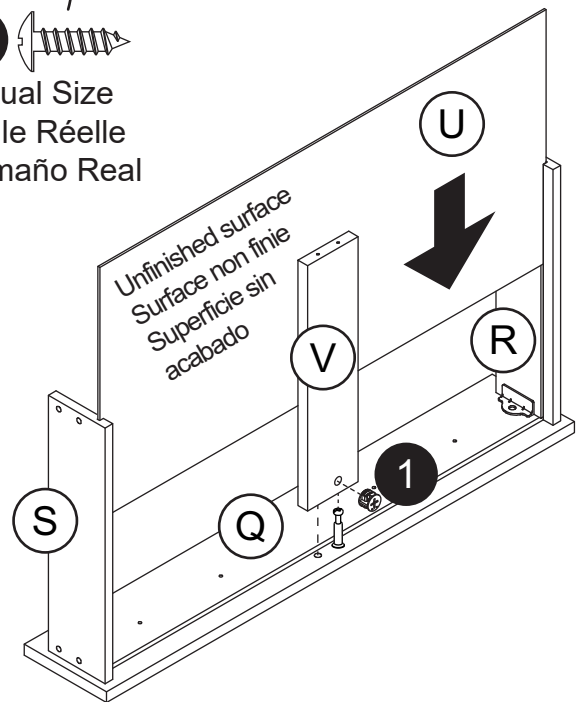
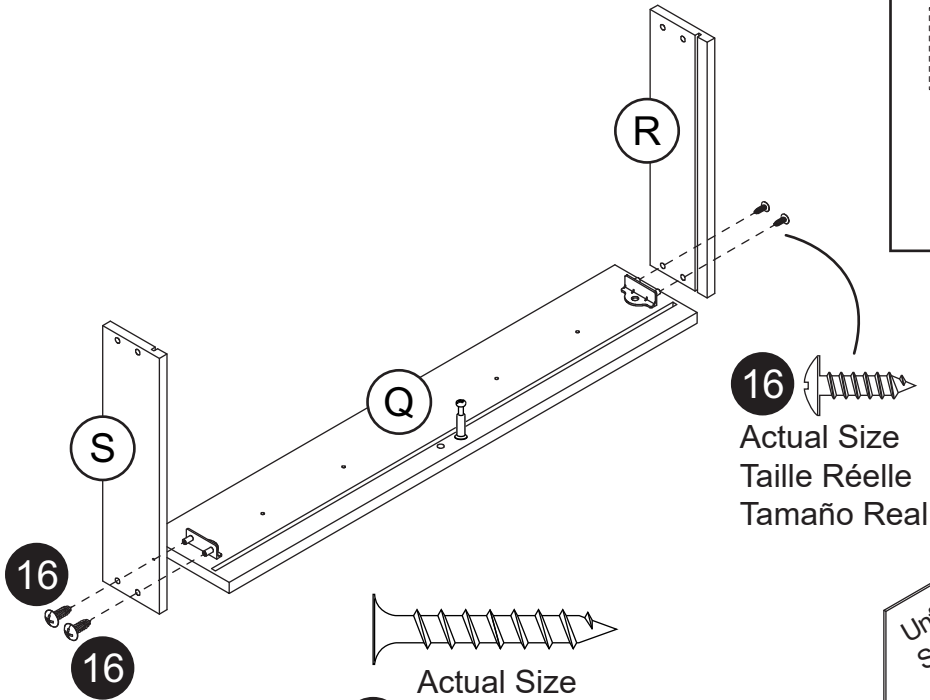
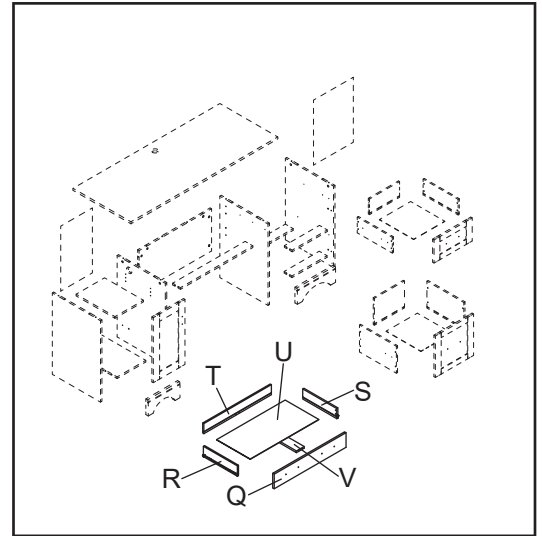
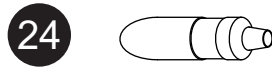
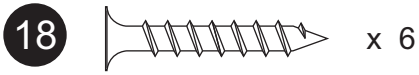
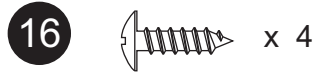
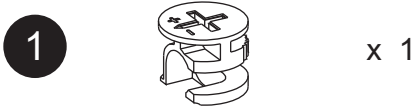
x 2
- 7

x 2
- 8

x 2
- 17

x 10
- 24



# 15



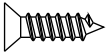

# 16

15  x 6

25b  x 1

25d  x 1

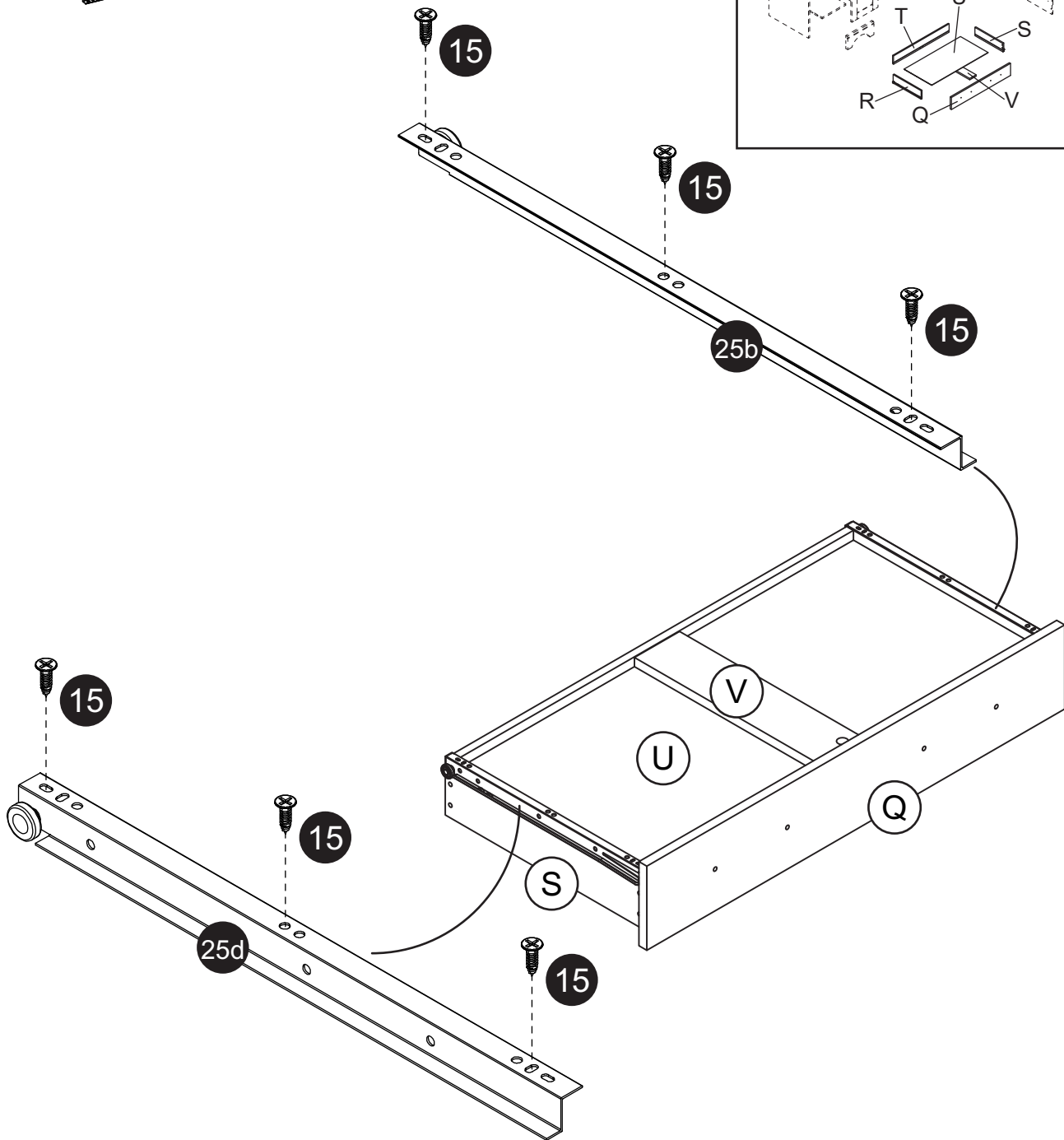
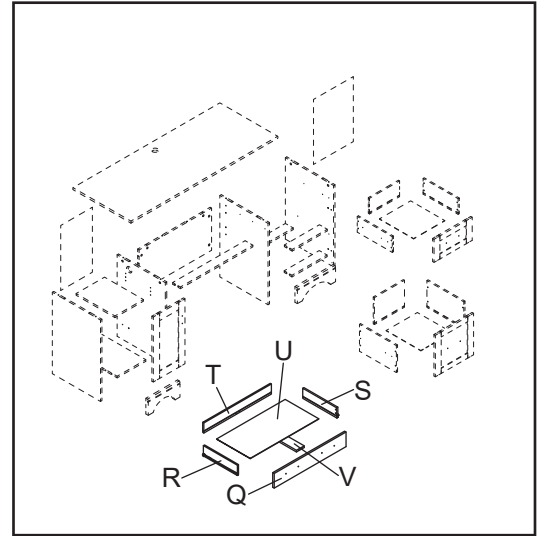

# 17

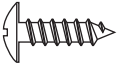
16  x 4

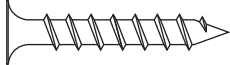
18  x 4

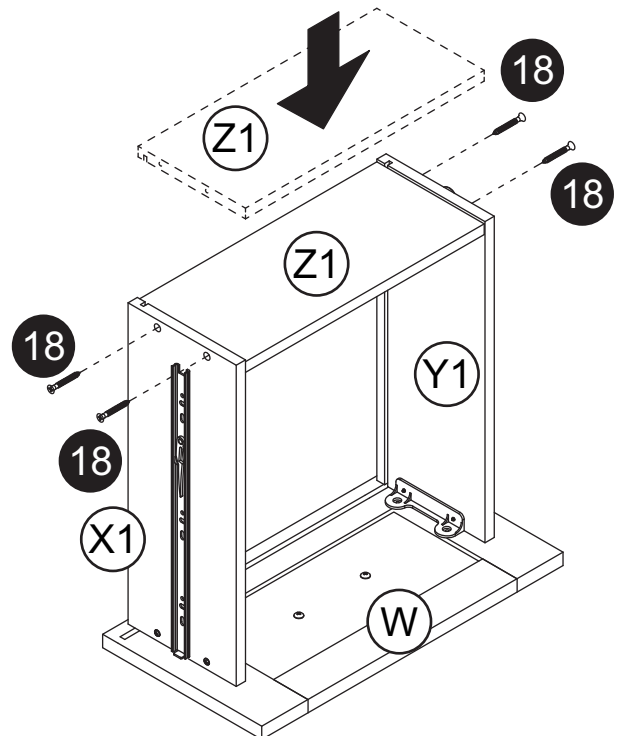
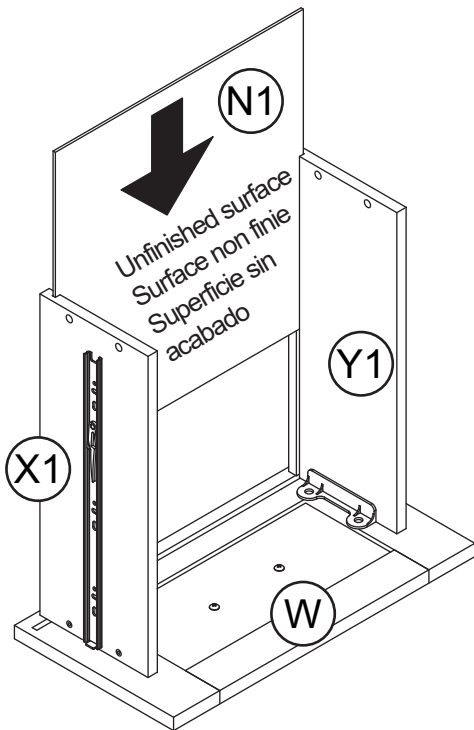
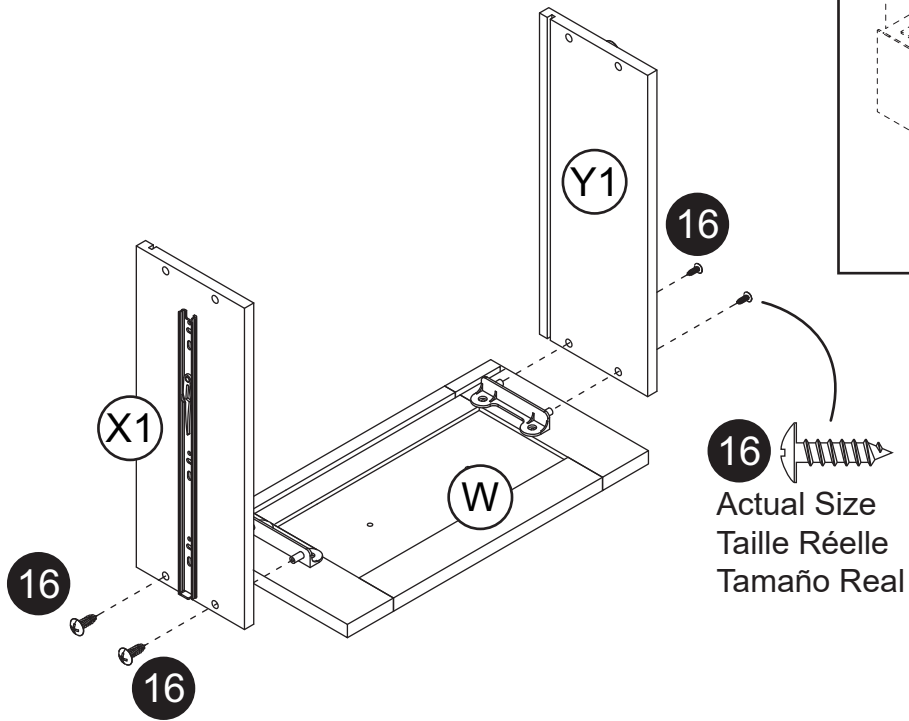
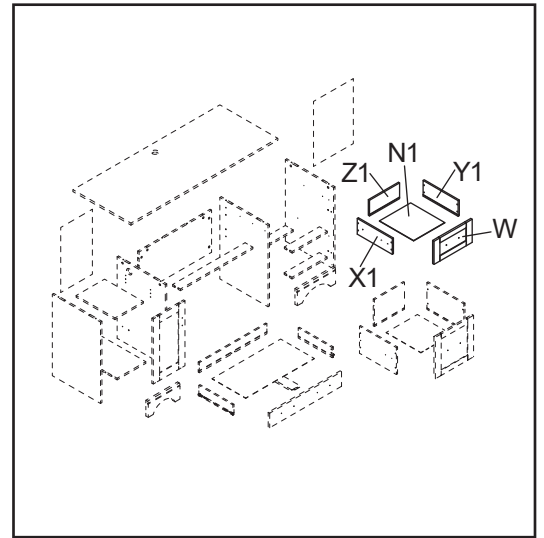

# 18

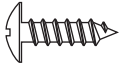
16  x 4

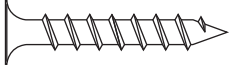
18  x 4

19  x 1

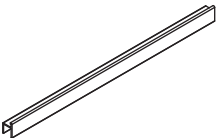
20  x 2

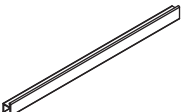
21  x 1

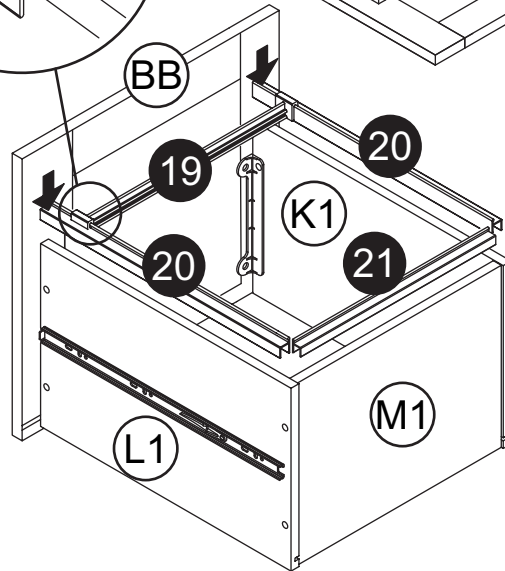
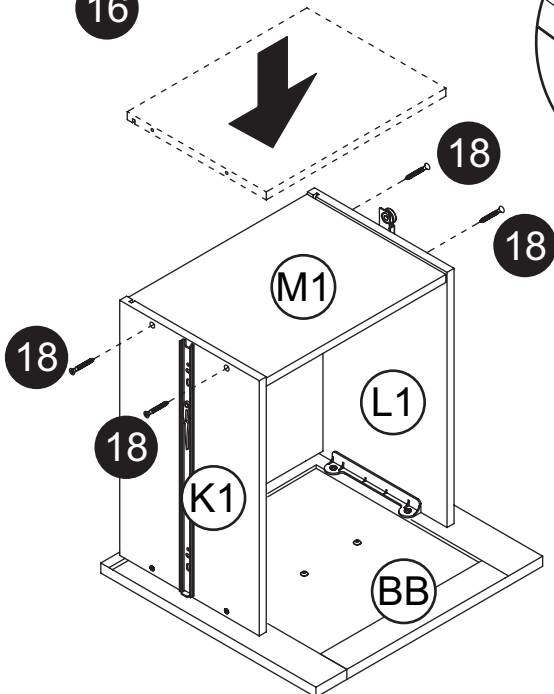
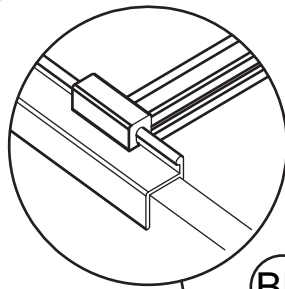
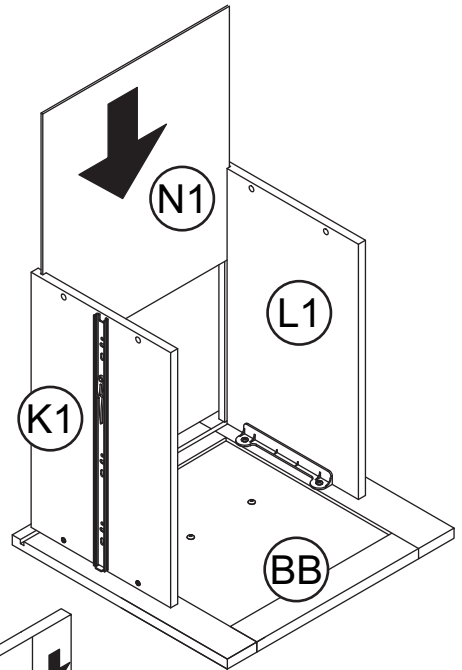
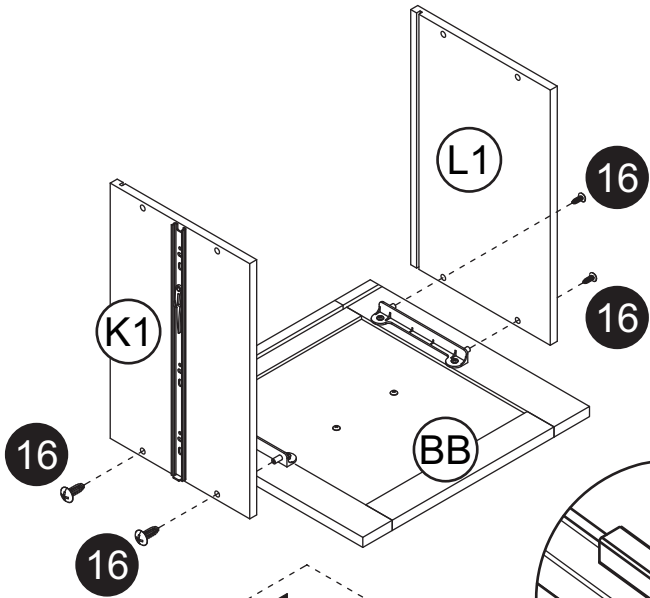
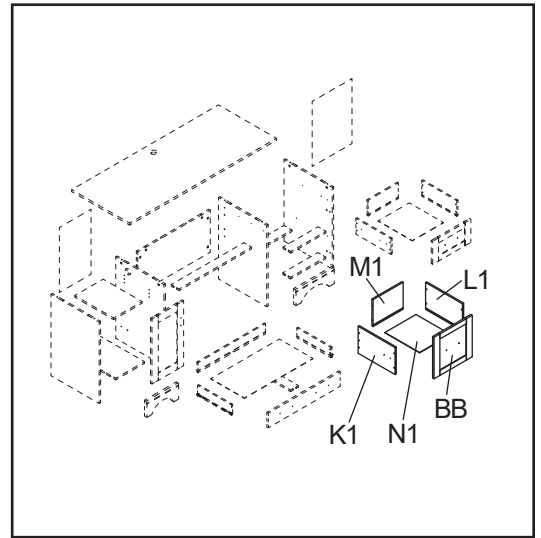

# 19

4  x 4

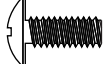
13  x 4

14  x 4

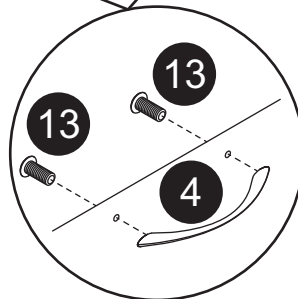
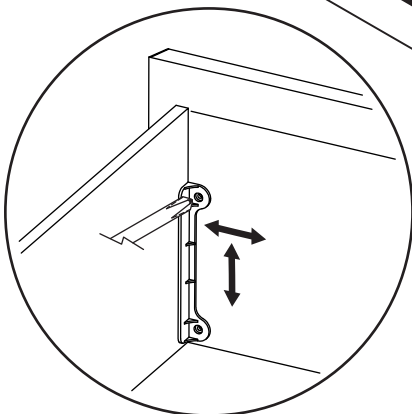
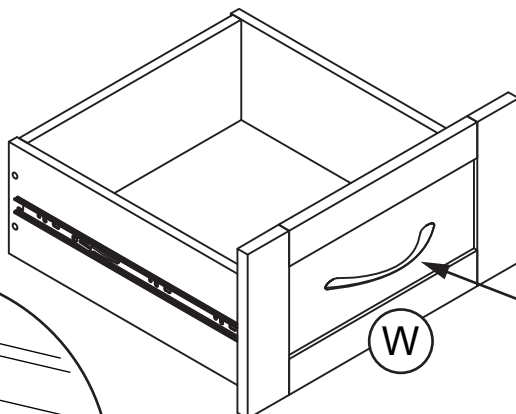
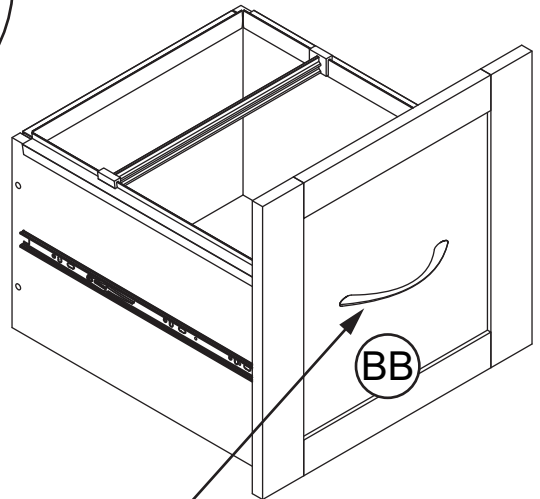
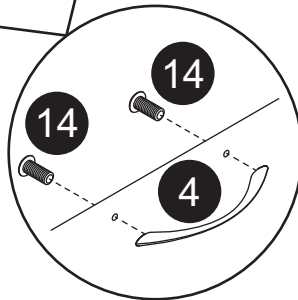
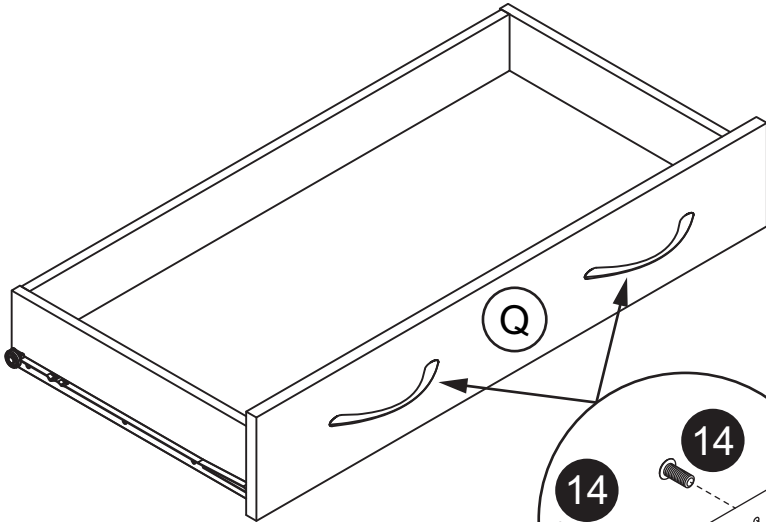
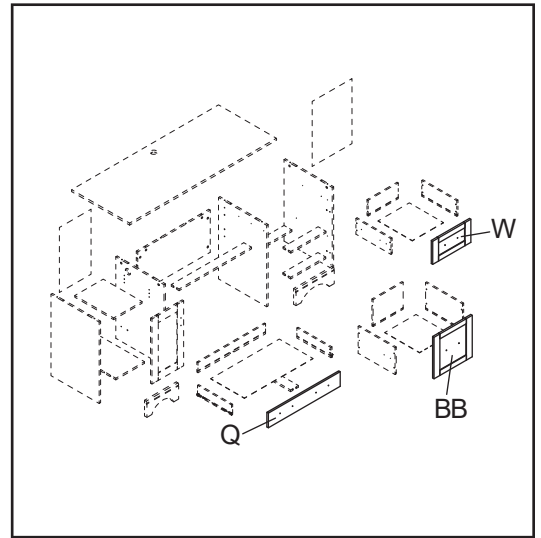

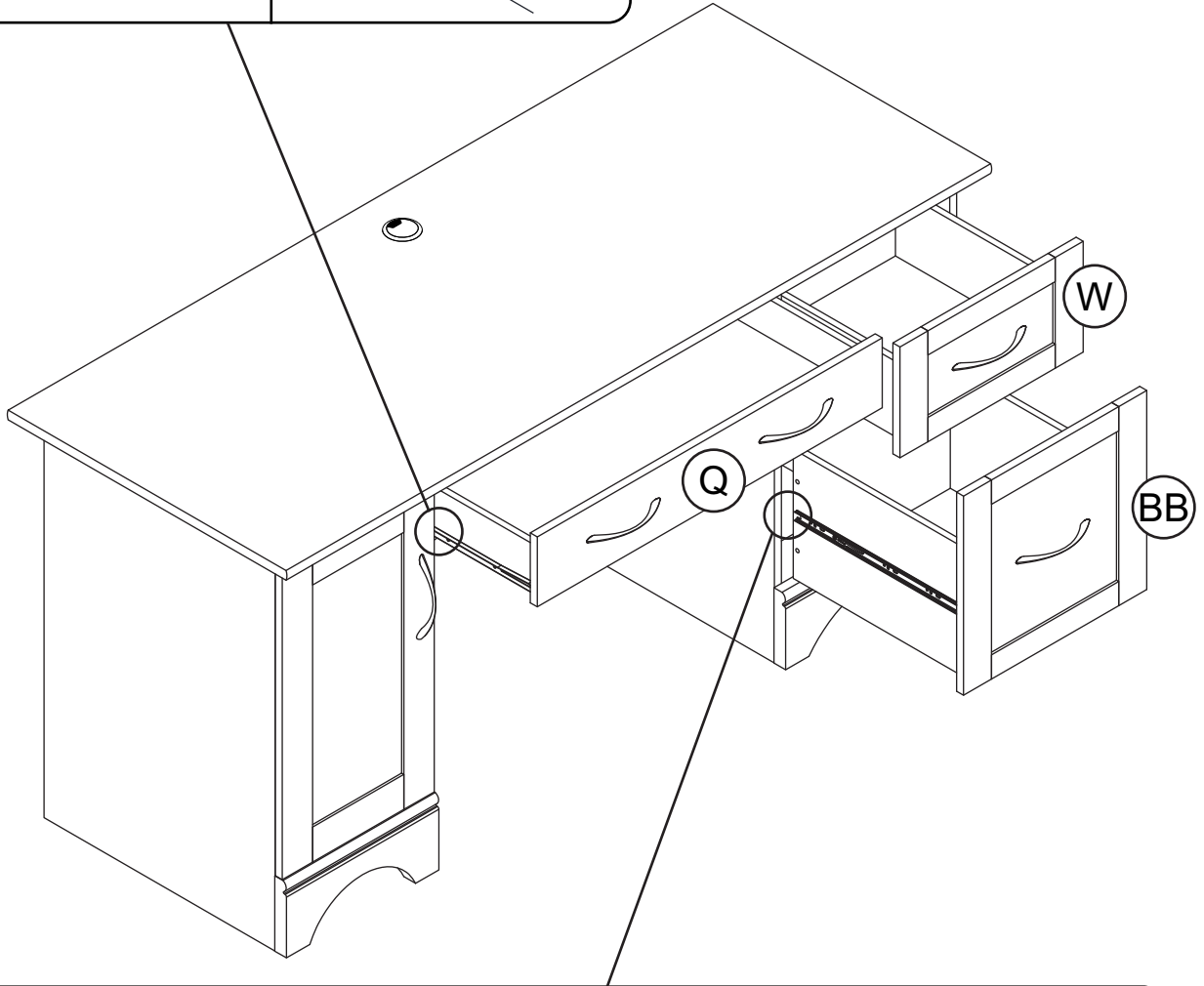
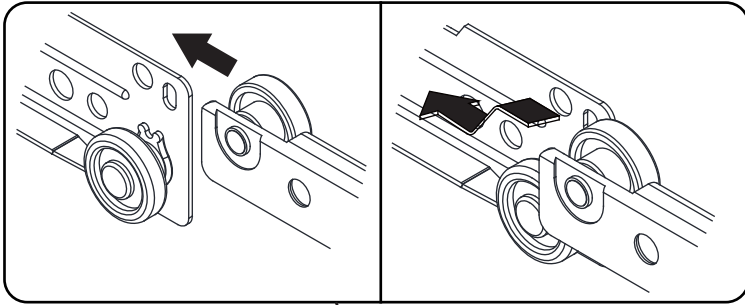

1

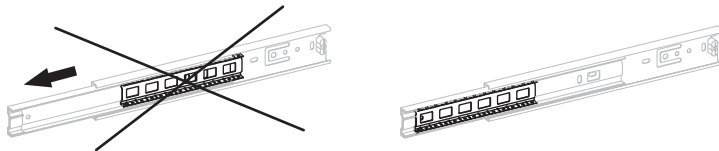

Pull the inner ball bearing slides on each side all the way out till it stops.  
(may be slightly greasy).

Tirez toujours le curseur à roulement à billes à l'intérieur vers l'extérieur  
jusqu'à ce qu'il s'arrête (peut être graissé).

Tire hacia fuera del deslizador interno de rodamiento de bolas hasta que  
se detenga (posiblemente un poco grasiento).

2

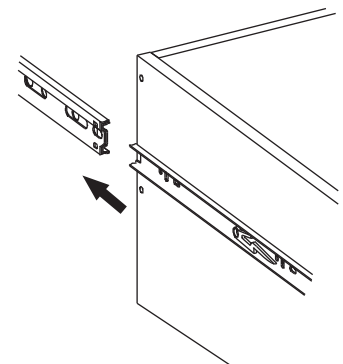

**To Remove Drawer, If Needed**  
**Pour retirer le tiroir, si nécessaire**  
**Para retirar el cajón, si es necesario**

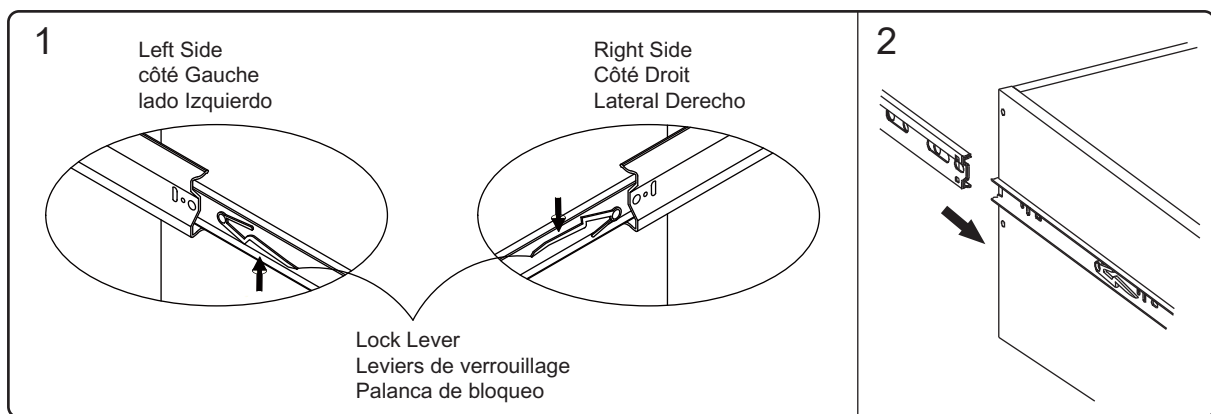
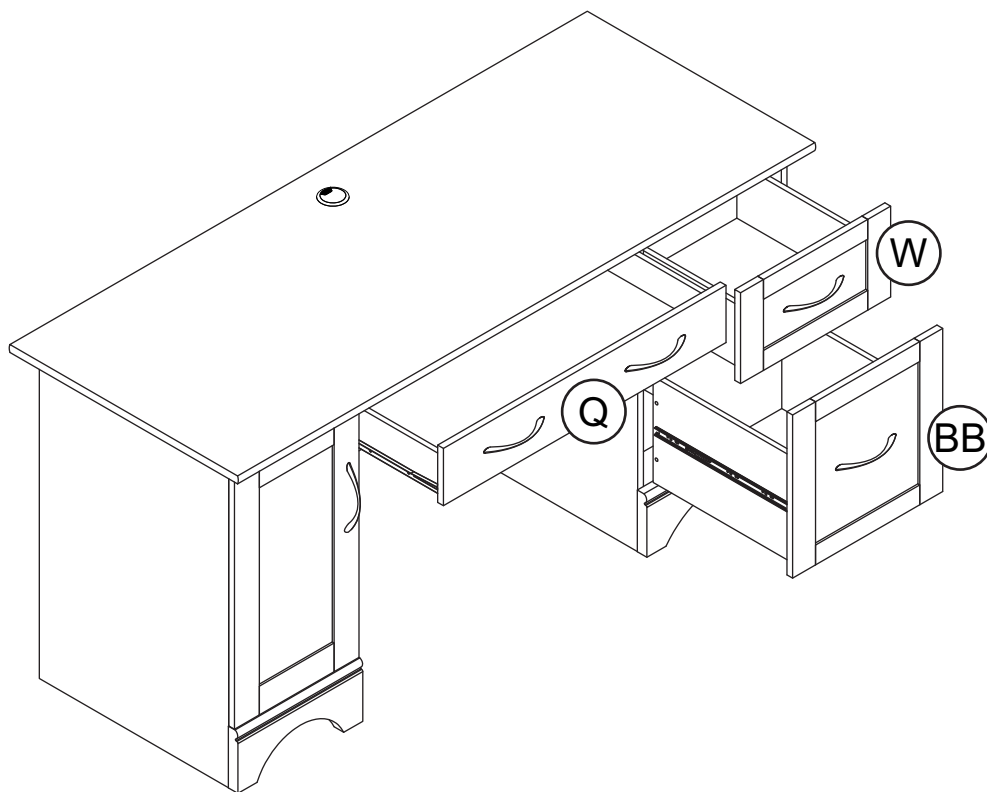

**To Remove Drawer, If Needed**

- Pull the drawer fully open so levers are visible.
- Push up on left side lever and down on right side lever.
- Holding levers in place, pull drawer toward you.

**Pour retirer le tiroir, si nécessaire**

- Tirer le tiroir complètement ouvert afin que les leviers sont visibles.
- Pousser le levier sur le côté gauche vers le haut et pousser le levier sur le côté droit vers le bas.
- Tout en maintenant les leviers en place, tirer le tiroir vers vous.

**Para retirar el cajón, si es necesario**

- Jale el cajón hasta abrirlo por completo, así las palancas quedarán a la vista.
- Empuje hacia arriba la palanca del lado izquierdo y hacia abajo la palanca del lado derecho.
- Mantenga las palancas en su lugar, jale el cajón hacia usted.

## **Office Depot, LLC. Limited Five Year Product Warranty**

This limited warranty covers the original purchase of new product used for normal commercial, personal or household use. Office Depot, LLC. (Office Depot) warrants its products will be free from defects in materials and workmanship (normal wear and tear excepted), for five (5) years from the date of purchase, except as provided below. Office Depot, at its option, will replace with a comparable product, free of charge, any product purchased from it that fails under normal use as a result of such defect. This warranty does not apply to damage caused by fire, accident, negligence, misuse, use other than as stated in product instructions, improper cleaning or other circumstances not directly attributable to defects in materials and workmanship.

**Natural variations occurring in wood or other materials will not be considered defects, and Office Depot does not warrant the color-fastness or matching of colors, grains, or textures of such materials. This warranty does not apply to: modifications of the product, attachments to the product not approved by Office Depot, and products that were not installed, used, or maintained in accordance with product instructions and warnings.**

**This warranty has the following exceptions: Fabrics, foam, veneer finishes and other covering materials are warranted for three years from date of purchase.**

Proof of purchase is required in the form of a receipt (copy or original) to validate warranty. Warranty claims without the receipt may be rejected.

If Office Depot chooses to provide a refund for such product, it will be fulfilled in the form of an Office Depot Merchandise card. Claims fulfilled in this manner take approximately 30 days to process.

OFFICE DEPOT PROVIDES THIS LIMITED WARRANTY IN LIEU OF ALL OTHER WARRANTIES EITHER EXPRESSED OR IMPLIED. EXPRESSLY EXCLUDED ARE ALL WARRANTIES OF FITNESS FOR A PARTICULAR PURPOSE OR MERCHANTABILITY. OFFICE DEPOT'S SOLE OBLIGATION AND THE USER'S EXCLUSIVE REMEDY UNDER THIS WARRANTY SHALL BE LIMITED TO THE REPAIR, REFUND (IN THE FORM OF AN OFFICE DEPOT MERCHANDISE CARD) OR REPLACEMENT AT OFFICE DEPOT'S SOLE DISCRETION AND COST, OF PRODUCT OR COMPONENTS.

IN NO EVENT SHALL OFFICE DEPOT, ITS AFFILIATES, SUBSIDIARIES OR PARENT COMPANIES BE RESPONSIBLE FOR CONSEQUENTIAL, SPECIAL, OR INCIDENTAL DAMAGES ARISING OUT OF A CLAIM OF DEFECTIVE PRODUCT EVEN IF OFFICE DEPOT HAS BEEN ADVISED OF THE POSSIBILITY OF SUCH DAMAGES.

SOME STATES OR PROVINCES DO NOT ALLOW THE EXCLUSION OF IMPLIED WARRANTIES OR LIMITATIONS ON HOW LONG AN IMPLIED WARRANTY LASTS OR THE EXCLUSION OR LIMITATION OF INCIDENTAL OR CONSEQUENTIAL DAMAGES SO THE ABOVE LIMITATIONS MAY NOT APPLY TO YOU. THIS WARRANTY GIVES YOU SPECIFIC LEGAL RIGHTS, AND YOU MAY ALSO HAVE OTHER RIGHTS WHICH MAY VARY BY STATE OR PROVINCE.

THIS WARRANTY APPLIES ONLY TO THE U.S. AND CANADA.

### **Service Instructions**

Please call: 1-844-327-8600 or send email [cs@homenationsinc.net](mailto:cs@homenationsinc.net) for warranty service (Mon-Fri 8am to 5:30pm CST).

## **Office Depot, LLC. Garantie limitée de cinq (5) ans**

Cette garantie limitée couvre les produits neufs utilisés dans le cadre d'applications commerciales ou domestiques normales. Office Depot, LLC. (Office Depot) garantit ses produits contre les défauts de matériel et de main-d'oeuvre (à l'exception de l'usure normale) durant cinq (5) ans à compter de la date d'achat, à l'exception des conditions ci-dessous. Office Depot, à son gré, remplacera sans frais tout produit défectueux dans des conditions d'usure normale par un produit comparable. La présente garantie ne s'applique pas aux dommages causés par le feu, un accident, la négligence, l'usage abusif, le non-respect des instructions, un nettoyage inapproprié ou autre circonstance non directement attribuable à des défauts de matériel et de main-d'oeuvre.

**Les variations naturelles du bois et des autres matériaux utilisés ne sont pas considérées comme des défauts, et Office Depot ne garantit pas les couleurs, les grains et les textures de ces matériaux. La présente garantie ne s'applique pas aux produits modifiés, aux fixations non approuvées par Office Depot et aux produits n'ayant pas été installés, utilisés et entretenus conformément aux instructions et aux avertissements fournis avec le produit.**

**Les tissus, la mousse, les placages et les autres matériaux de recouvrement sont garantis pendant trois (3) ans à compter de la date d'achat.**

Une preuve d'achat sous forme de reçu (original ou photocopie) est exigée pour valider la garantie, sans quoi les réclamations au titre de la garantie peuvent être rejetées.

Si Office Depot décide de rembourser le prix d'achat d'un tel produit, le remboursement sera offert sous forme de carte d'achat Office Depot. Veuillez allouer 30 jours pour le traitement des réclamations.

CETTE GARANTIE EST FOURNIE EN LIEU ET PLACE DE TOUTE AUTRE GARANTIE. SONT EXCLUES TOUTES LES GARANTIES D'ADÉQUATION À UN USAGE SPÉCIFIQUE ET DE QUALITÉ SATISFAISANTE. LA SEULE OBLIGATION DE OFFICE DEPOT ET VOTRE SEUL RECOURS EN VERTU DE CETTE GARANTIE SONT LIMITÉS À LA RÉPARATION DU PRODUIT, AU REMBOURSEMENT SOUS FORME DE CARTE D'ACHAT OFFICE DEPOT OU AU REMPLACEMENT DU PRODUIT OU DE COMPOSANTS À SES FRAIS.

OFFICE DEPOT, SES FILIALES, SES COMPAGNIES ASSOCIÉES ET SES SOCIÉTÉS MÈRES NE PEUVENT ÊTRE TENUES RESPONSABLES DES DOMMAGES INDIRECTS OU PARTICULIERS INHÉRENTS À UNE RÉCLAMATION POUR PRODUIT DÉFECTUEUX MÊME SI LA POSSIBILITÉ D'UN TEL DOMMAGE A ÉTÉ DÉJÀ ÉTÉ PORTÉE À LA CONNAISSANCE D'OFFICE DEPOT.

CERTAINS ÉTATS ET CERTAINES PROVINCES INTERDISANT L'EXCLUSION OU LES RESTRICTIONS DE DURÉE DES GARANTIES IMPLICITES OU L'EXCLUSION DES DOMMAGES INDIRECTS, LES RESTRICTIONS CI-DESSUS PEUVENT NE PAS S'APPLIQUER À VOUS. LA PRÉSENTE GARANTIE VOUS CONFÈRE DES DROITS JURIDIQUES SPÉCIFIQUES ET VOUS POUVEZ DISPOSER D'AUTRES DROITS, LESQUELS PEUVENT VARIER SELON L'ÉTAT OU LA PROVINCE.

CETTE GARANTIE S'APPLIQUE UNIQUEMENT AU CANADA ET AUX ÉTATS-UNIS.

### **Procédure de réclamation en vertu de la garantie**

Pour faire une réclamation, composez le 1 844 327 8600 ou envoyez courriel [cs@homenationsinc.net](mailto:cs@homenationsinc.net) (lundi au vendredi de 8 h à 17:30 h Heure Centrale).



## **Office Depot, LLC. Garantía limitada de cinco años para el producto**

Esta garantía limitada cubre la adquisición original de un producto nuevo utilizado con fines comerciales, personales o domésticos normales. Office Depot, LLC. (Office Depot) garantiza que sus productos estarán exentos de defectos materiales y de fabricación (a excepción de los derivados de un uso y desgaste normal) durante cinco (5) años a partir de la fecha de compra del producto, con la salvedad de lo dispuesto a continuación. Office Depot, a su discreción, sustituirá de forma gratuita por un producto de características similares cualquier producto adquirido que no soporte unas condiciones de uso normales como consecuencia de dicho defecto. Esta garantía no se aplica a daños causados por incendio, accidente, negligencia, uso incorrecto o cualquier otro uso no especificado en las instrucciones del producto, así como a daños causados por una limpieza incorrecta o por otras circunstancias no atribuibles de forma directa a defectos en los materiales y la fabricación.

**Los cambios atribuibles a la propia naturaleza de la madera u otros materiales no se considerarán defectos y Office Depot no garantiza la resistencia del color o la coincidencia del color, el veteado o la textura de dichos materiales. Esta garantía no se aplica a: modificaciones del producto, accesorios del producto no aprobados por Office Depot y productos no instalados, utilizados o mantenidos de acuerdo a las instrucciones y advertencias del producto.**

**Esta garantía cuenta con las siguientes excepciones: el tejido, la espuma, el acabado de chapa y el resto de materiales de revestimiento tienen una garantía de tres años a partir de la fecha de compra.**

Se requiere el recibo de compra (copia u original) para validar la garantía. Los reclamos relacionados con la garantía podrían ser rechazados si no se presenta dicho recibo.

En el caso de que Office Depot decida reembolsar dicho producto, este reembolso se realizará mediante una tarjeta comercial de Office Depot. Las reclamaciones realizadas a través de este método se procesarán en aproximadamente 30 días.

ESTA GARANTÍA LIMITADA DE OFFICE DEPOT SUSTITUYE A TODAS LAS DEMÁS GARANTÍAS, YA SEAN EXPLÍCITAS O IMPLÍCITAS. QUEDAN EXPRESAMENTE EXCLUIDAS TODAS LAS GARANTÍAS DE ADECUACIÓN PARA UN DETERMINADO FIN O COMERCIALIZABILIDAD. LA ÚNICA OBLIGACIÓN DE OFFICE DEPOT Y EL ÚNICO RECURSO DEL USUARIO EN VIRTUD DE ESTA GARANTÍA CONSISTIRÁ EN LA REPARACIÓN, REEMBOLSO (MEDIANTE UNA TARJETA COMERCIAL DE OFFICE DEPOT) O SUSTITUCIÓN, SEGÚN ESTIME OPORTUNO ODP Y ASUMIENDO TODOS LOS COSTES, DEL PRODUCTO O SUS COMPONENTES.

EN NINGÚN CASO OFFICE DEPOT, SUS AFILIADOS, SUBSIDIARIOS O EMPRESAS MATRICES SERÁN RESPONSABLES DE DAÑOS DERIVADOS, ESPECIALES O NO INTENCIONADOS PROCEDENTES DE UNA RECLAMACIÓN POR UN PRODUCTO DEFECTUOSO, AUNQUE SE HAYA ADVERTIDO A OFFICE DEPOT DE LA POSIBILIDAD DE TALES DAÑOS.

ALGUNAS ESTADOS O PROVINCIAS NO PERMITEN LA EXCLUSIÓN DE GARANTÍAS IMPLÍCITAS, LAS LIMITACIONES SOBRE LA DURACIÓN DE UNA GARANTÍA IMPLÍCITA O LA EXCLUSIÓN O LIMITACIÓN DE DAÑOS DERIVADOS O NO INTENCIONADOS, POR LO QUE ES POSIBLE QUE LAS LIMITACIONES MENCIONADAS NO SE APLIQUEN EN SU CASO. ESTA GARANTÍA OTORGA AL USUARIO DERECHOS LEGALES ESPECÍFICOS; ADEMÁS, ES POSIBLE QUE GOCE DE OTROS DERECHOS QUE VARÍAN SEGÚN EL ESTADO O LA PROVINCIA.

ESTA GARANTÍA SE APLICA SÓLO EN EE. UU. Y CANADÁ.

### **Instrucciones de servicio**

Llame al 1-844-327-8600 o enviar correo [cs@homenationsinc.net](mailto:cs@homenationsinc.net) para obtener más información sobre el servicio de garantía (lunes a viernes de 8am a 5:30pm hora del Centro de EE. UU.).