

realspace®

Broadstreet  
Collection

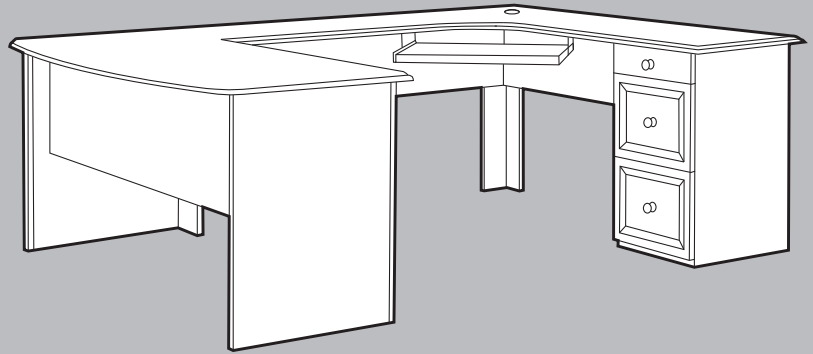

## Contoured U-Shaped Desk

Assembly instructions and warranty information

## Bureau en U Profilé

Instructions pour l'assemblage et information sur la garantie

## Escritorio en "U" Contorneado

Instrucciones para el ensamblaje e información sobre la garantía

**For customer support, call 1-800-949-9974**

Pour le support client, appelez le 1-800-949-9974

Llame para asistencia al cliente 1-800-949-9974

Date Manufactured / Date de fabrication / Fecha de manufactura: \_\_\_\_\_

Lot # / Nombre de sort / Número de lote: \_\_\_\_\_

version 0320

Items 475-994, 567-249, 2665154

Realspace is a trademark or registered trademark of The Office Club, Inc.  
© 2020 Office Depot, Inc. All Rights Reserved. Made in Vietnam

## **Warning**

**Please use your furniture correctly and safely. Improper use can cause safety hazards, or damage to your furniture or household items. Carefully read the following chart.**

<b>Look out for:</b>	<b>What can happen:</b>	<b>How to avoid:</b>
Children climbing on furniture. A child may try to reach a toy or other object by climbing on furniture. Children will play and be active near a TV.	Risk of injury or death. A child climbing on a piece of furniture or playing with a TV can cause it to tip over.	Never allow children to climb on or play with furniture. Do not place toys, food, etc. on the top shelves and/or drawers. Children may try to climb to reach them out of curiosity.
Overloaded drawers and/or shelves. Improper loading can cause furniture to be top-heavy.	Risk of injury or damage to furniture and/or equipment. Overloaded drawers and/or shelves can break.	Refer to your assembly manual for maximum weight capacities. Load drawers and shelves from the bottom to the top. Place heavier items in lower drawers and/or shelves. Unload drawers and shelves from the top to the bottom before moving the furniture.
Placing a TV on furniture that is not designed to support a TV.	Risk of injury or death. TVs can be very heavy. The weight and location of the picture tube tends to make them unbalanced and prone to tipping forward.	This product is not designed to support a TV.
Improperly moving furniture.	Risk of injury or damage to furniture and/or equipment. Furniture can tip over if not moved carefully over obstacles or across a changing floor surface (ex: from a wood floor to carpeted floor).	Do not push furniture, especially on carpeted floor. Have someone help you lift the item and place it in its new location. Remove any glass tops, shelves or doors before moving.

Thank you for purchasing this product. We trust that you will be completely satisfied with your product for years to come. This product is backed by a 5 year limited warranty and has been crafted with today's lifestyles in mind.

### **Call Us First!**

#### **DO NOT RETURN TO STORE.**

For immediate help with assembly or product information call our toll-free number:

1-800-949-9974 Mon-Fri 8am to 8pm EST.

Our staff is ready to provide assistance.

Damaged or missing parts ship from our facility in 1-2 business days.

### **The maximum recommended weight allowance is 284 lbs (128.8 kg) for top surface.**

The maximum recommended weight allowance is 23 lbs (10.4 kg) for keyboard tray. 25 lbs (11.4kg) equally distributed per tower file drawer. Lot # is located on a side panel. Please record it in space below for future reference. Record date of purchase below and save this booklet for future reference. Call for parts & service 1-800-949-9974. For customer support, Vendor label is under the keyboard tray.

**SPECIAL NOTE:** Please read the instruction sheets completely before assembly. Examine all packaging material before discarding carton. Remove any remaining staples from the carton before discarding. Select a smooth work surface which will not scratch or damage parts. Remove all parts from carton and separate into groups as indicated on parts list. Please ensure all parts are included prior to assembly. Use of power tools to complete assembly is not recommended.

**Customer Service 1-800-949-9974**

Date Purchased: \_\_\_\_\_

# Avertissement

Prière d'utiliser le mobilier à bon escient et avec prudence. Une mauvaise utilisation peut être à l'origine de risques d'accident ou peut endommager le mobilier et les articles ménagers. Lire attentivement le tableau suivant.

Faites attention :	Les risques :	Comment éviter :
Enfants monter sur des meubles. Un enfant peut essayer d'atteindre un jouet ou tout autre objet en s'élevant sur des meubles. Les enfants vont jouer et être actifs à proximité du téléviseur.	Risque de blessures voire la mort. Un enfant s'élevant sur un meuble ou jouant avec une télé peut la faire incliner plus se renverser.	Ne laissez pas les enfants monter ou jouer près de la télé. Ne posez jamais de jouets, nourriture, etc. sur les étagères ou les tiroirs supérieurs. Les enfants pourraient tenter des les attraper par curiosité.
Etagères et/ou tiroirs surchargées. Le chargement impropre peut rendre des meubles instable.	Risque de blessures voire la mort ou dommages aux meubles et/ou au équipement. Etagères/tiroirs surchargées peuvent casser.	Ne jamais excéder les limites de poids indiquées dans les instructions. Charger l'étagères/tiroirs à partir du bas et finir au haut. Placer objets les plus lourds sur l'étagères/tiroirs inférieures. Déchargez les tiroirs et les étagères de haut en bas avant de déplacer les meubles.
Plaçant une télévision sur meubles qui ne sont pas conçus pour supporter une télévision.	Risque de blessures voire la mort. Les téléviseurs peuvent être tres lourds. Le poids et l'emplacement du tube image ont tendance à rendre les téléviseurs instables et enclins à tomber vers l'avant.	Ce produit n'est pas conçu pour supporter une télé.
Meubles qui sont déplacés incorrectement.	Risque de blessures voire la mort ou dommages aux meubles et/ou au équipement. Les meubles peuvent incliner en avant et casser si non déplacé soigneusement au-dessus des obstacles ou à travers une surface changeante (ex: d'un plancher en bois au plancher tapissé).	Ne poussez pas les meubles, en particulier sur un sol avec une moquette. Obtenez l'aide de quelqu'un pour soulever le meuble et placer dans son nouvel emplacement. Désassemblez toutes les tables, étagères ou portes de verre avant de se déplacer.

Nous vous remercions d'avoir acheté ce produit et espérons que vous en serez entièrement satisfait pendant de longues années. Ce produit est couvert par une garantie limitée de 5 ans et a été conçu pour répondre aux besoins d'aujourd'hui.

## N'hésitez pas à nous appeler!

### NE RENVOYEZ PAS LE PRODUIT AU MAGASIN.

Pour obtenir de l'aide lors du montage ou des informations sur le produit, veuillez appeler notre numéro sans frais : 1-800-949-9974, du lundi au vendredi, de 8 h à 20 h HNE.

Notre personnel se fera un plaisir de vous fournir l'aide nécessaire.

Les pièces de rechange seront expédiées depuis notre unité de production dans un délai de 1 à 2 jours ouvrables.

## Le panneau supérieur peut supporter un poids maximal de 128,8 kg (284 lb).

La tablette du clavier peut supporter un poids maximal de 10,4 kg (23 lb). 11.4 kg (25 lb) répartis uniformément sur le tiroir classeur. Le numéro de lot figure sur un panneau latéral. Veuillez l'inscrire dans l'espace ci-dessous à des fins de consultation future. Notez la date d'achat ci-dessous et enregistrez ce guide pour une utilisation ultérieure. Communiquez au besoin avec le service après-vente au 1 800 949-9974. Pour le service à la clientèle, étiquette du fournisseur est sous le plateau de clavier.

**REMARQUE :** Veuillez lire toutes les directives avant de procéder au montage. Examinez tout le matériel d'emballage avant de jeter le carton. Retirez les agrafes de ce dernier avant de le jeter. Choisissez une surface de travail lisse qui ne pourra ni égratigner ni endommager les pièces. Enlevez toutes les pièces du carton et répartissez-les en groupes tel qu'indiqué sur la liste des pièces. Assurez-vous que toutes les pièces ont été incluses avant de commencer le montage. L'utilisation d'outils électriques n'est pas recommandée pour le montage.

Service à la clientèle : 1-800-949-9974

Date d'achat : \_\_\_\_\_



## Advertencia

Por favor use su mueble correctamente y seguramente. El uso impropio puede causar riesgos de seguridad o daño al mueble o artículos domésticos. *Cuidadosamente lea la tabla a continuación.*

Tenga cuidado con:	Puede ocurrir:	Como evitar:
Niños subiéndose a los muebles. Un niño tratará de alcanzar un juguete u otro objeto subiéndose a los muebles. Niños muy activos que juegan cerca del televisor.	Riesgo de lesión o muerte. Un niño subiéndose a un mueble o jugando con el televisor puede causar que se caiga.	Nunca permita que los niños se suban o jueguen con los muebles. No coloque juguetes, comida, etc. sobre las gavetas o repisas superiores. Los niños tratarán de subirse para alcanzarlos o por curiosidad.
Gavetas y repisas con sobrelleno. Colocando objetos de forma incorrecta puede causar el mueble ser inestable.	Riesgo de lesión o muerte o daño al mueble y equipo. Gavetas y repisas con sobrelleno se pueden romper.	Consulte sus instrucciones para el peso máximo permitido. Coloque artículos dentro de las gavetas o sobre las repisas empezando de abajo hacia arriba. Coloque los objetos más pesados en las gavetas o repisas inferiores. Descargue las gavetas y repisas empezando de arriba hacia abajo antes de mover el mueble.
Colocando un televisor sobre un mueble que no es diseñado para un televisor.	Riesgo de lesión o muerte. El televisor puede ser muy pesado. El peso y la localización del tubo de la pantalla lo hace estar fuera de balance y propensa a volcarse.	Este producto no es diseñado para un televisor.
Moviendo muebles de forma incorrecta.	Riesgo de lesión o muerte o daño al mueble y equipo. El mueble puede volcarse o romperse cuando se mueve de forma incorrecta sobre obstáculos o sobre un piso desnivelado (ejemplo: sobre un piso de madera a un piso alfombrado).	No empuje el mueble especialmente sobre la alfombra. Consiga que alguien le ayude a levantar el mueble para poder colocarlo en su lugar. Desensamble cualquier mesa, estante o puerta de vidrio antes de mover.

Le damos las gracias por adquirir este producto. Confiamos en que quede completamente satisfecho con sus prestaciones. Este producto tiene una garantía limitada de 5 años y ha sido creado atendiendo al estilo de vida de hoy día.

### ANTES DE DEVOLVERLO, ¡LLÁMENOS!

Si desea más información sobre el montaje, llámenos sin coste adicional alguno al siguiente teléfono de 8 de la mañana a 8 de la tarde de lunes a viernes (hora del Este de EE. UU.): +1-800-949-9974 Nuestro personal le proporcionará toda la ayuda que necesite.

Las piezas dañadas o no adjuntadas saldrán de nuestras instalaciones en uno o dos días hábiles.

### El peso máximo recomendado es de 128,8 kg (284 libras) en el tablero.

El peso máximo recomendado es de 10,4 kg (23 libras) en el tablero. 11.4 kg (25 libras) distribuidos de manera equitativa en el cajón archivador. El lote # está ubicado en un panel lateral. Anótelos en el espacio siguiente para poder consultarlo en el futuro. Anote la fecha de compra en el espacio a continuación y guarde este documento para poder consultarlo. El teléfono de asistencia y repuestos es 1-800-949-9974. Para servicio al cliente, etiqueta del proveedor se encuentra bajo la bandeja del teclado.

**NOTA:** Lea atentamente toda la hoja de instrucciones antes de comenzar el montaje. Antes de deshacerse del embalaje compruebe que no ha olvidado nada en su interior. Seleccione una superficie de trabajo lisa que no raye ni dañe las partes. Quite cualquier grapa u accesorio fijado al cartón antes de tirarlo. Una vez apartadas las piezas, sepárelas en grupos como se indica en la lista. Cerciórese de que tiene todas las piezas antes de comenzar el ensamblaje. No se recomienda utilizar herramientas muy potentes para ensamblar este mueble.











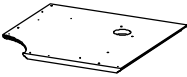
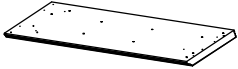

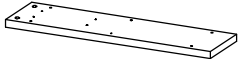
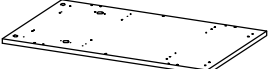
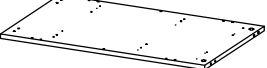

Nuestro teléfono de atención al cliente es +1-800-949-9974

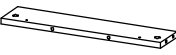









Fecha de compra: \_\_\_\_\_

## PARTS LIST

## LISTE DES PIÈCES

## LISTA DE PIEZAS

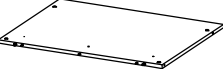
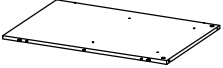









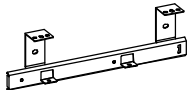
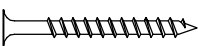
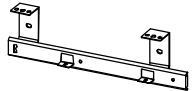
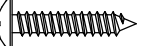

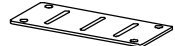



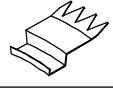



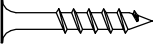

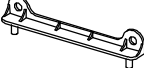

Name/Nom/Nombre	Part/Pièce/Pieza	Qty. Qté Cantidad
<b>A</b> Corner Top Panneau supérieur du meuble de coin Tablero de esquina		1
<b>B</b> Return Top Panneau supérieur du retour Tablero de esquina		1
<b>C</b> Cabinet Top Panneau supérieur du meuble-classeur Tablero de armario		1
<b>D</b> Return Leg Patte du retour Pata plegable		1
<b>E</b> Cabinet Inner Side Panneau intérieur du classeur Lateral interior del armario		1
<b>F</b> Cabinet Outer Side Panneau extérieur du classeur Lateral exterior del armario		1
<b>G</b> Return Rear Panel Panneau arrière du retour Panel posterior plegable		1
<b>H</b> Cabinet Rear Panel Panneau arrière du meuble-classeur Panel posterior del armario		1
<b>J</b> Cabinet Back Panel Panneau arrière du classeur Panel trasero del armario		1
<b>K</b> Base Rear Support Support de base Soporte trasero de la base		1
<b>L</b> Base Rear Façade de support Soporte trasero de la base		1
<b>M</b> Keyboard Tablette de clavier Parte trasera de la base		1
<b>N</b> Corner Right Leg Patte droite du meuble de coin Pata de esquina derecha		1
<b>O</b> Corner Left Leg Patte gauche du meuble de coin Pata de esquina izquierda		1
<b>P</b> Box Drawer Front Face avant du tiroir simple Parte frontal del cajón		1
<b>Q</b> Box Drawer Left Side Côté gauche du tiroir simple Panel lateral izquierdo del cajón		1
<b>R</b> Box Drawer Right Side Côté droit du tiroir simple Panel lateral derecho del cajón		1

Name/Nom/Nombre	Part/Pièce/Pieza	Qty. Qté Cantidad
<b>S</b> Box Drawer Back Panneau arrière du tiroir simple Parte trasera del cajón		1
<b>T</b> Box Drawer Bottom Fond du tiroir simple Parte inferior del cajón		1
<b>V</b> File Drawer Front Face avant du tiroir classeur Parte frontal del cajón		2
<b>W</b> File Drawer Left Side Côté gauche du tiroir classeur Panel lateral izquierdo del cajón archivador		2
<b>X</b> File Drawer Right Side Côté droit du tiroir classeur Panel lateral derecho del cajón archivador		2
<b>Y</b> File Drawer Back Panneau arrière du tiroir classeur Parte trasera del cajón archivador		2
<b>Z</b> File Drawer Bottom Fond du tiroir classeur Parte inferior del cajón archivador		2
<b>AA</b> Big Desk Top Panneau supérieur du bureau Tablero del escritorio grande		1
<b>BB</b> Big Desk Left Side Panneau latéral gauche du bureau Panel lateral izquierdo del escritorio grande		1
<b>CC</b> Big Desk Right Side Panneau latéral droit du bureau Panel lateral derecho del escritorio grande		1
<b>DD</b> Big Desk Rear Panneau arrière du bureau Parte trasera del escritorio grande		1
<b>EE</b> Big Desk Side Rail Languette de recouvrement Riel lateral del escritorio grande		3

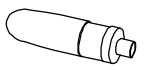

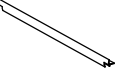
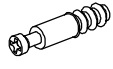



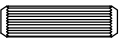



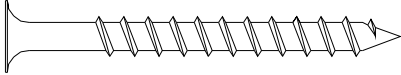

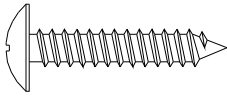

## PARTS LIST

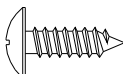
## LISTE DES PIÈCES

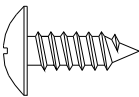
## LISTA DE PIEZAS

Name/Nom/Nombre	Part/Pièce/Pieza	Qty. Qté Cantidad	Spare Épargner Sobrante	Name/Nom/Nombre	Part/Pièce/Pieza	Qty. Qté Cantidad	Spare Épargner Sobrante
A1 Left Keyboard Slide Coulisse gauche de tablette du clavier Teclado corredero izquierdo		1		S1 2" Screw Vis de 51mm Tornillo de 51mm		6	1
B1 Right Keyboard Slide Coulisse droite de tablette du clavier Teclado corredero derecho		1		S2 1" Screw Vis de 25mm Tornillo de 25mm		4	1
C1 Knob Bouton Tornillo de apriete		3		S3 1/2" Screw Vis de 12mm Tornillo de 12mm		8	1
D1 Connecting Pan Plaque de connexion Tubo de conexión Tubo de conexión		6		S4 1/2" Screw Vis de 12mm Tornillo de 12mm		32	1
E1 Socket Prise Conector		1		S5 9/16" Screw Vis de 14mm Tornillo de 14mm		40	1
E2 Clip Clip Clip		2		S6 5/8" Bolt Boulon de 16 mm Perno de 16 mm		2	1
F1 Plastic Cap Capuchon en plastique Taponés de plástico		27	1	S7 1" Bolt Boulon de 25 mm Perno de 25 mm		1	1
G1 Foot Extrémité de patte Terminación de pata		12		S8 1-1/4" Screw Vis de 32mm Tornillo de 32mm		12	1
H1 Plastic Corner Bracket Support de coin en plastique Ménsula plástica en L		2		T1 File Drawer Slide Glissière de tiroir classeur Baranda de archivador corredera		4	
J1 Panel Connector Connecteur de panneau Conector de paneles		4		U1 Left Box Drawer Slide Glissière gauche de tiroir simple Cajón archivador corredero izquierdo		1	
K1 Panel Connector Connecteur de panneau Conector de paneles		2		V1 Right Box Drawer Slide Glissière droite de tiroir simple Cajón archivador corredero derecho		1	
L1 Plastic Cap Capuchons en plastique Taponés de plástico		2		W1 File Hanger Support de dossiers Colgador de carpetas		2	
M1 Glue Colle Pegamento		1		X1 File Rail Rail pour chemises Baranda de archivo		2	
N1 Cam Roulette à blocage Leva		6	1	Y1 File Rail Rail pour chemises Baranda de archivo		4	
O1 Pin Cheville Pasador		6	1	Z1 Lock Verrou Bloqueo		1	
P1 Cam Came Leva		29	1				
Q1 Pin Cheville Pasador		29	1				
R1 Dowel Goujon Taquete		20	1				

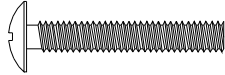
COMPARISON SIZE CHART  
 TABLEAU DE COMPARAISON DE TAILLES  
 TABLA DE COMPARACIÓN DE TAMAÑOS

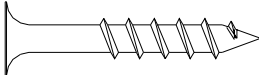
	2" Screw Vis de 51mm Tornillo de 51mm	
	1" Screw Vis de 25mm Tornillo de 25mm	
	1/2" Screw Vis de 12mm Tornillo de 12mm	
	1/2" Screw Vis de 12mm Tornillo de 12mm	
	9/16" Screw Vis de 14mm Tornillo de 14mm	
	5/8" Bolt Boulon de 16 mm Perno de 16 mm	
	1" Bolt Boulon de 25 mm Perno de 25 mm	
	1-1/4" Screw Vis de 32mm Tornillo de 32mm	

### Installation of Cams and Pins :

Screw the Pin into hole. To set Cams correctly, ensure the arrow on the Cam head points to the hole of the Pin it is locking. Lock Cam by turning Cam head one third clockwise with screwdriver. Do not overtighten. Please don't use an electric screwdriver to assemble the unit.

### Installation des roulettes à blocage et des chevilles :

Vissez la cheville à l'intérieur du trou. assurez-vous que la flèche sur le dessus de la roulette pointe vers le trou de la cheville à bloquer. Verrouillez la roulette à blocage en tournant le dessus de la roulette d'un tiers de tour en sens horaire à l'aide d'un tournevis. Ne serrez pas trop. Veuillez ne pas utiliser un tournevis électrique pour assembler ce meuble.

### Instalación de levas y pernos :

Atornille el pasador en el agujero, asegúrese de que la flecha en la cabeza de la leva apunta hacia el agujero del pasador que esta asegurando. Asegure la leva girando la cabeza un tercio en el sentido de las agujas del reloj. No la apriete en exceso. No utilice un destornillador eléctrico para ensamblar la unidad.

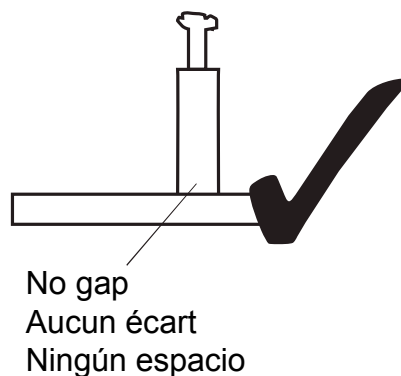
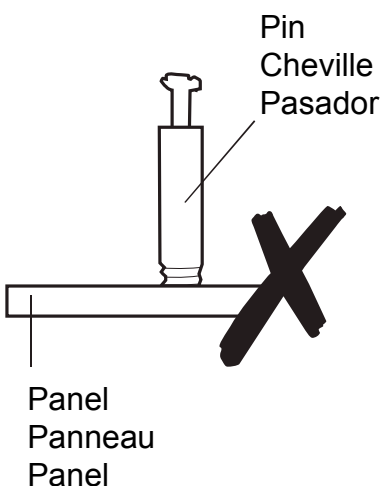
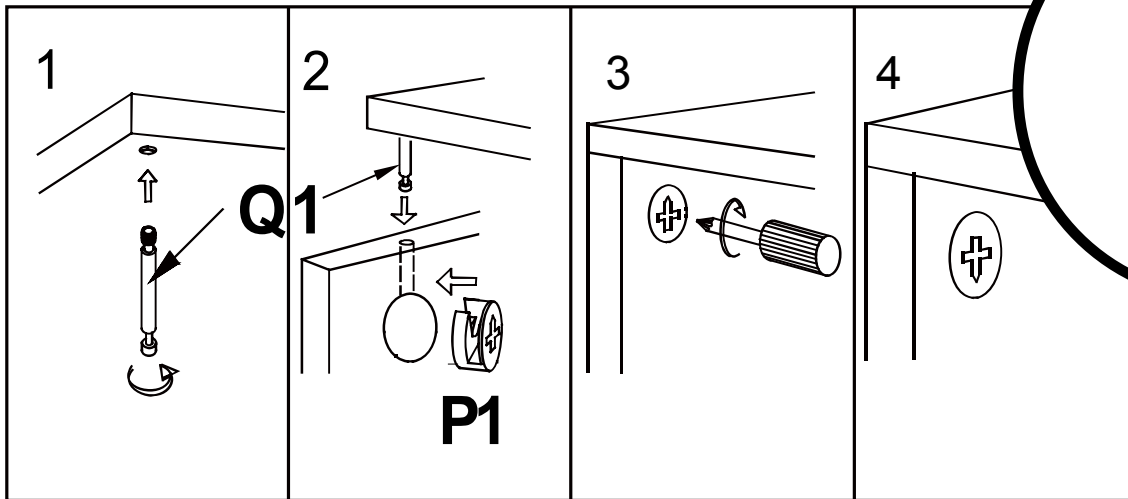



# STEP 1

S<sub>5</sub>

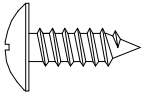

[ 10 ]

J<sub>1</sub>

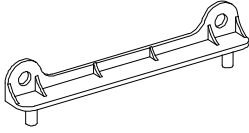

[ 4 ]

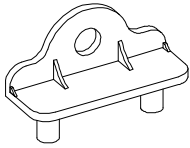

K<sub>1</sub>

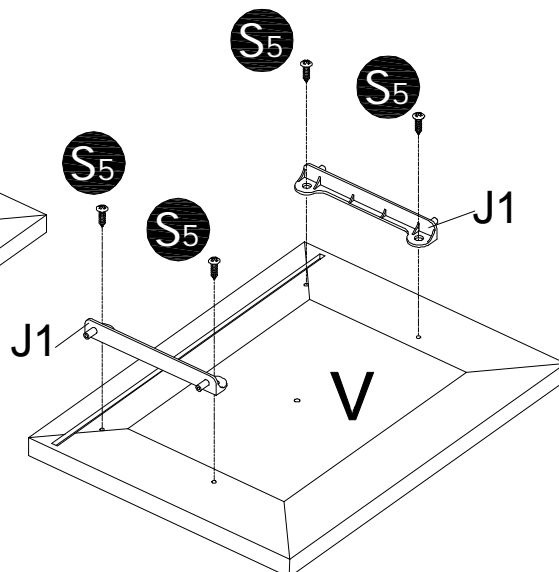
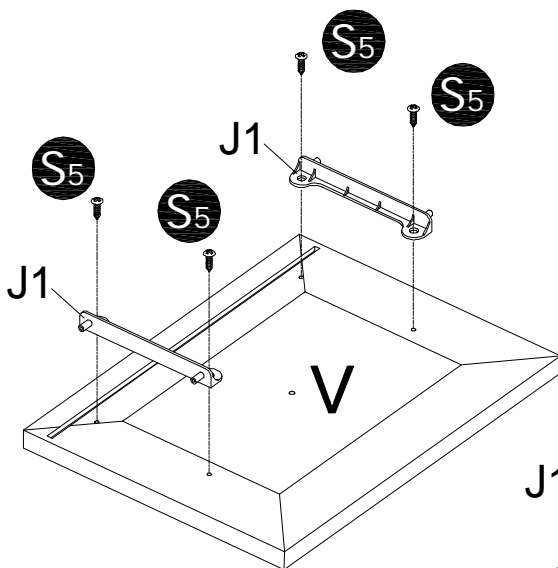
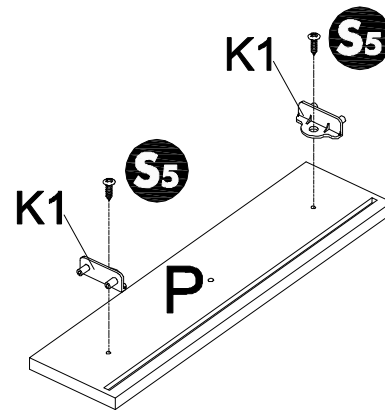
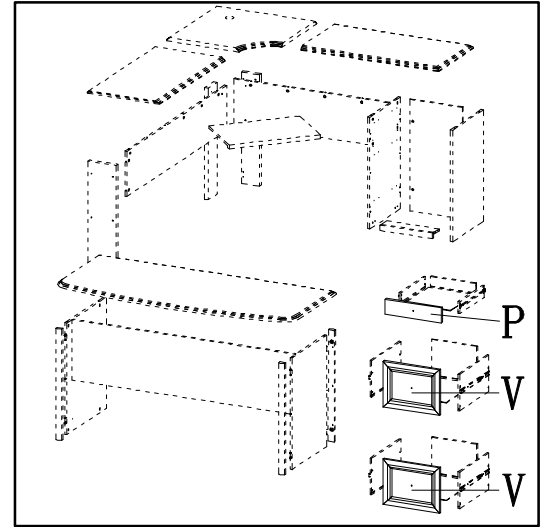

[ 2 ]

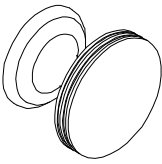
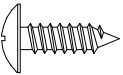

# STEP 2

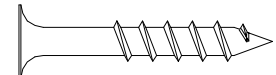
- C1**  [ 1 ]
- S4**  [ 4 ]
- S7**  [ 1 ]
- S8**  [ 4 ]

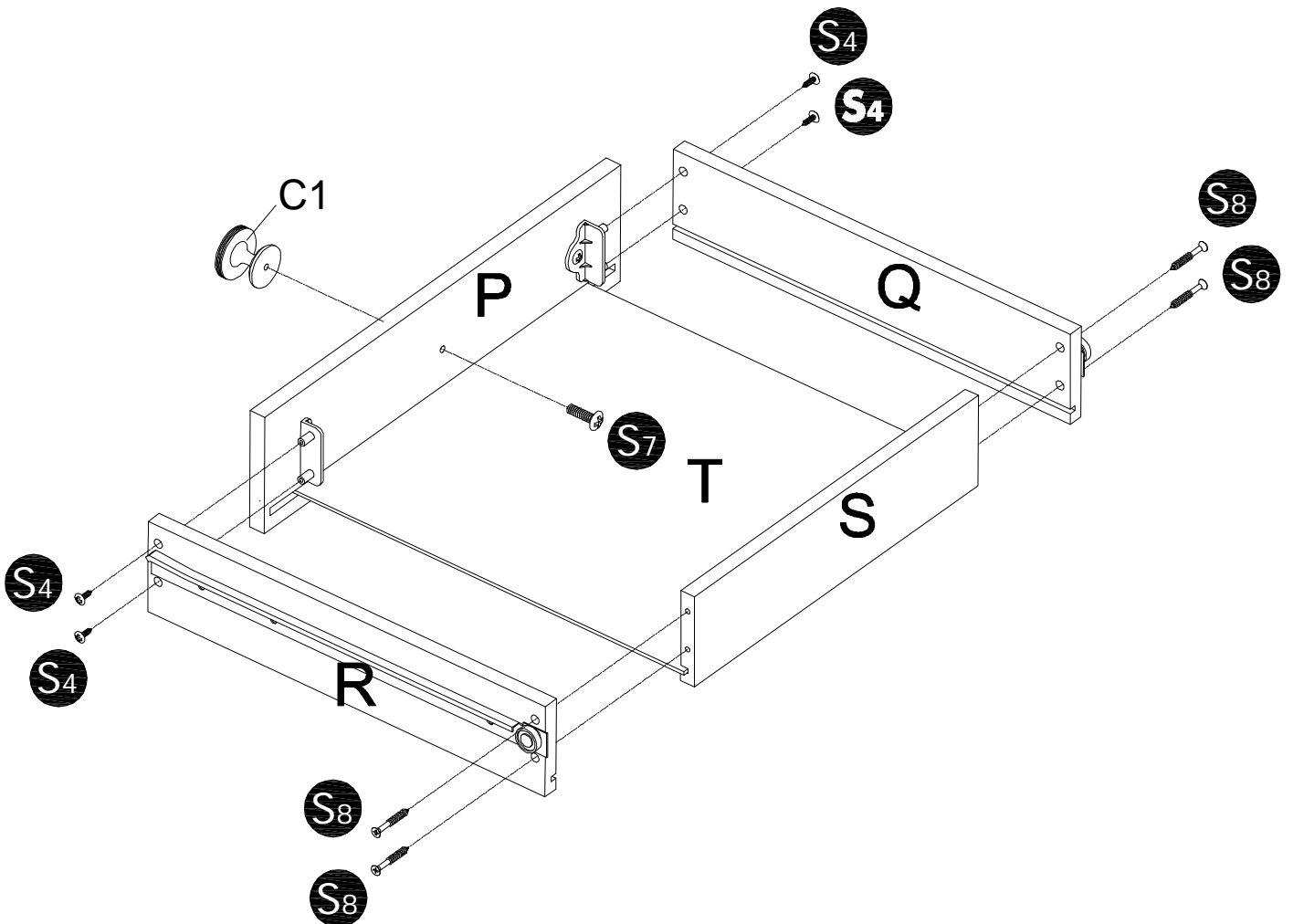
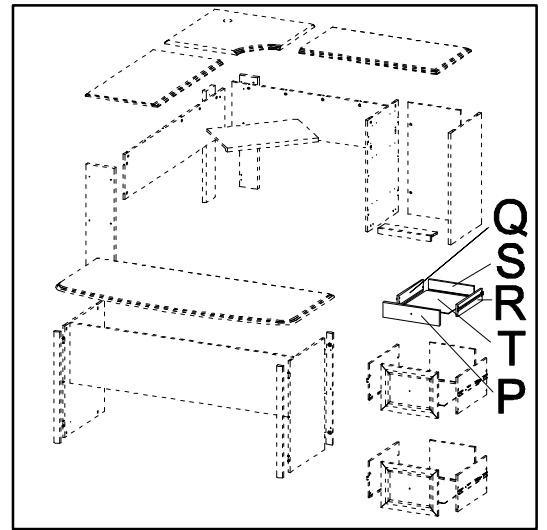

# STEP 3

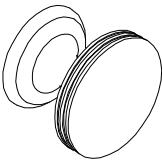
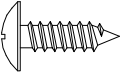
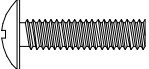
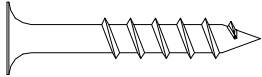
- C1**  [2]
- S4**  [8]
- S6**  [2]
- S8**  [8]

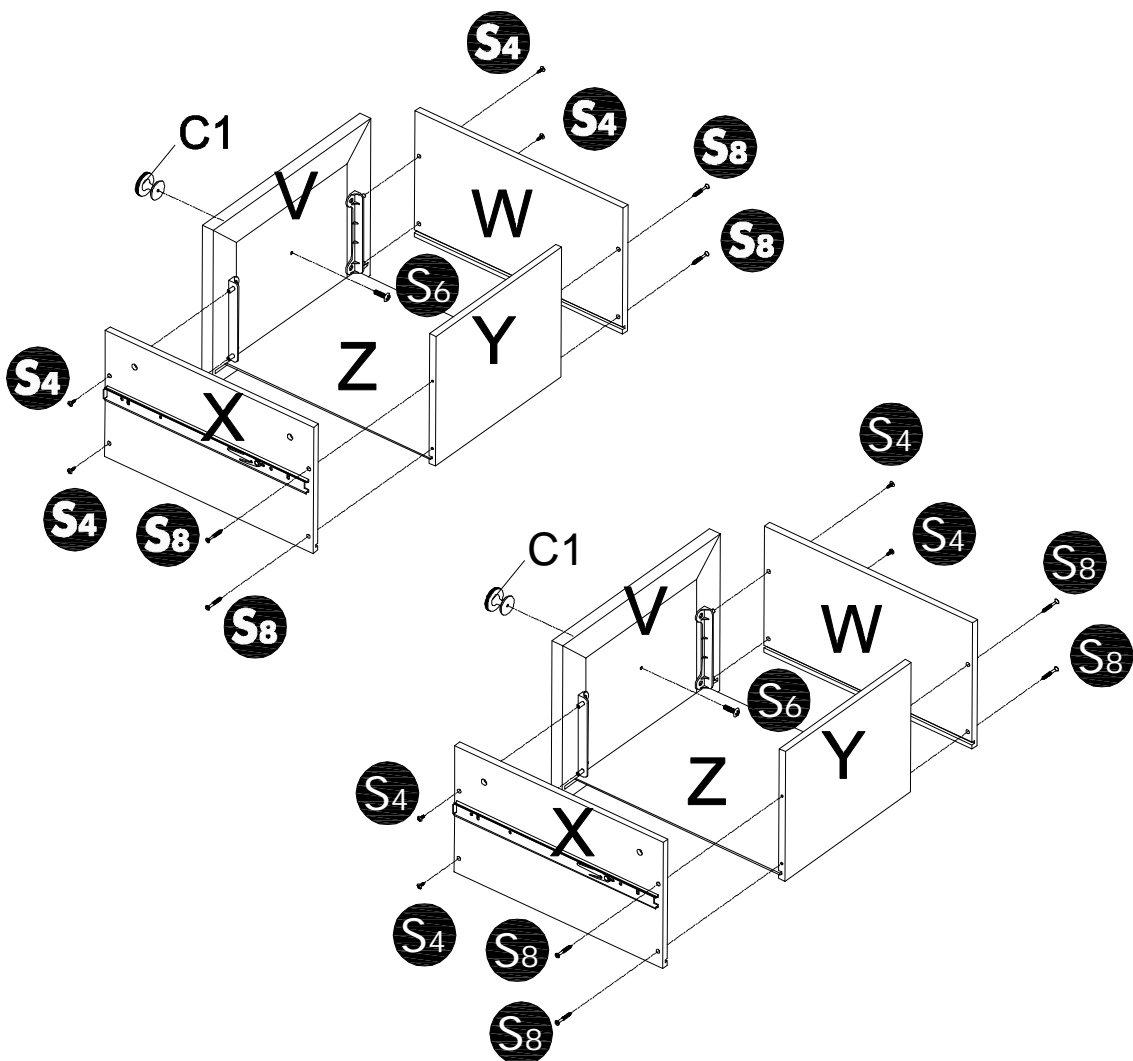
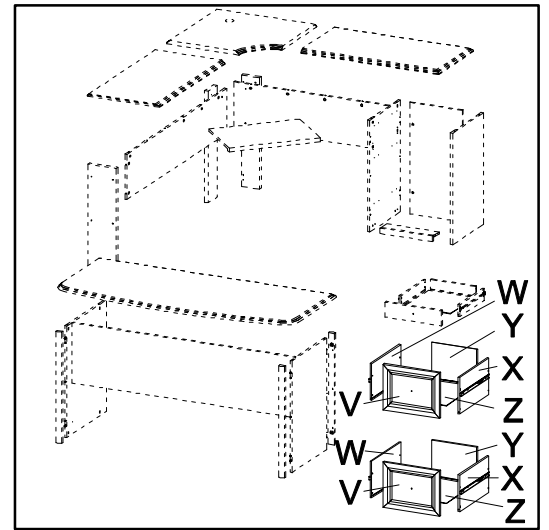

# STEP 4

W<sub>1</sub>



[2]

X<sub>1</sub>



[2]

Y<sub>1</sub>

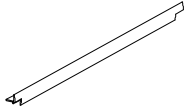

[4]

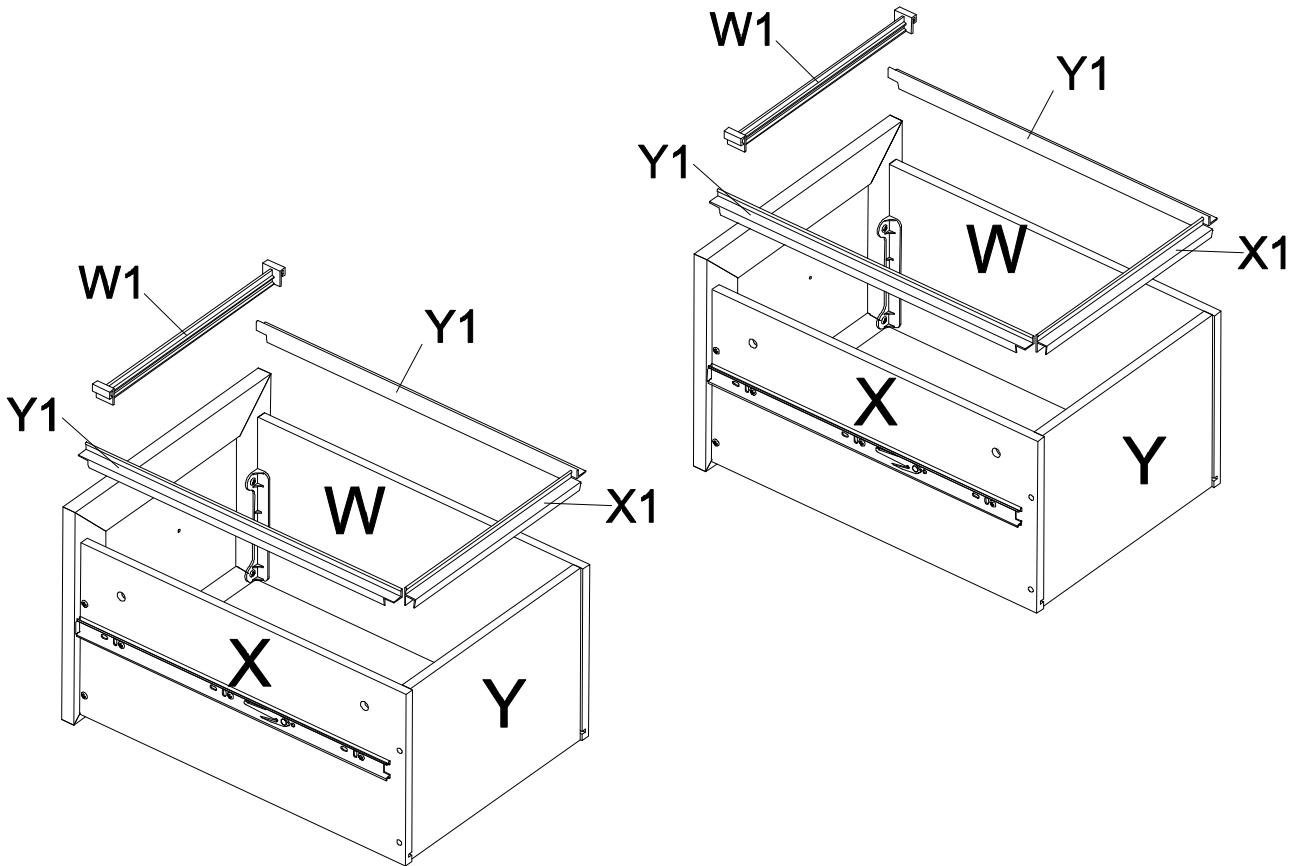
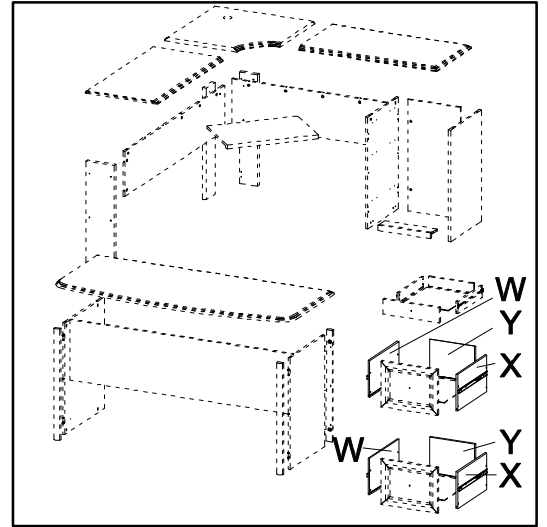

## Desk Set-Up

Before proceeding to the next step, the Desk can be set-up with two configurations, Option “A” and Option “B” as shown on this page.

1. If you choose to set-up your Desk as shown in Option “A” below; proceed to Step 5 and continue the assembly process. The assembly steps for Option “A” ends with Step 42.
2. If you choose to set-up your Desk as shown in Option “B” below; skip Steps 5-42 and continue with the assembly of the Desk with Step 43.

## Assemblage du bureau

Vous devez choisir la configuration finale du bureau avant de passer à l'étape suivante. Le bureau peut être assemblé selon les options A et B présentées ci-dessous.

1. Si vous choisissez la configuration « A », passez à l'étape suivante (5) et continuez la procédure d'assemblage. La procédure d'assemblage de la configuration « A » se termine à l'étape 42.
2. Si vous choisissez la configuration « B », ignorez les étapes 5 à 42 et passez à l'étape 43.

## Instalación del escritorio

Antes de continuar al siguiente paso, le informamos que hay 2 formas de instalar el escritorio, la opción "A" y la opción "B", tal y como se indica en esta página.

1. Si elige instalar el escritorio como se indica en la opción "A", avance hasta el paso 5 y continúe el proceso de montaje. Los pasos del montaje de la opción "A" finalizan en el paso 42.
2. Si elige instalar el escritorio como se indica en la opción "B", omita el paso 5 al 42 y continúe el proceso de montaje del escritorio en el paso 43.

Option “A” - Go to step 5  
Configuration « A » - Passez à l'étape 5.  
Opción "A": ir al paso 5

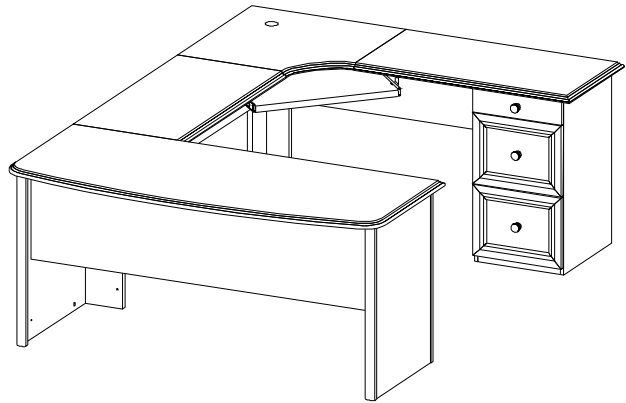

Option “B” - Go to step 43  
Configuration « B » - Passez à l'étape 43.  
Opción "A": ir al paso 43

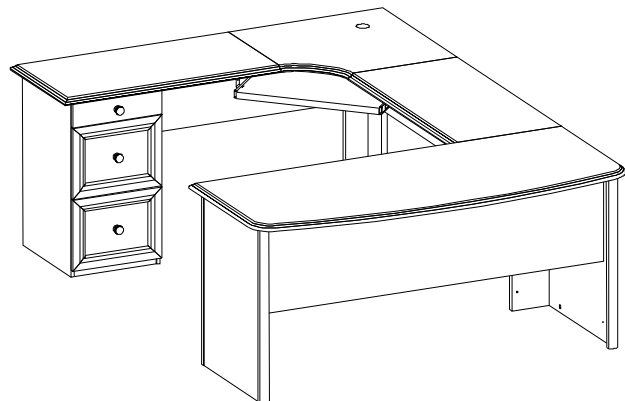

# STEP 5

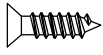
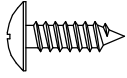
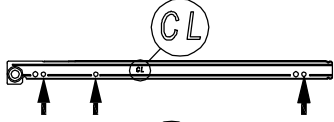
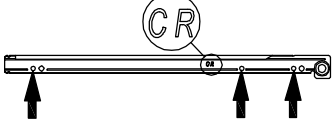
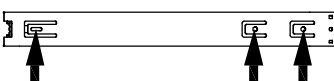
- S<sub>3</sub>**  [ 6 ]
- S<sub>4</sub>**  [ 12 ]
- U<sub>1</sub>**  [ 1 ]
- V<sub>1</sub>**  [ 1 ]
- T<sub>1</sub>**  [ 4 ]

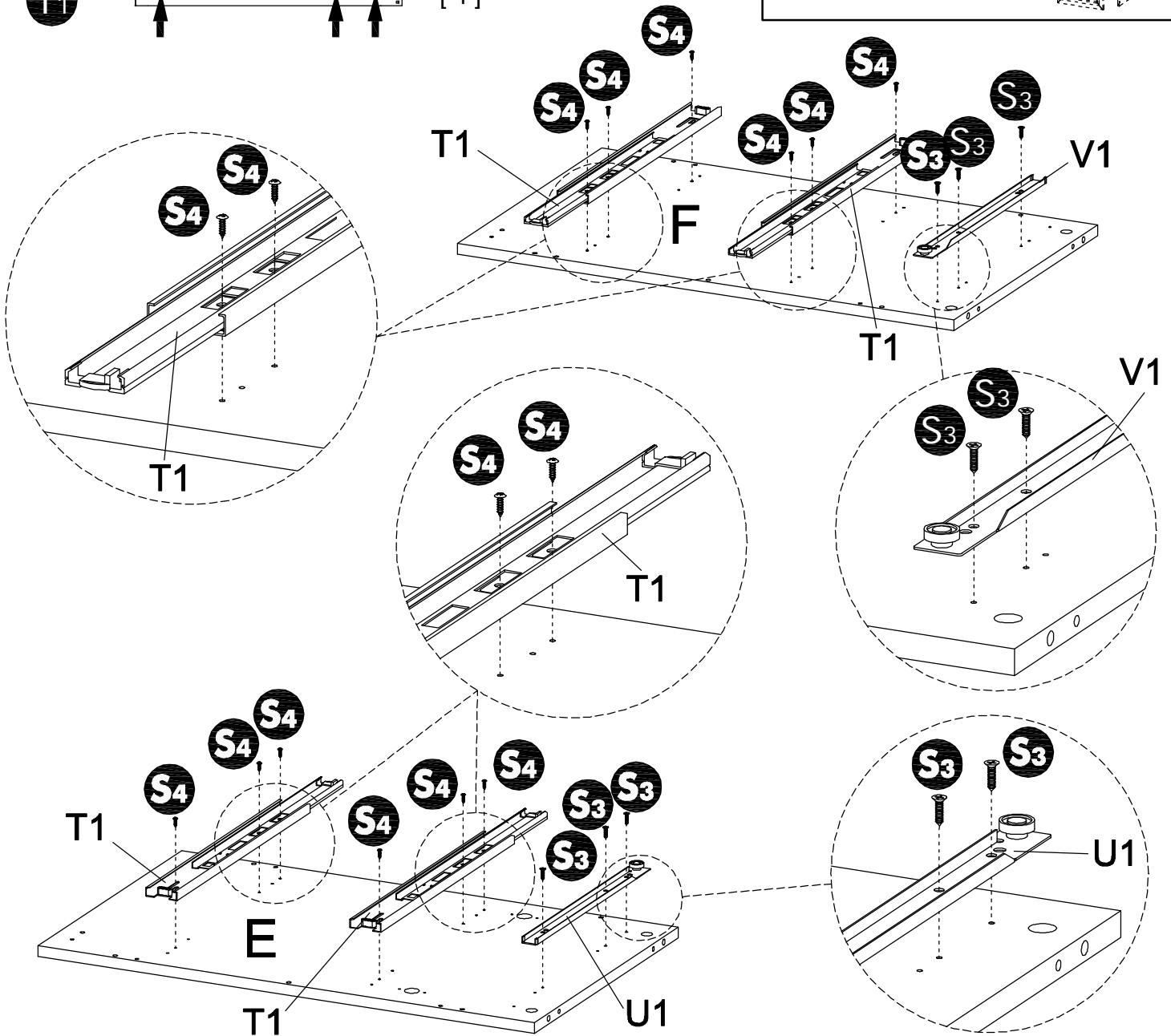
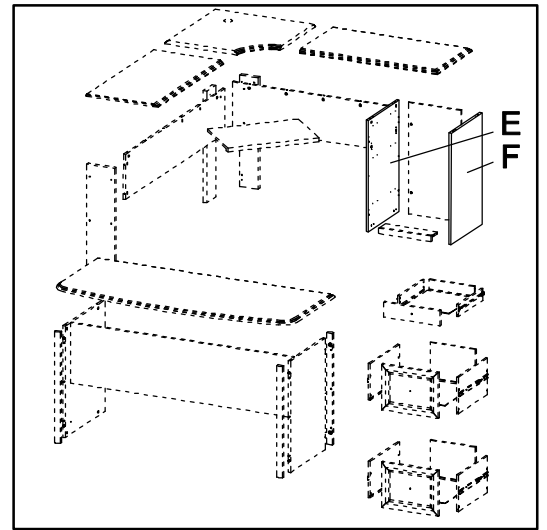

# STEP 6

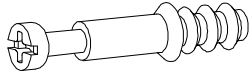
**O<sub>1</sub>**  [6]

**R<sub>1</sub>**  [4]

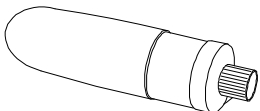
**M<sub>1</sub>** 

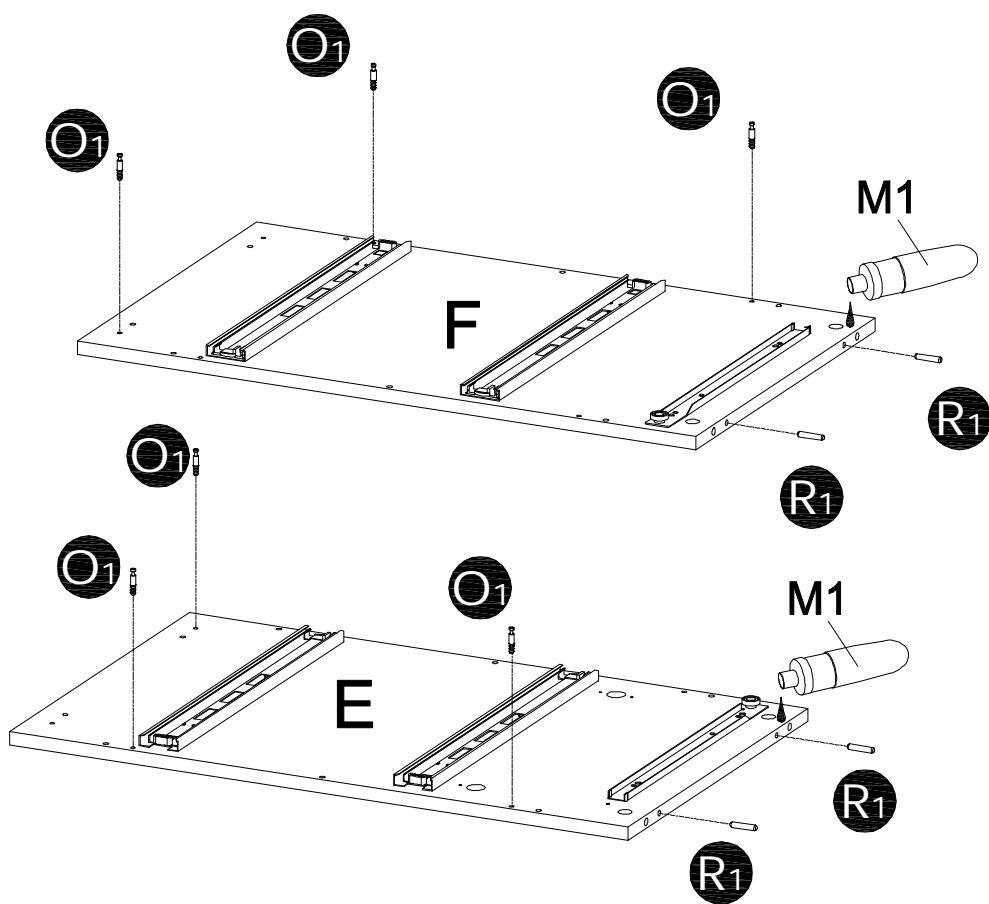
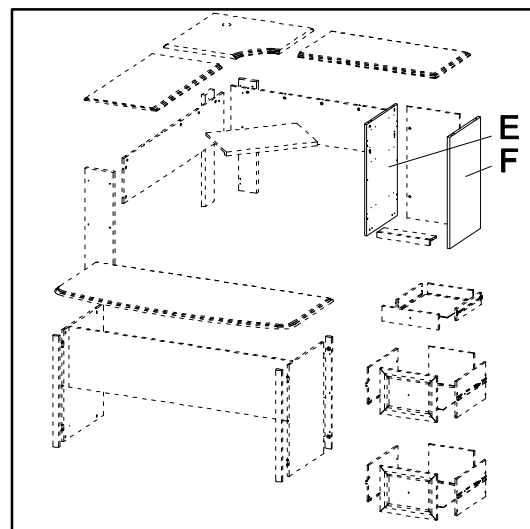

# STEP 7

S4

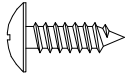

[2]

H1

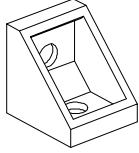

[2]

R1



[10]

M1

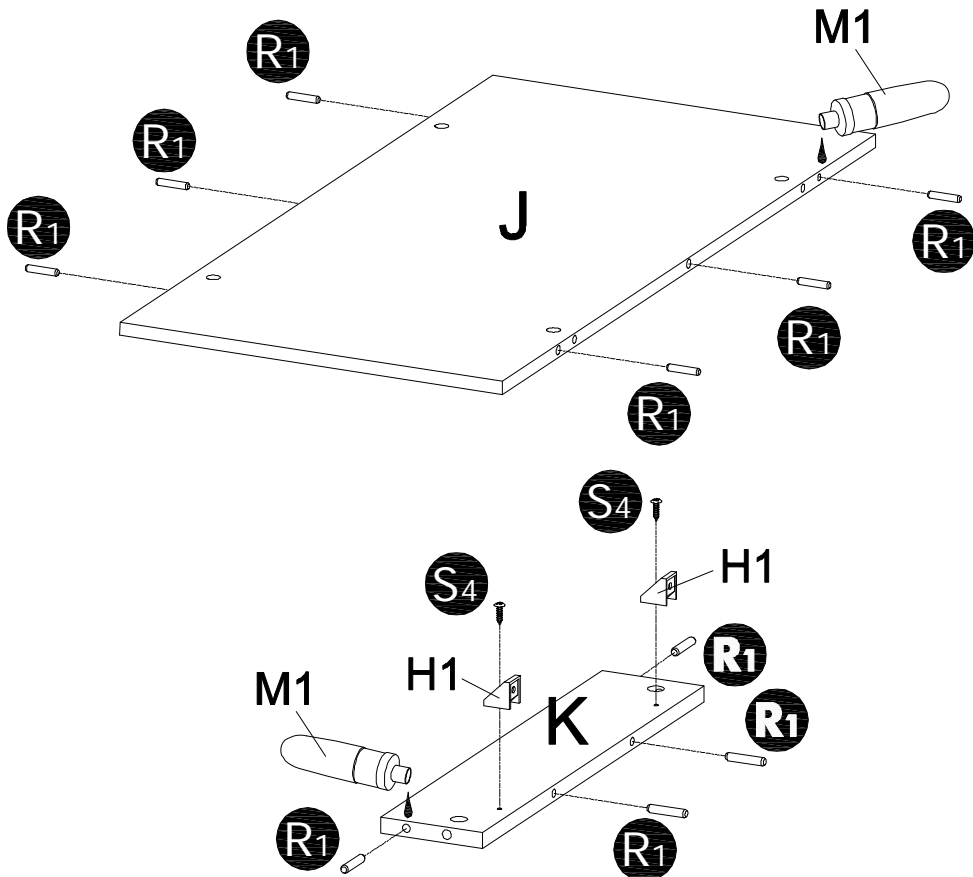
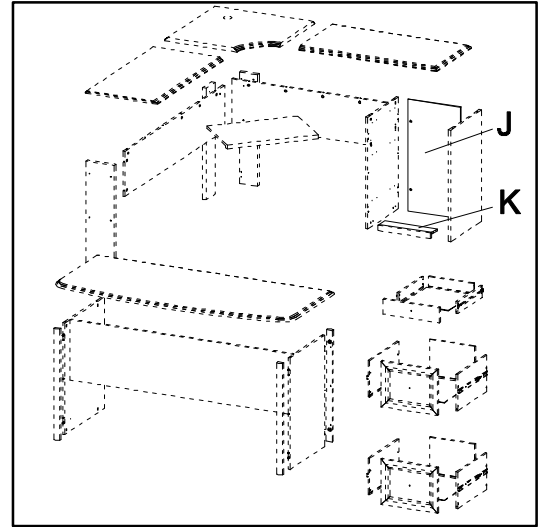
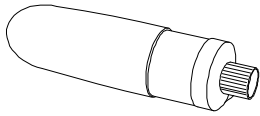



# STEP 8

S4

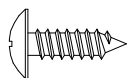

[2]

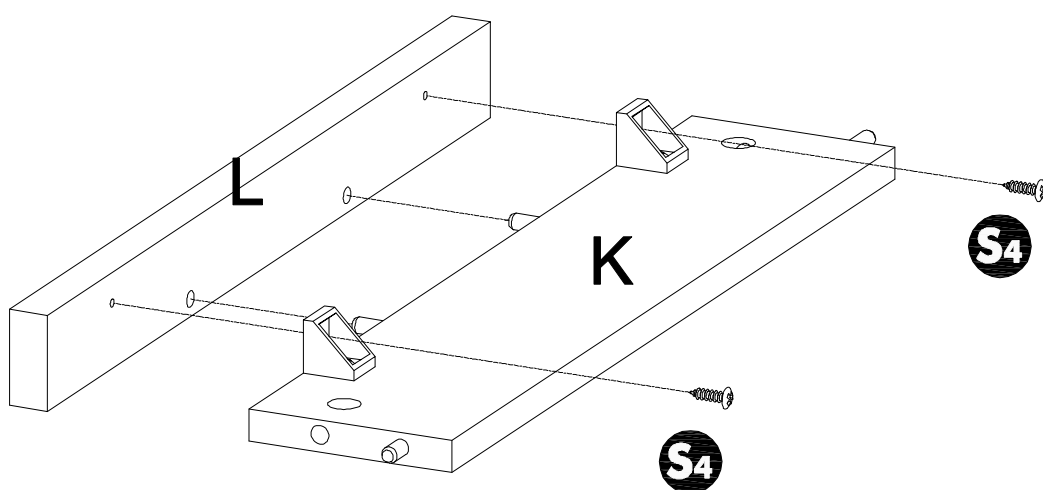
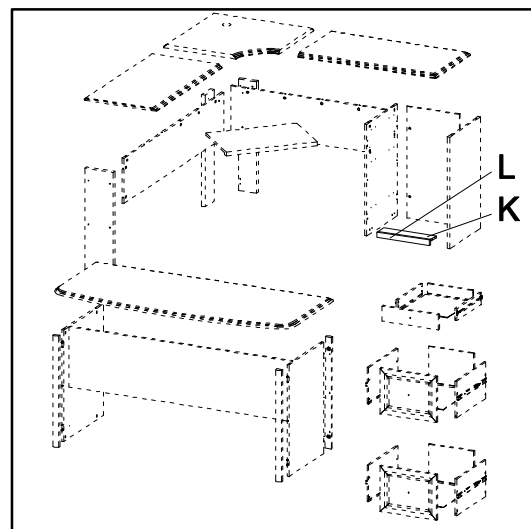

# STEP 9

N<sub>1</sub>



[ 3 ]

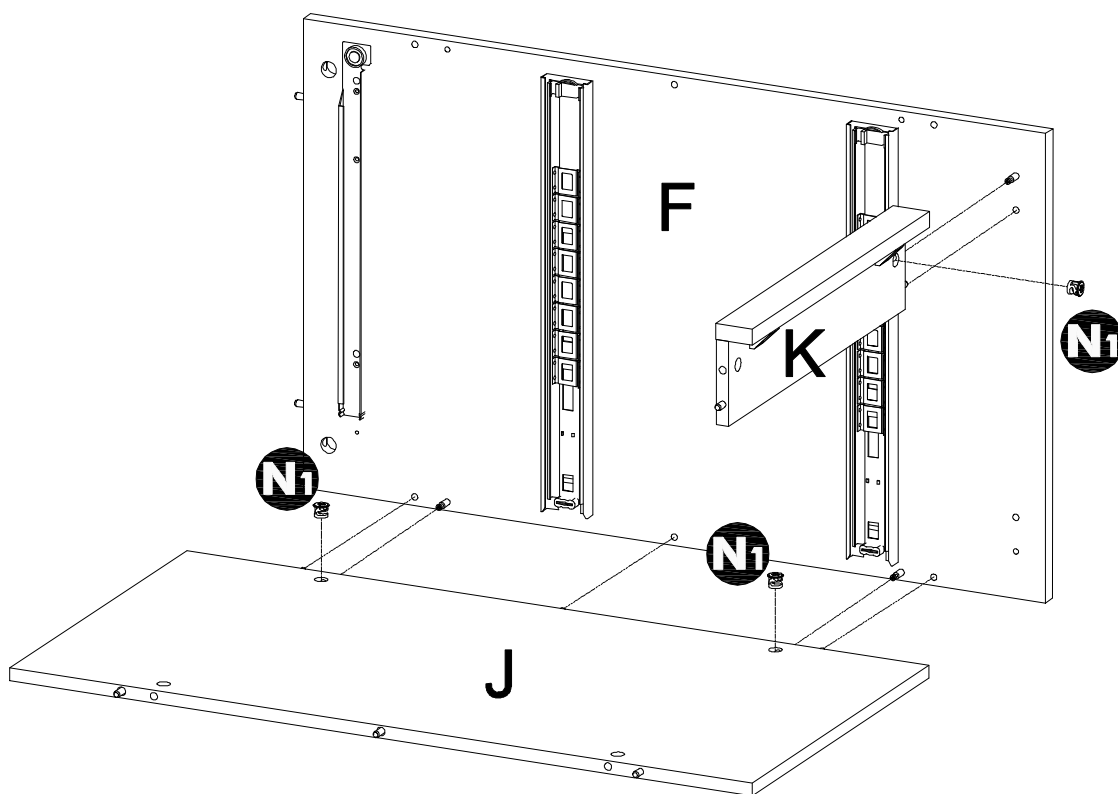
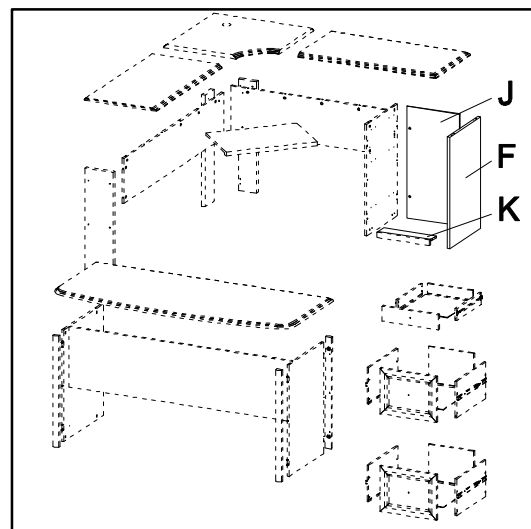

# STEP 10

N<sub>1</sub>

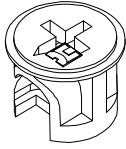

[ 3 ]

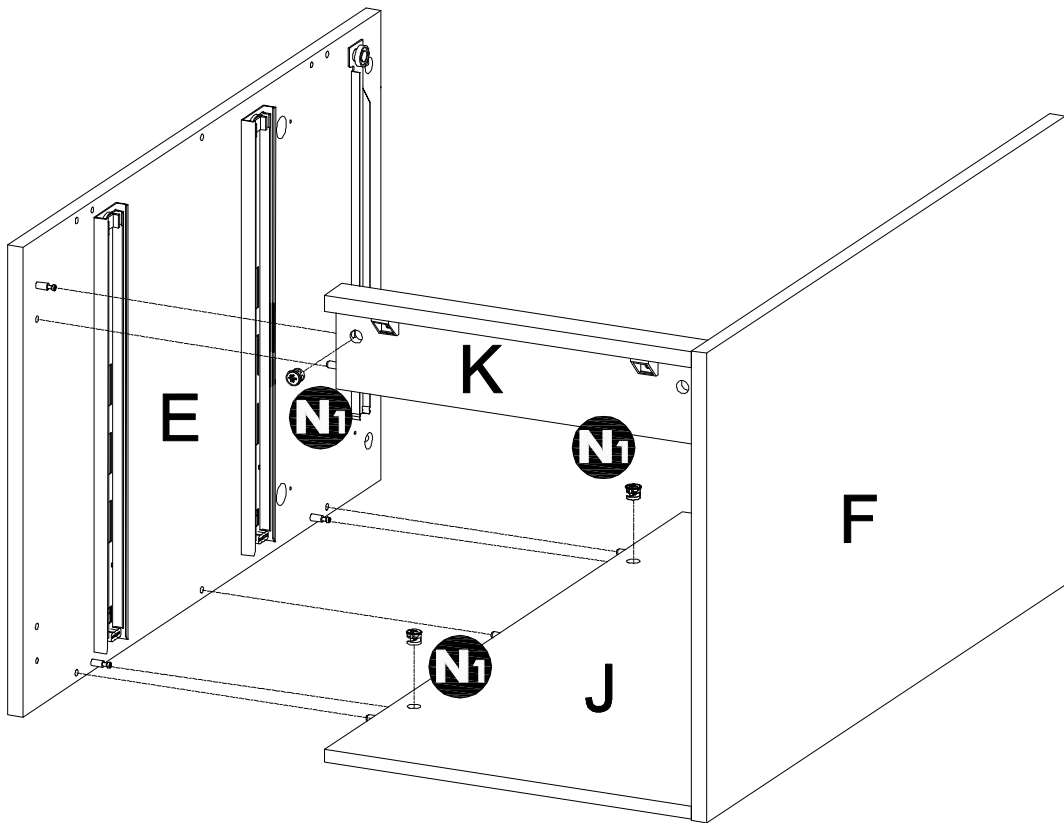
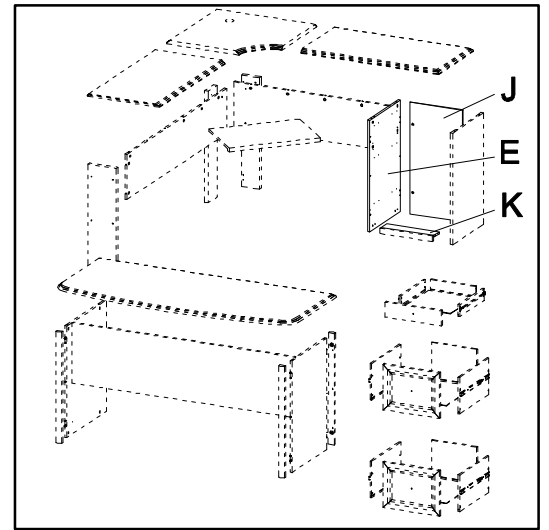

# STEP 11

G1



[ 4 ]

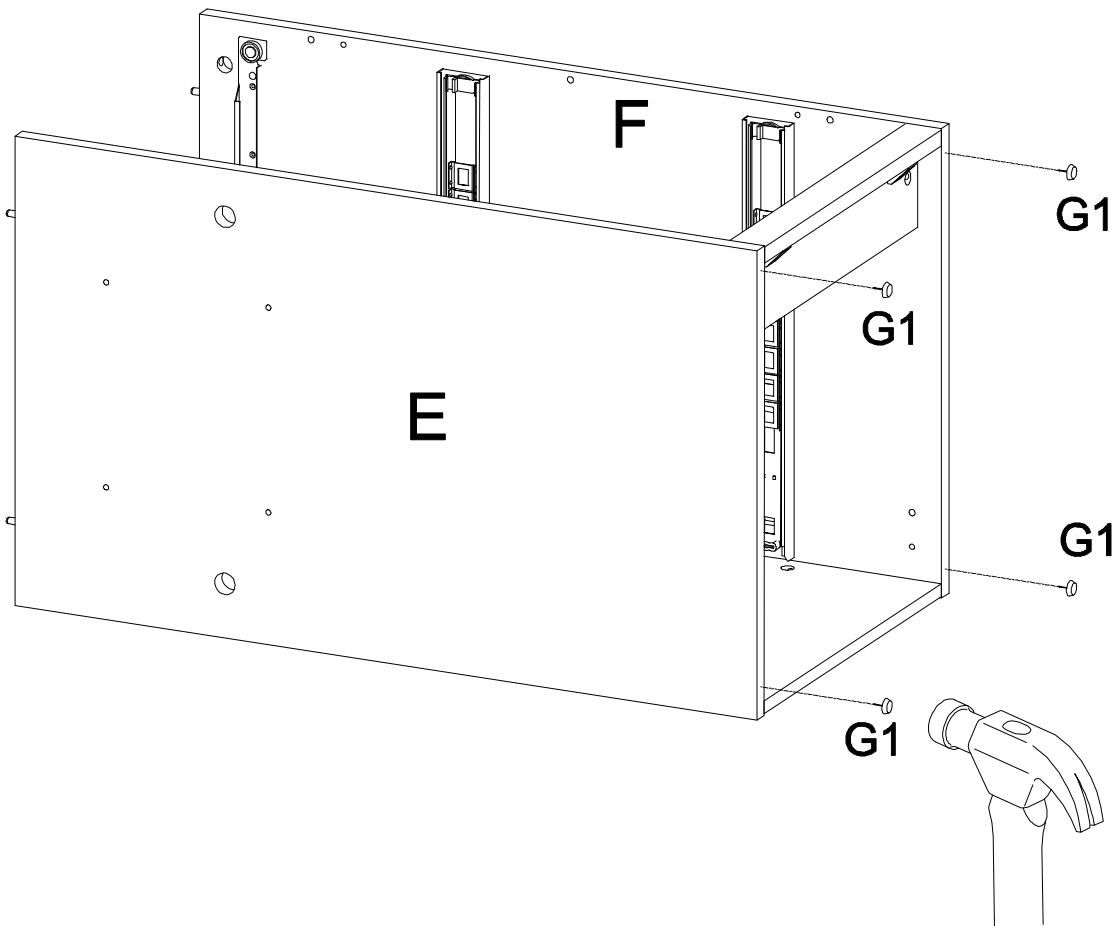
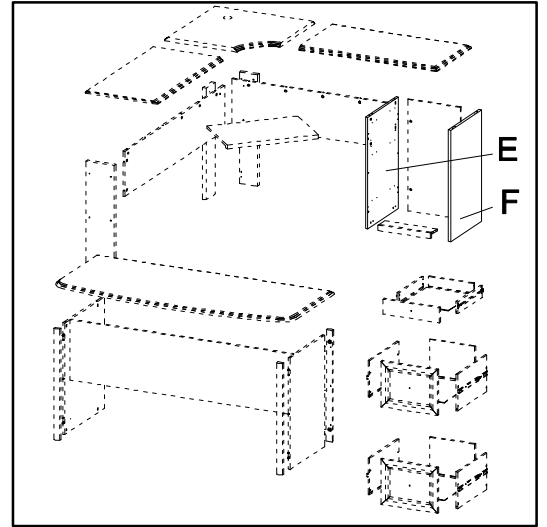

# STEP 12



Q1

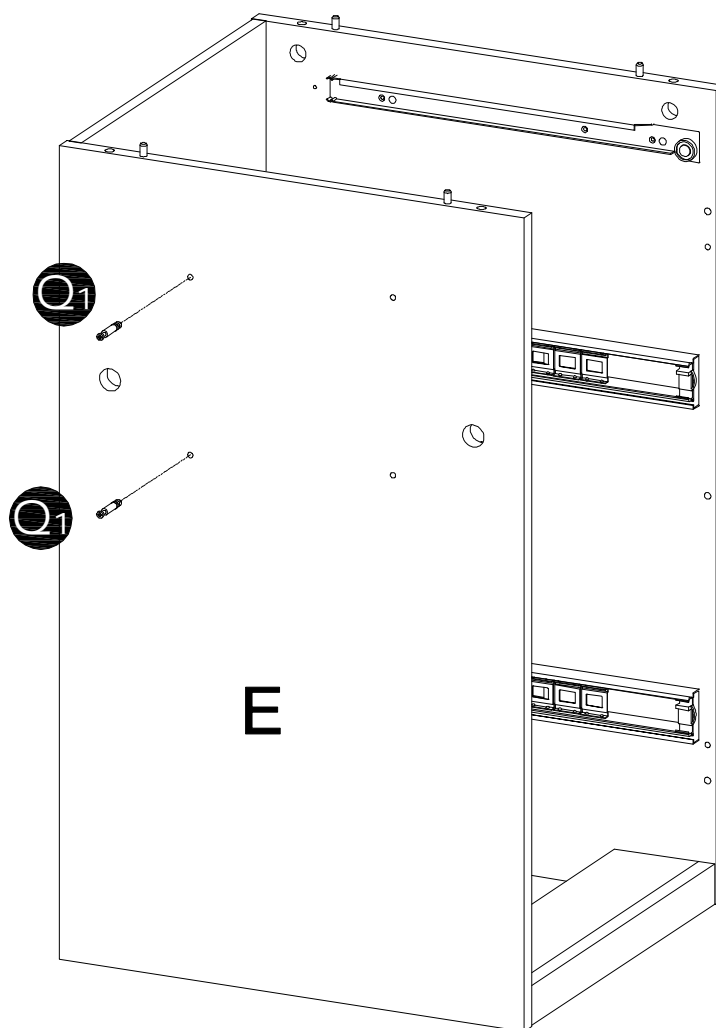
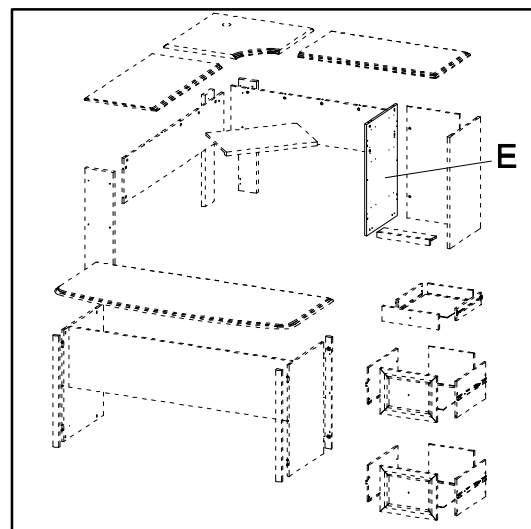

[ 2 ]

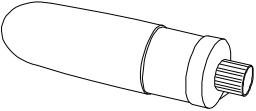

# STEP 13

- G1**  [4]
- Q1**  [2]
- R1**  [4]
- M1** 

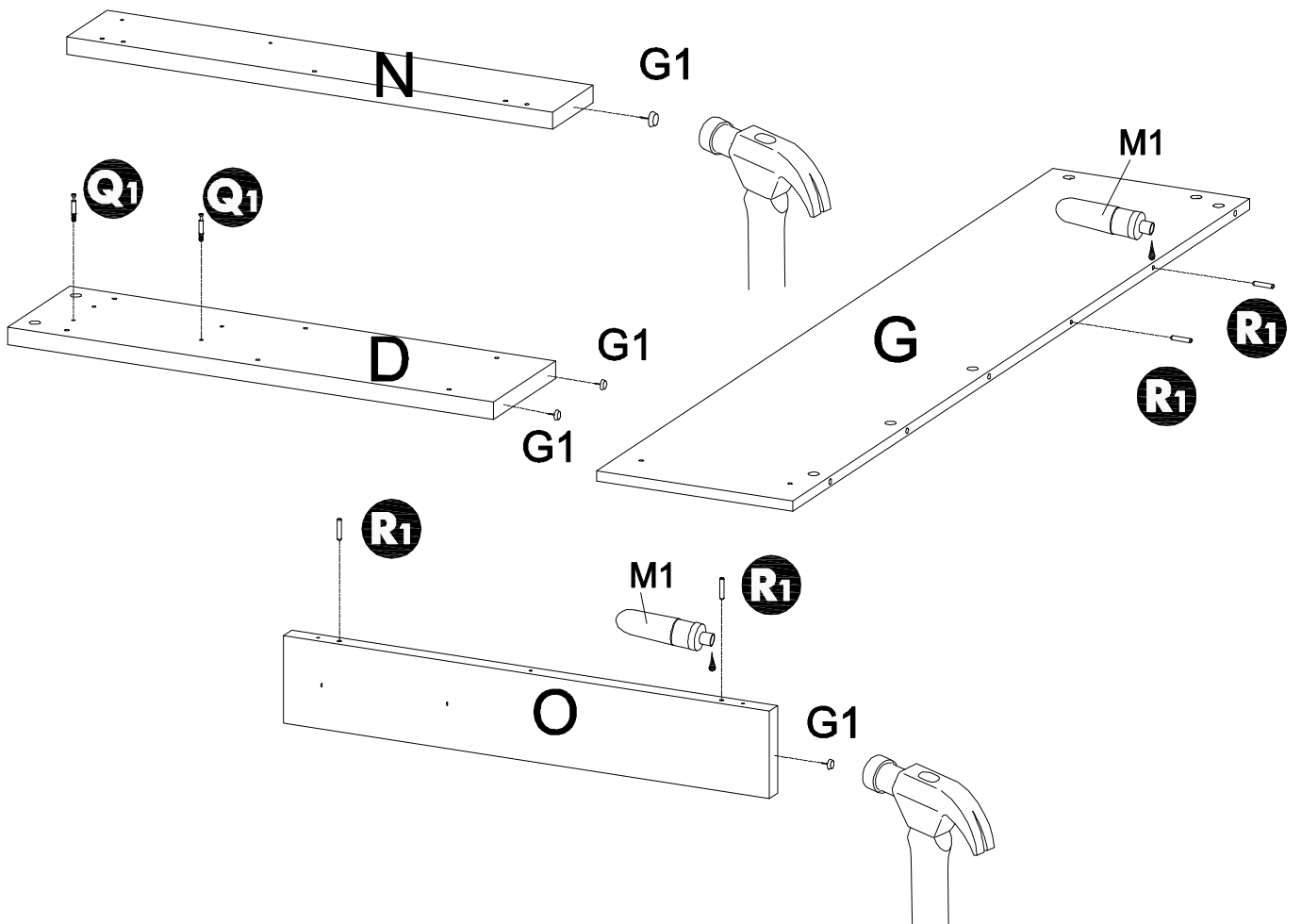
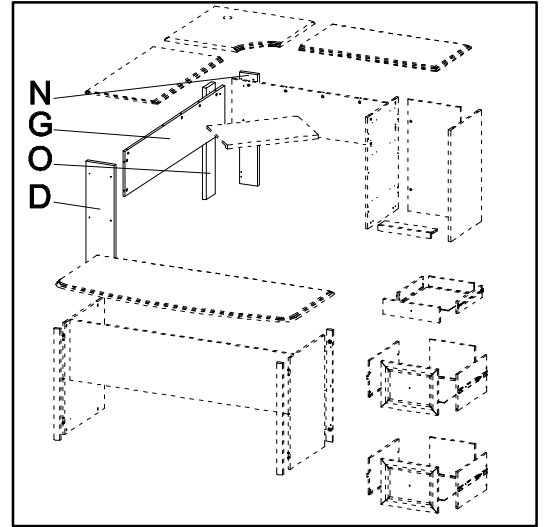

# STEP 14

S<sub>2</sub>

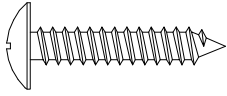

[ 2 ]

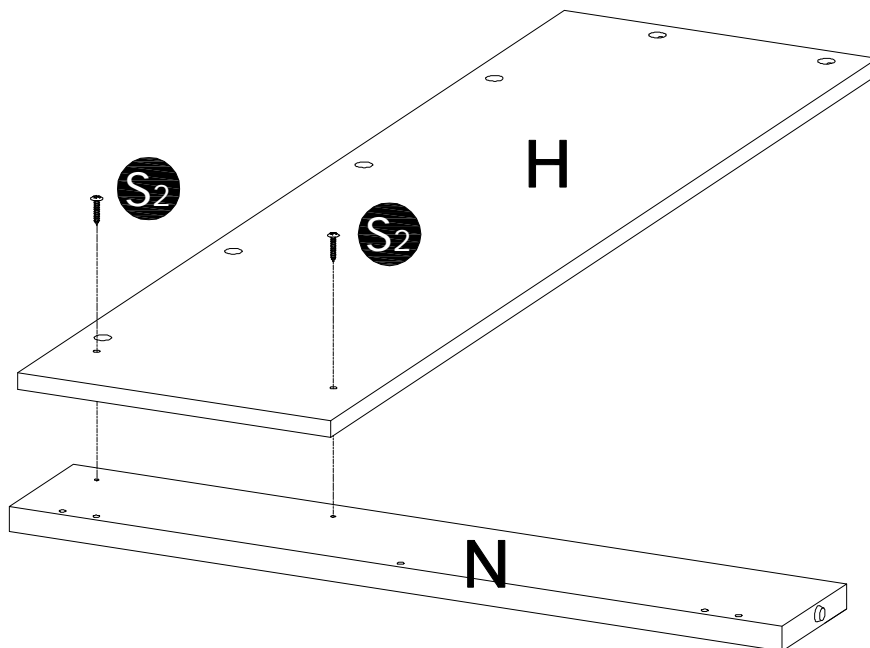
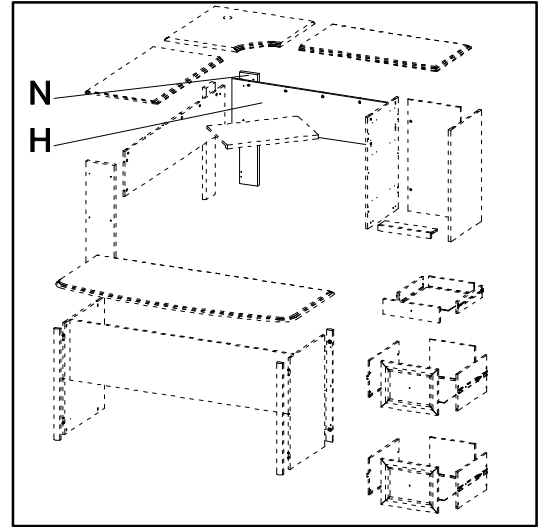

# STEP 15

P<sub>1</sub>

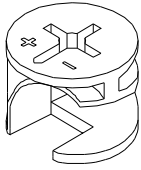

[2]

F<sub>1</sub>

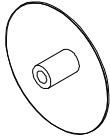

[2]

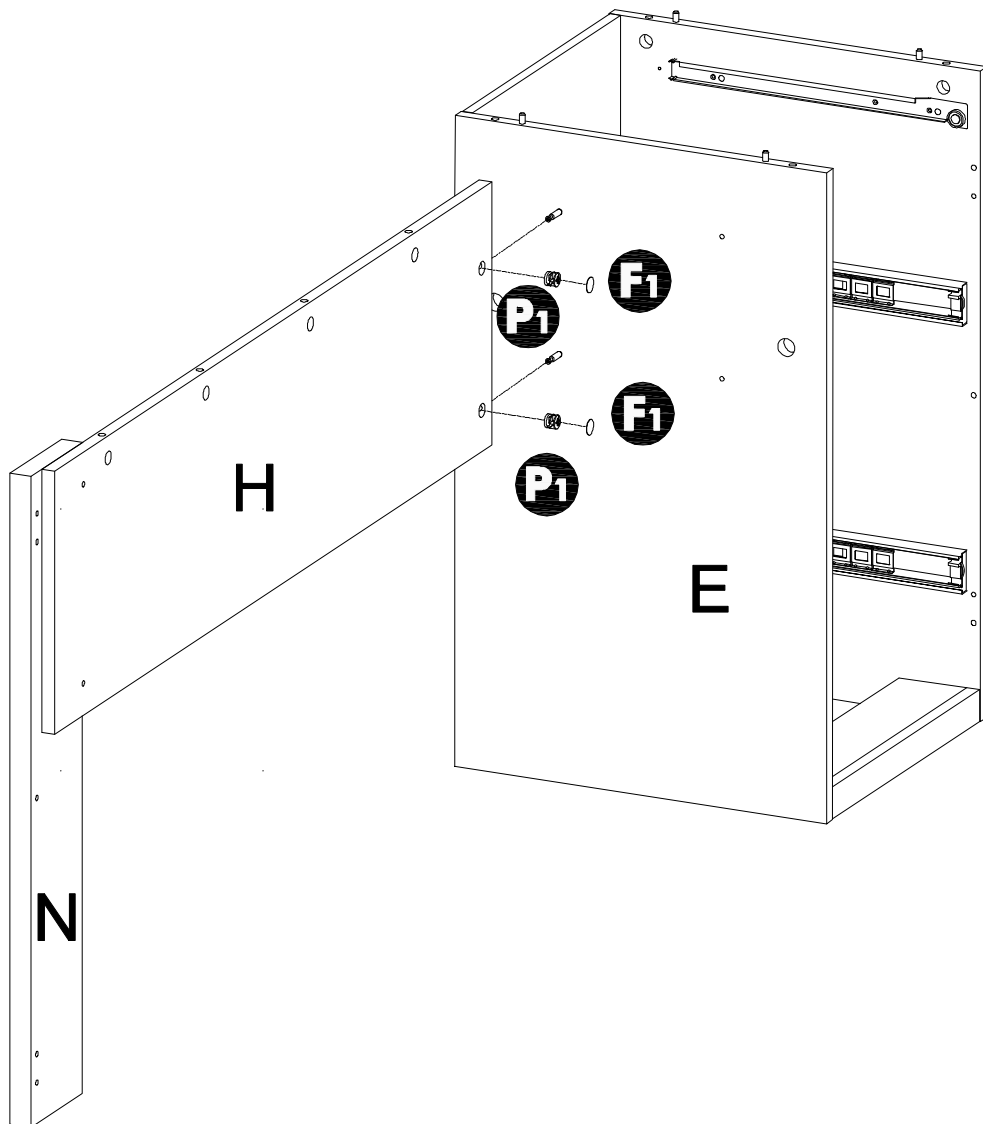
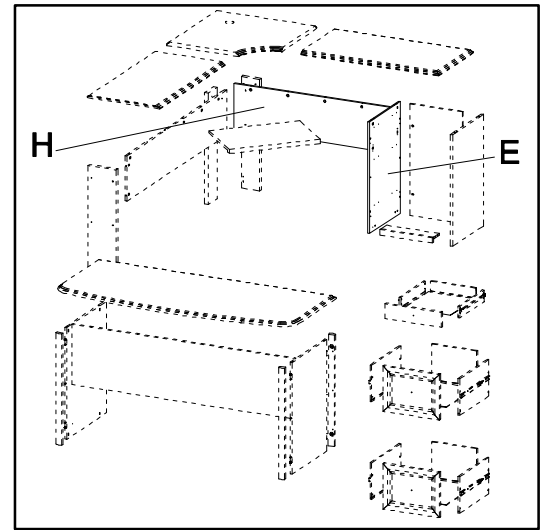



# STEP 16

S<sub>2</sub>

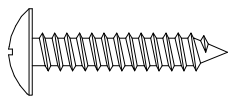

[2]

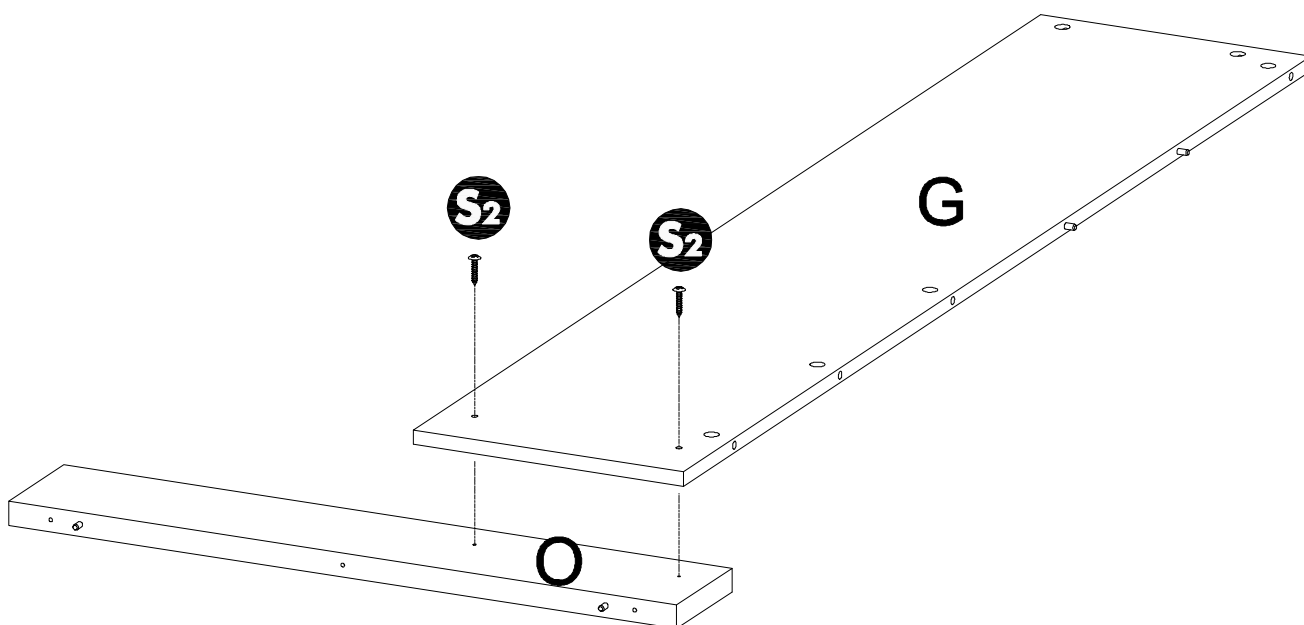
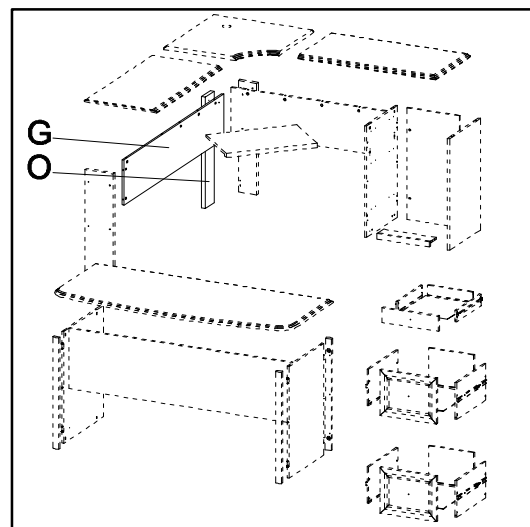

# STEP 17

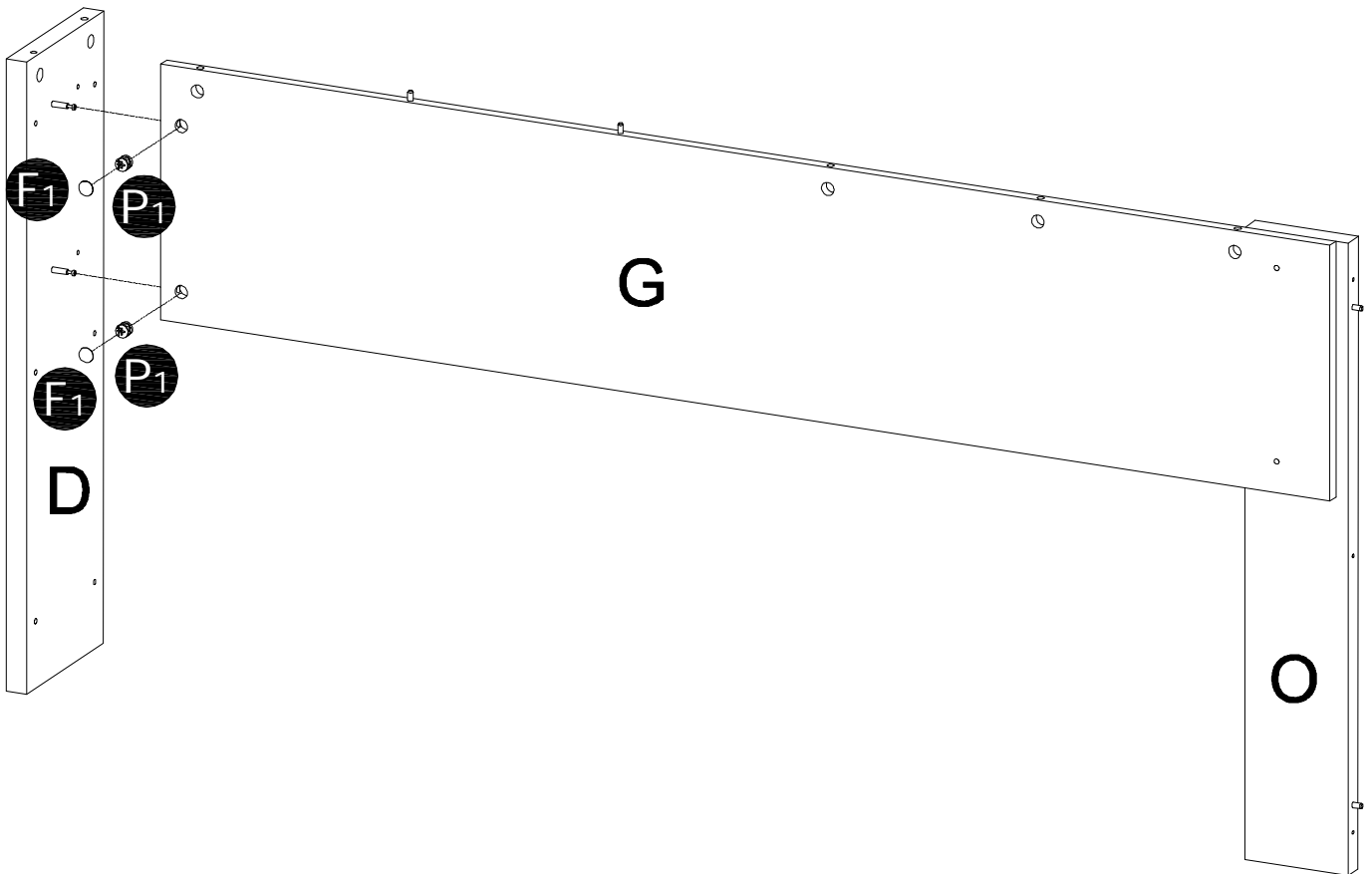
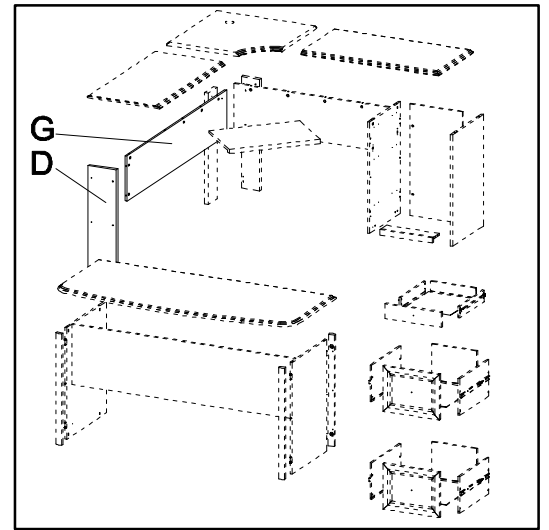
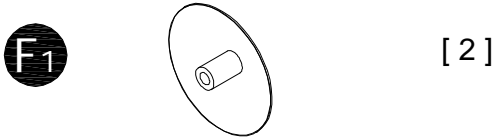
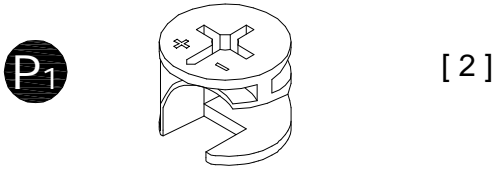

# STEP 18

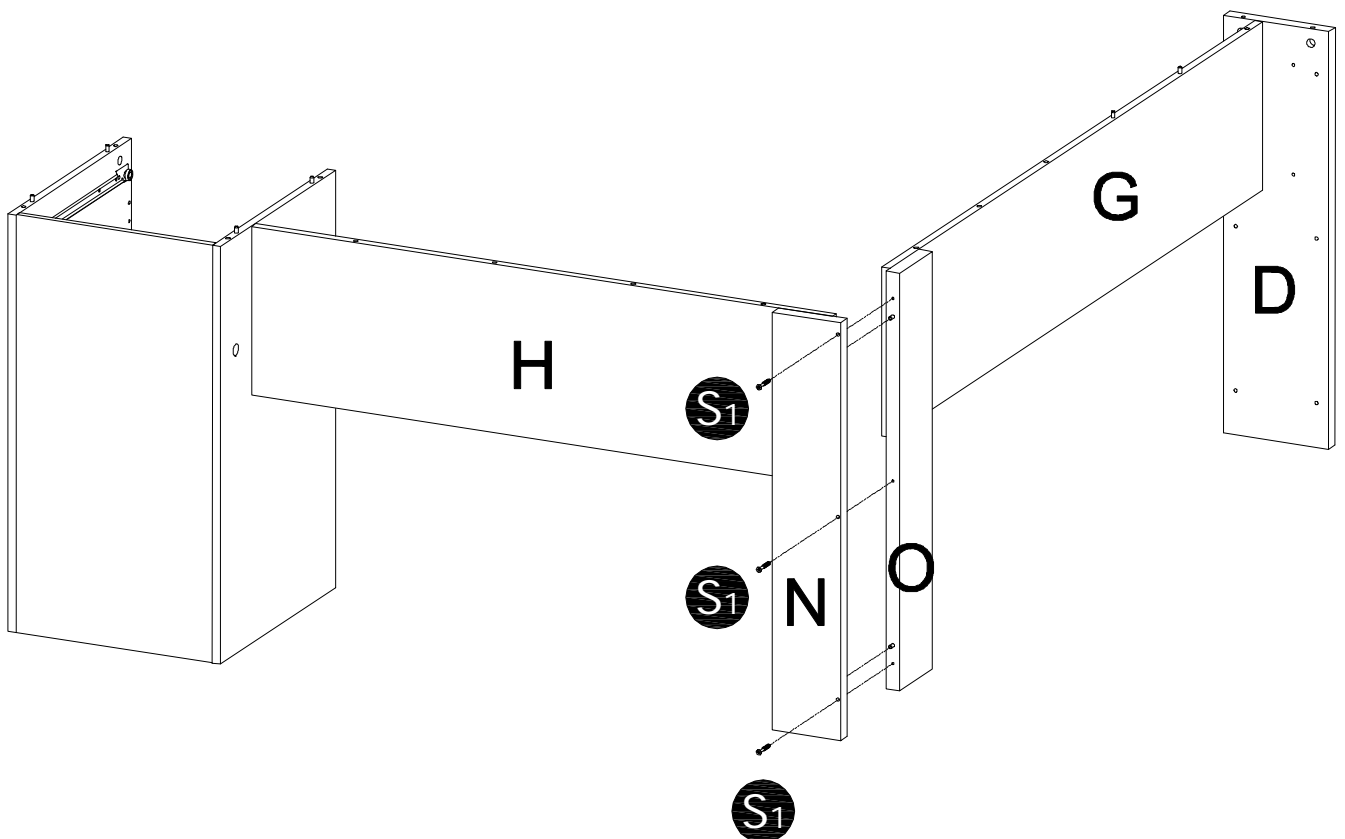
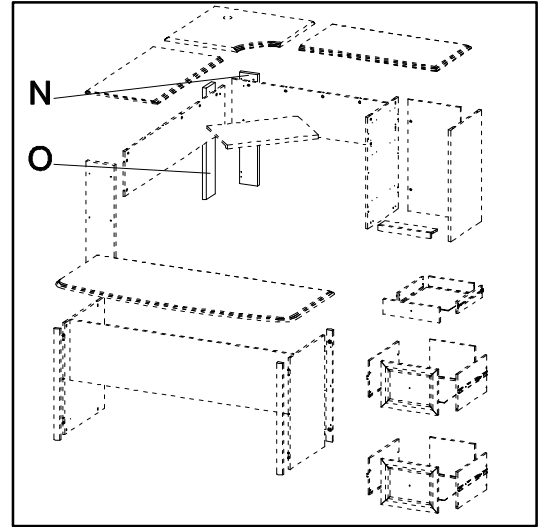
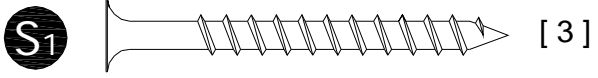

# STEP 19

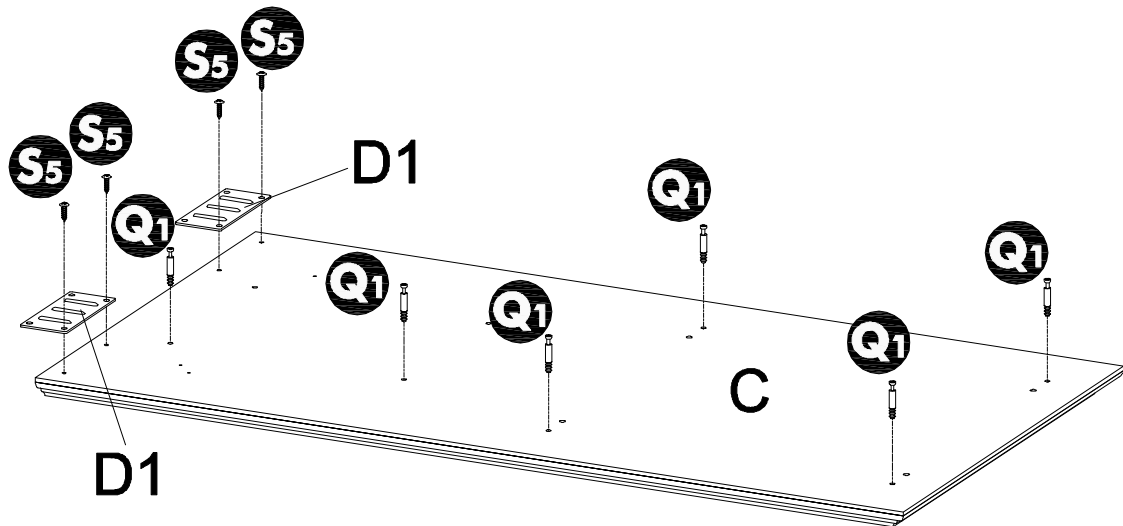
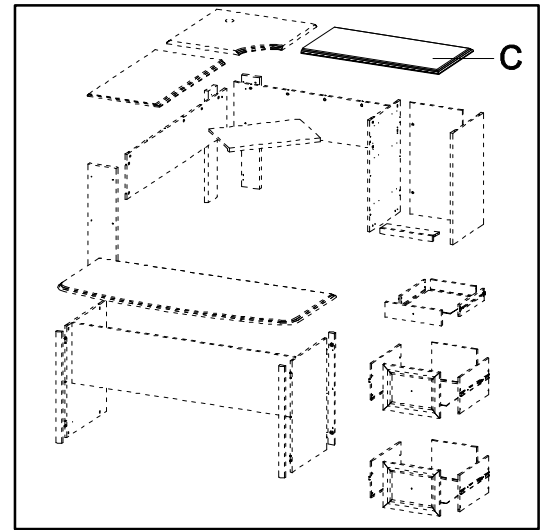
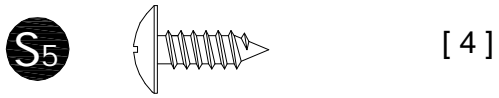
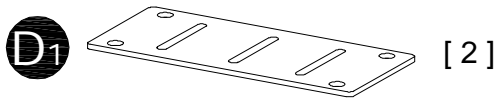

# STEP 20

P<sub>1</sub>

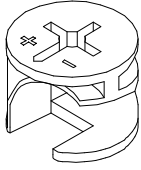

[6]

F<sub>1</sub>

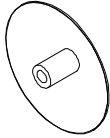

[2]

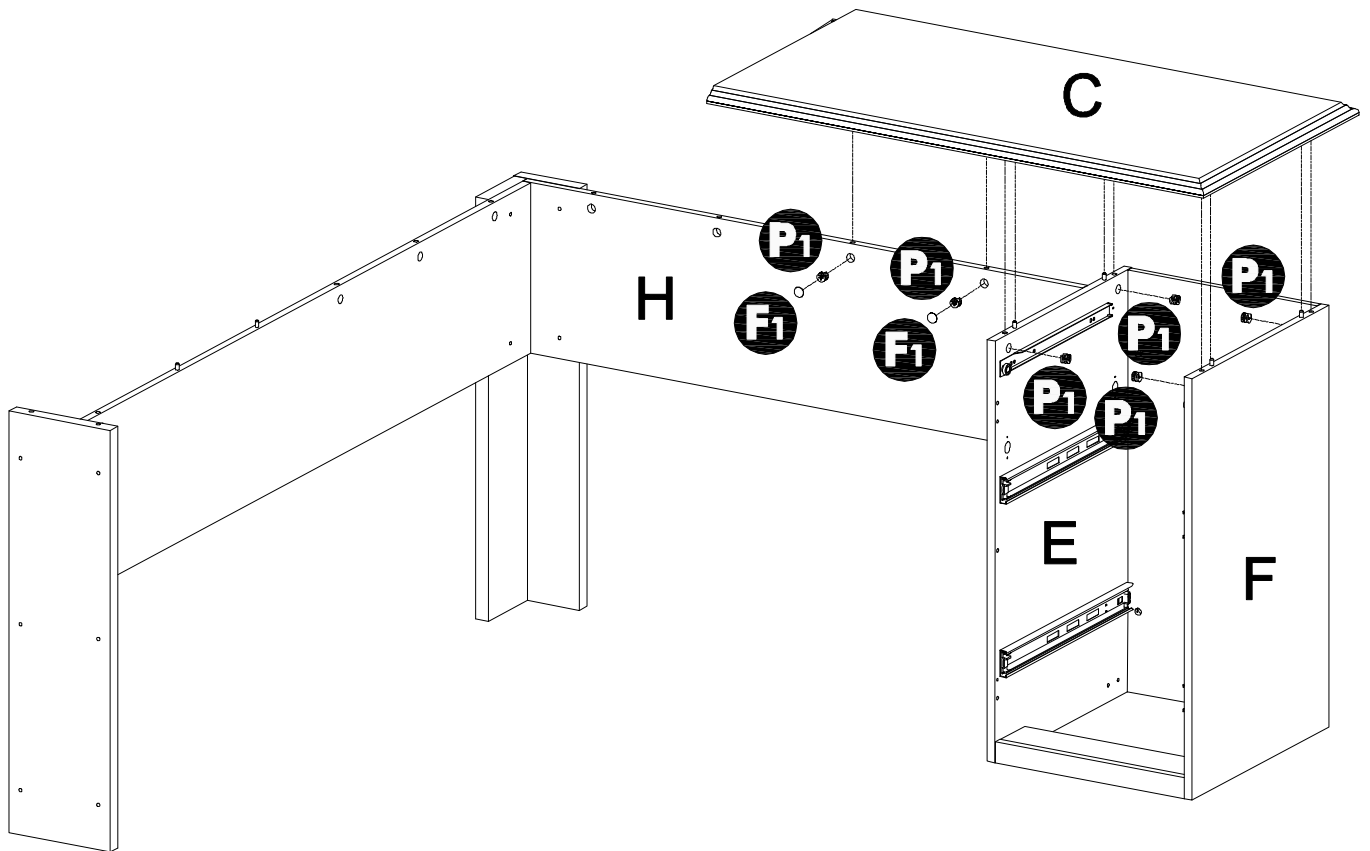
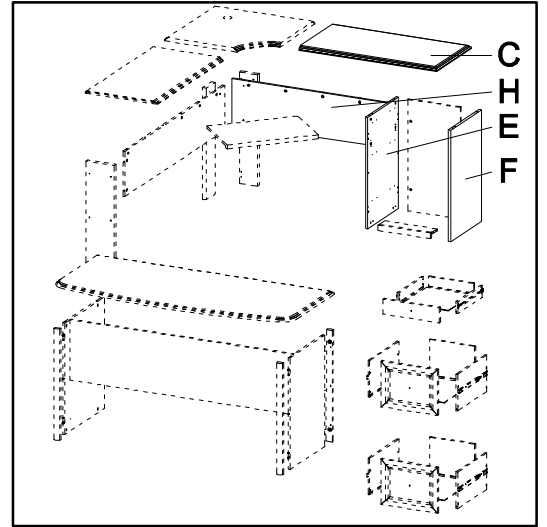

# STEP 21

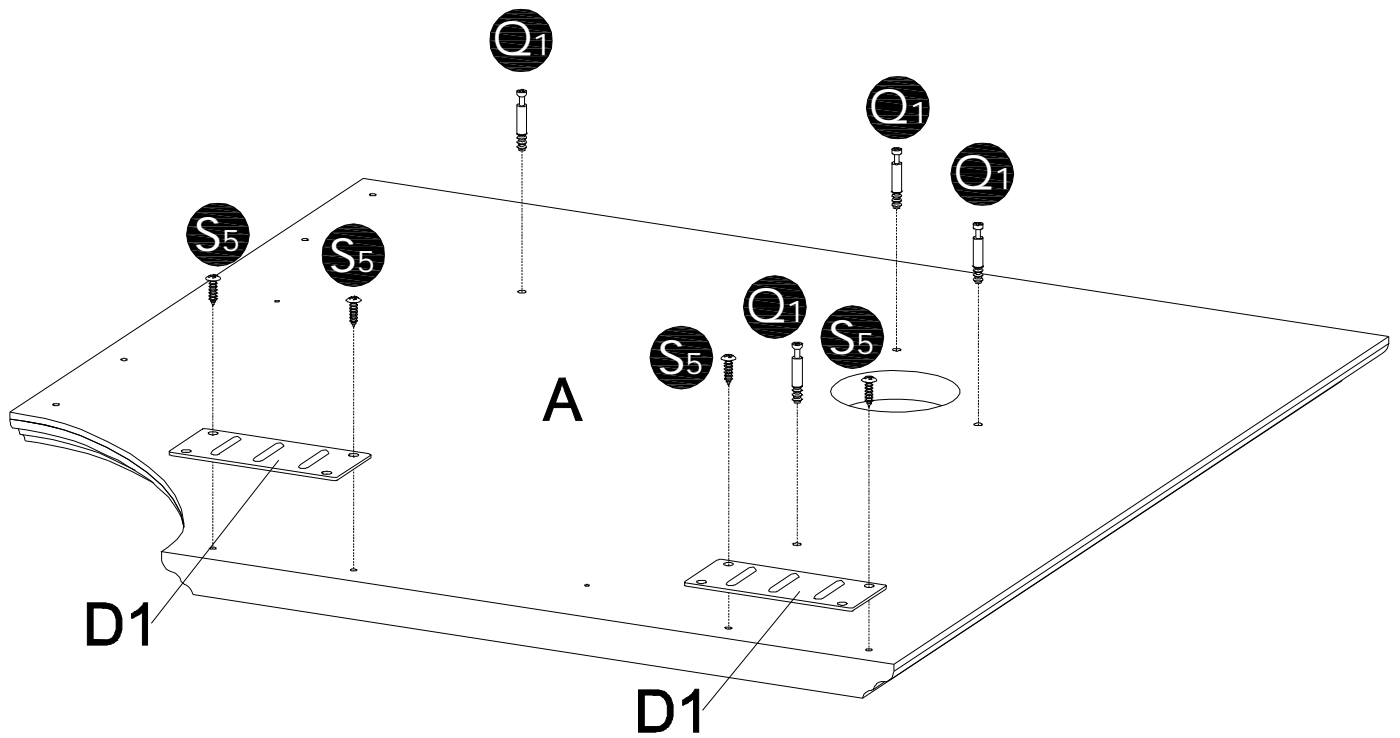
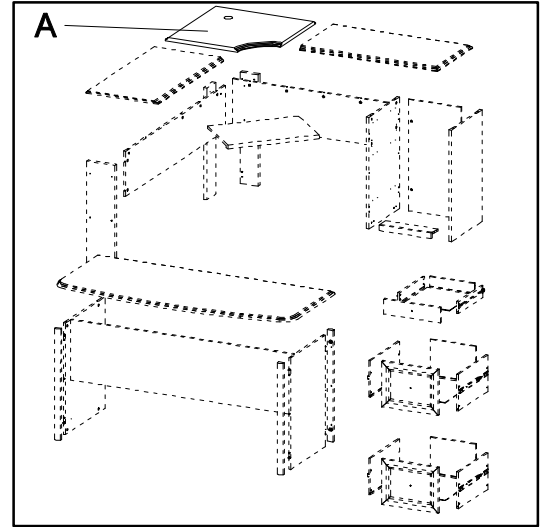
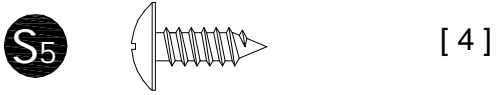
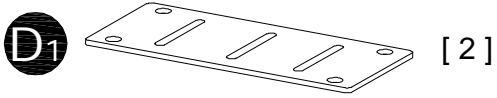
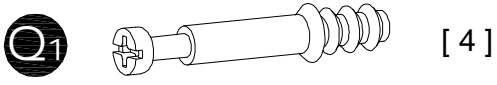

# STEP 22

P<sub>1</sub>

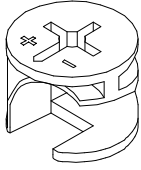

[ 4 ]

F<sub>1</sub>

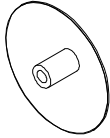

[ 4 ]

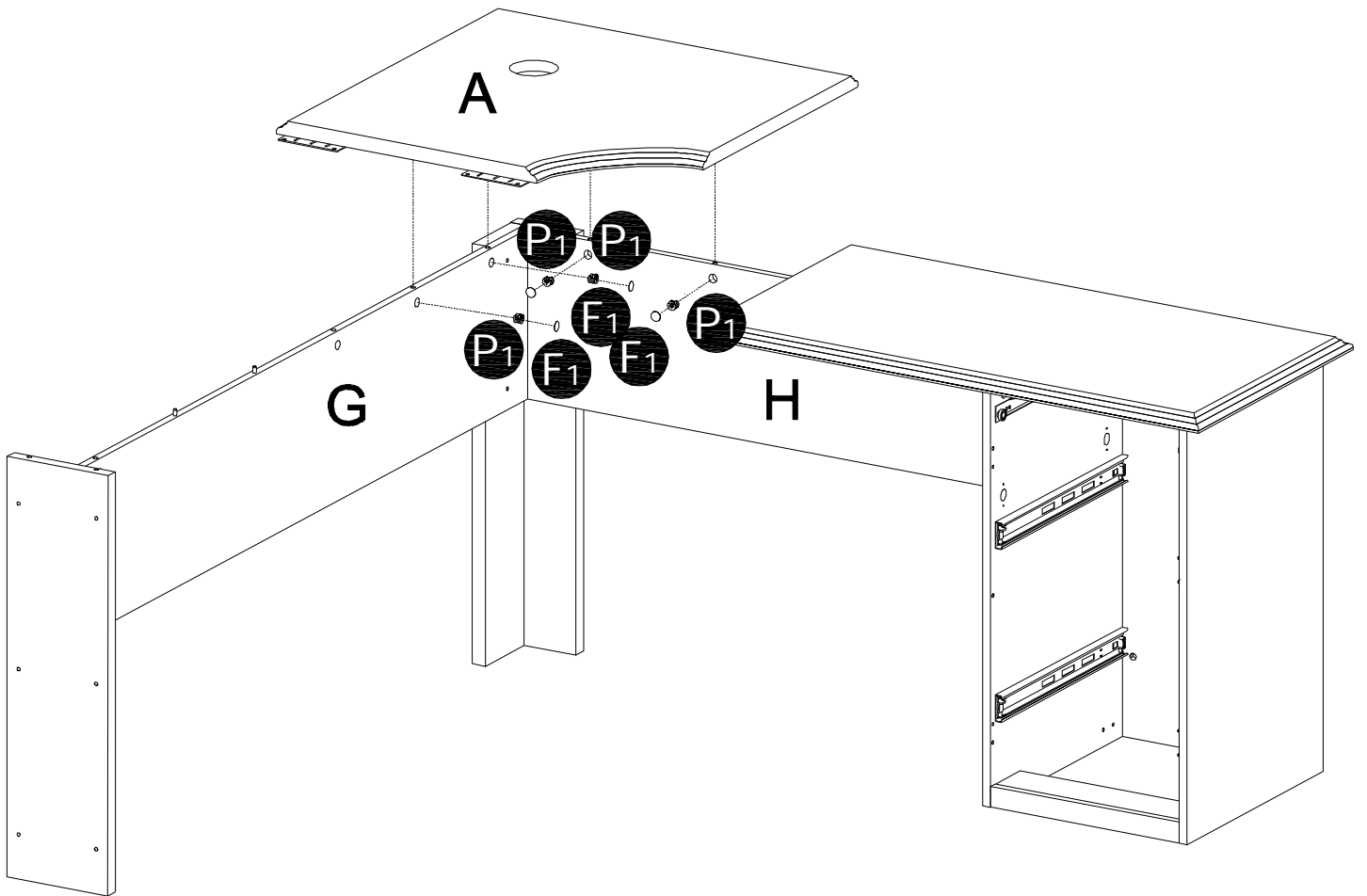
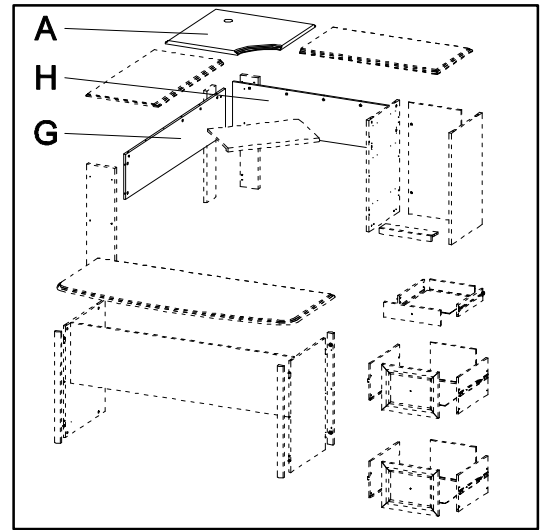

# STEP 23

S5

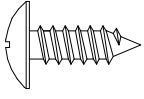

[ 4 ]

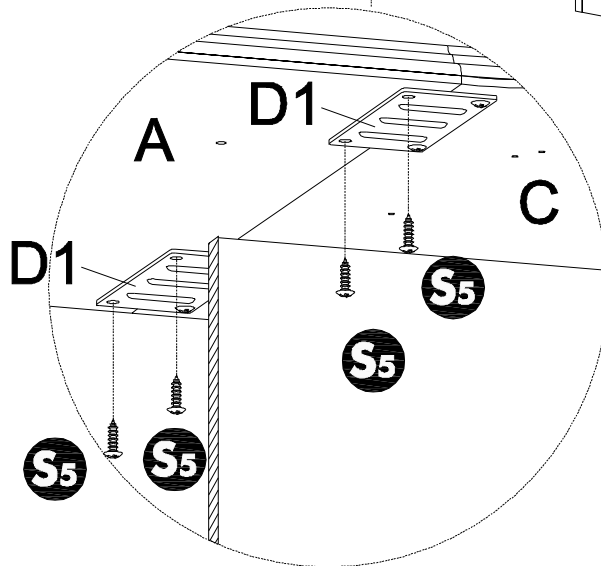
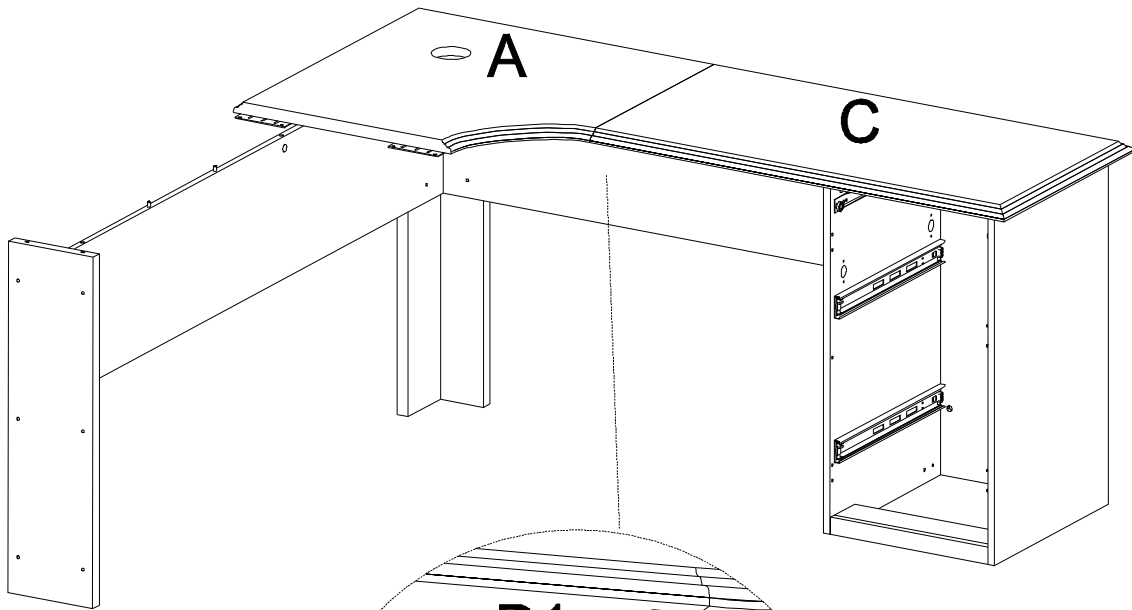
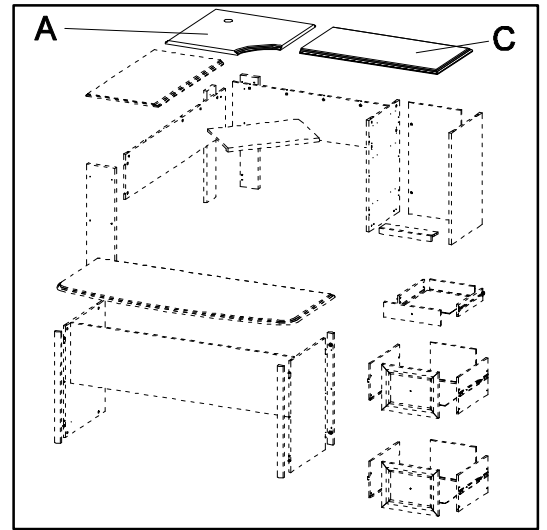



# STEP 24

Q1



[ 4 ]

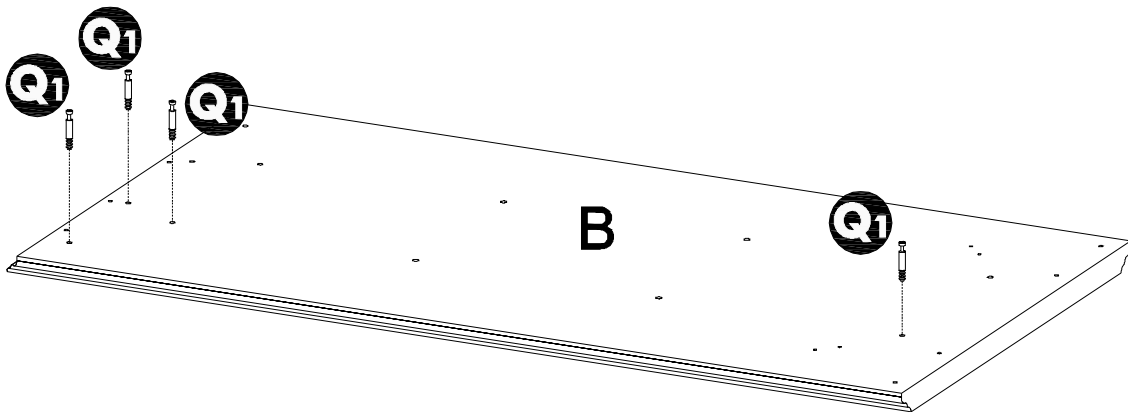
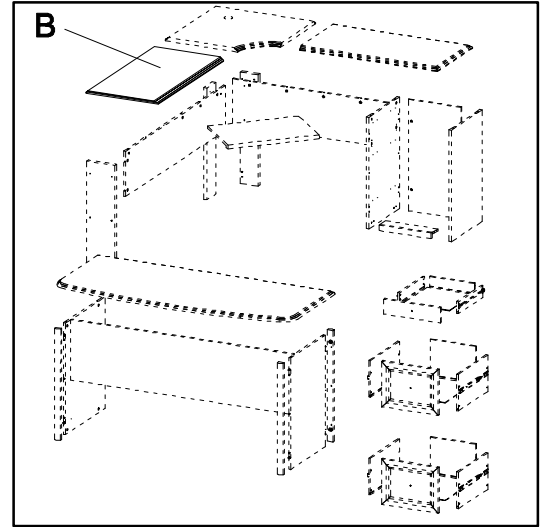

# STEP 25

P<sub>1</sub>

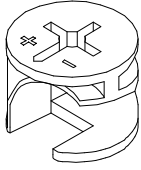

[ 4 ]

F<sub>1</sub>

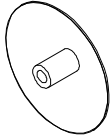

[ 4 ]

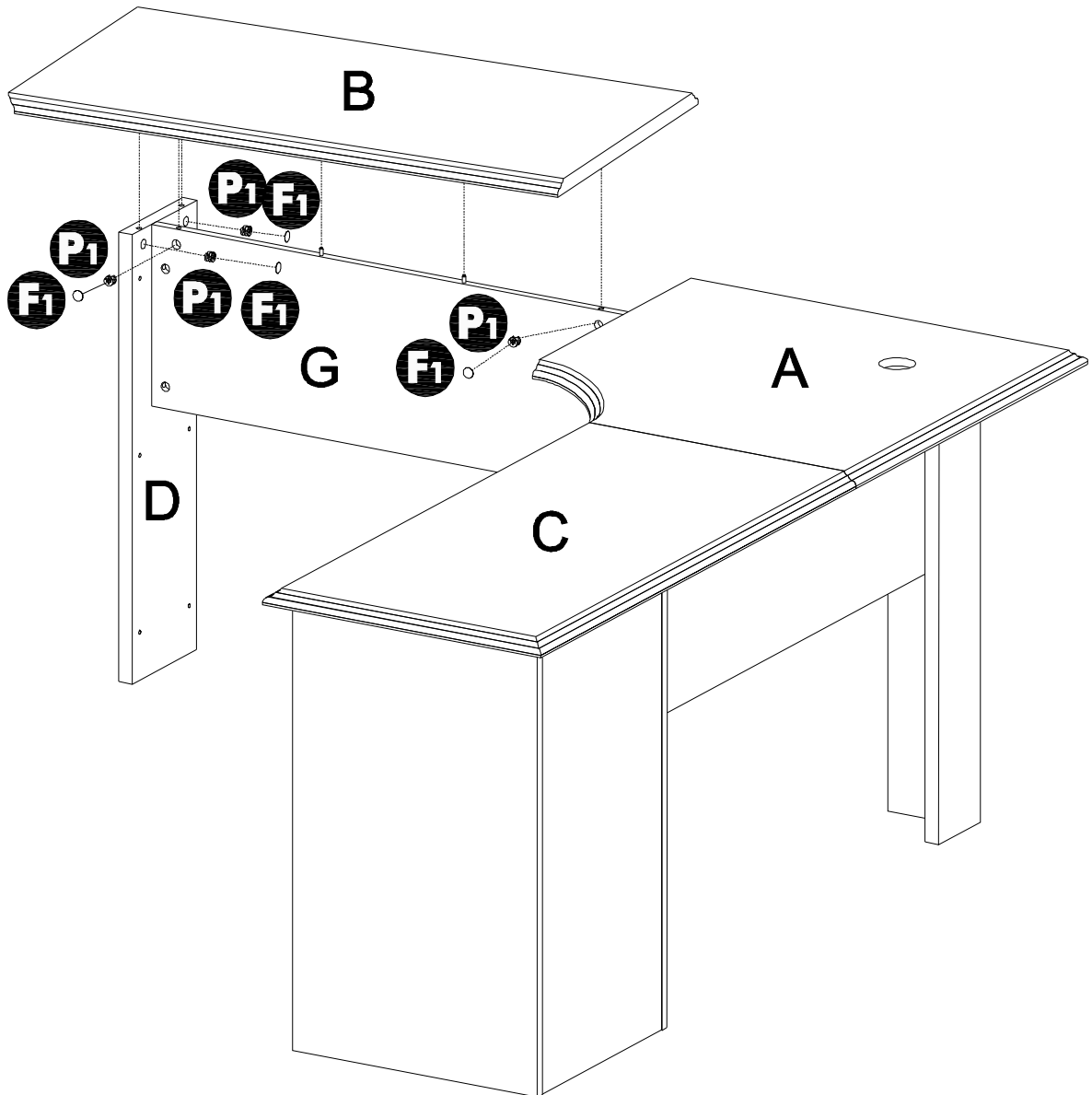
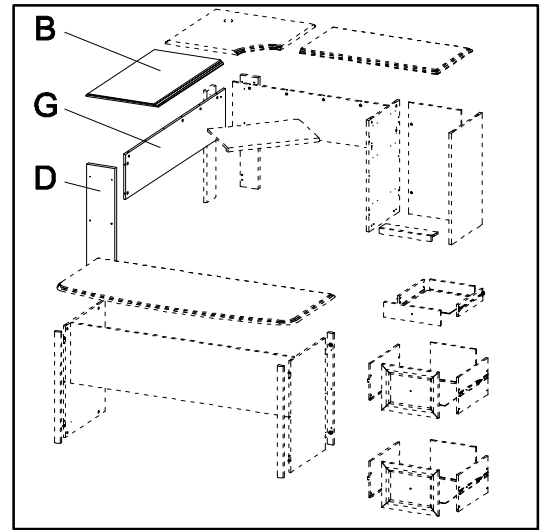

# STEP 26

S5

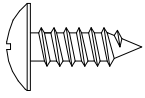

[ 4 ]

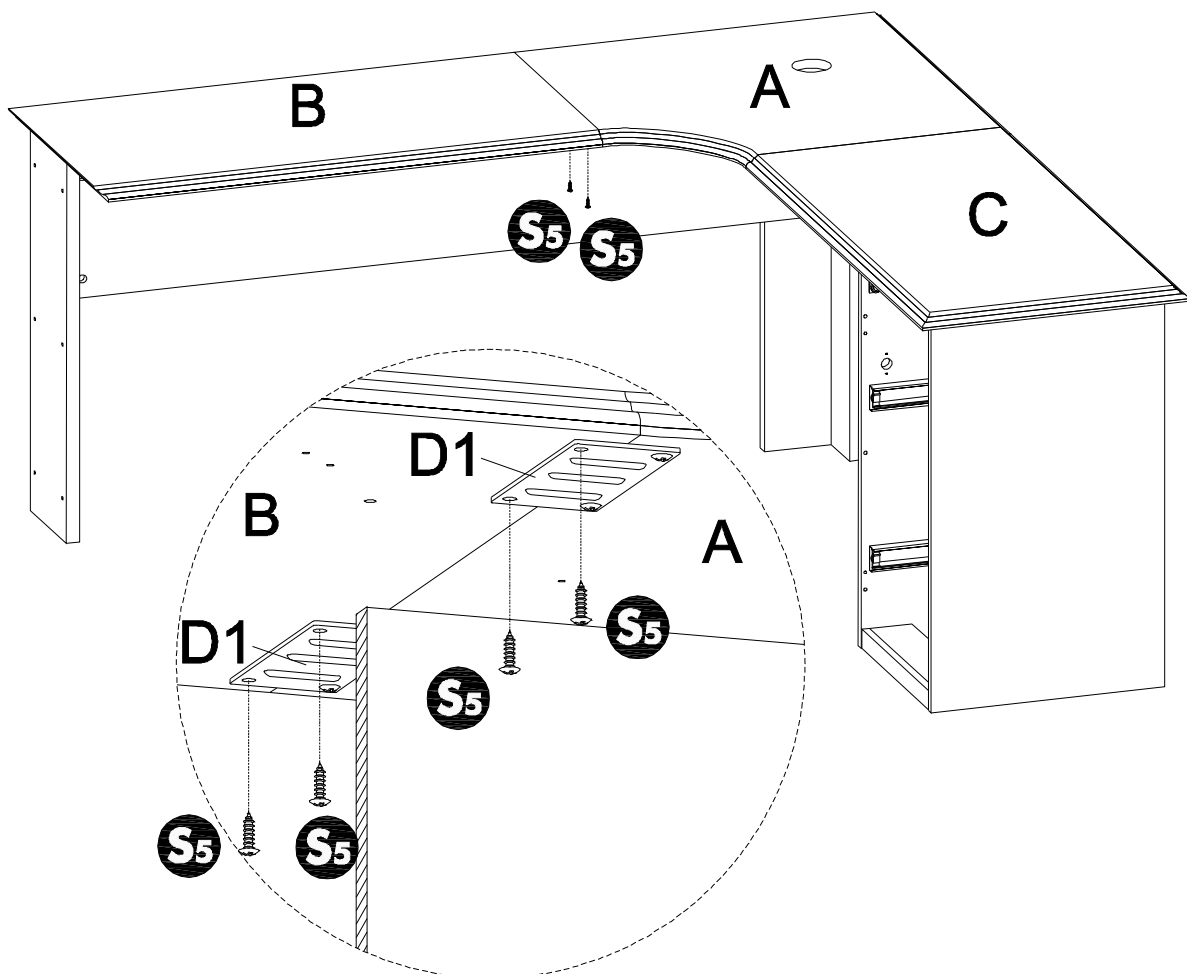
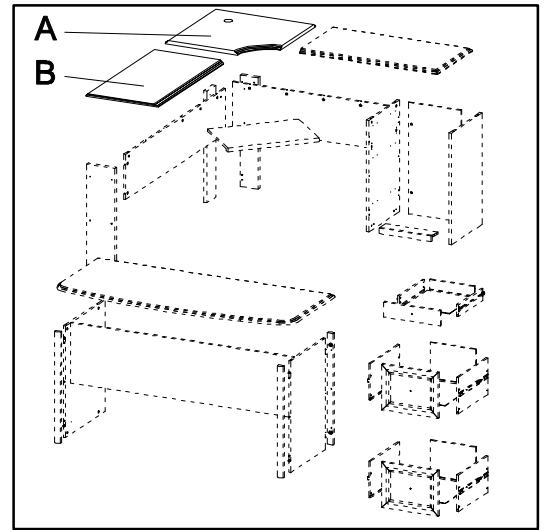

# STEP 27

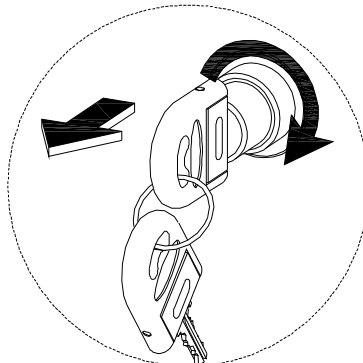
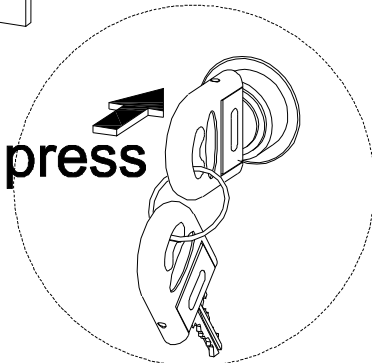
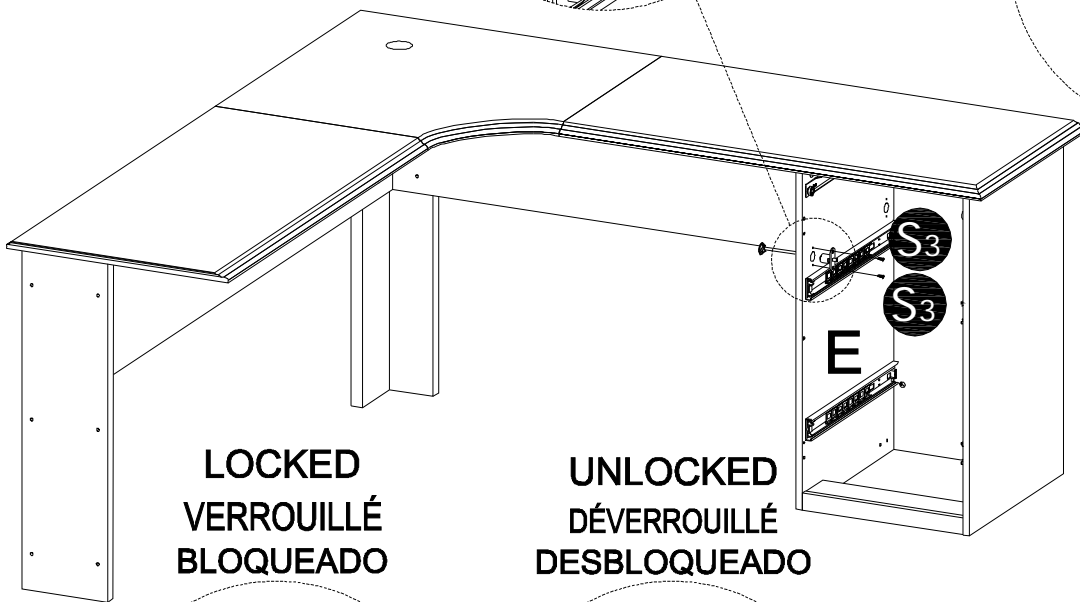
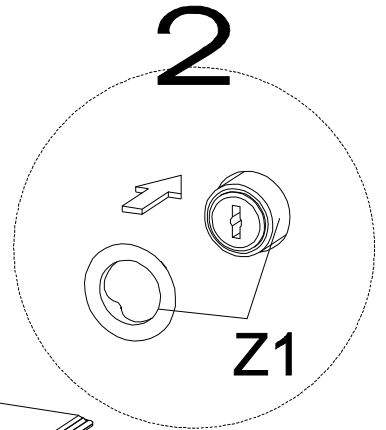
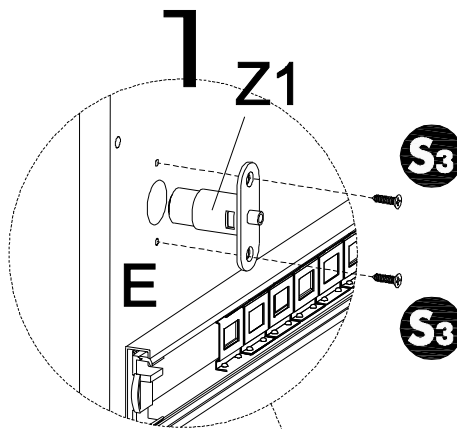
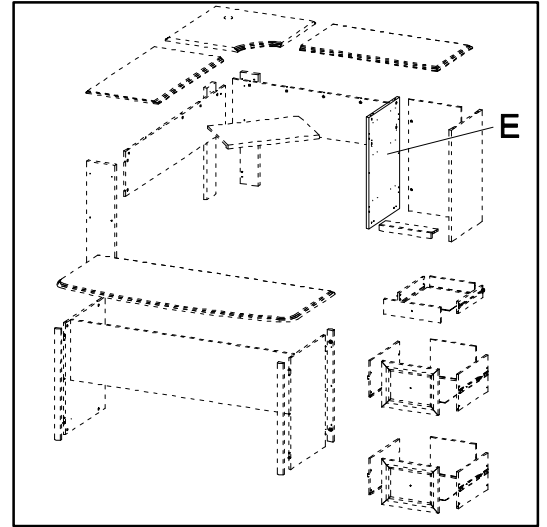
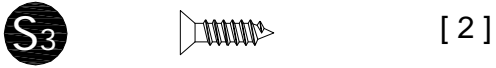
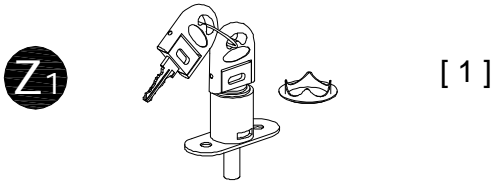

# STEP 28

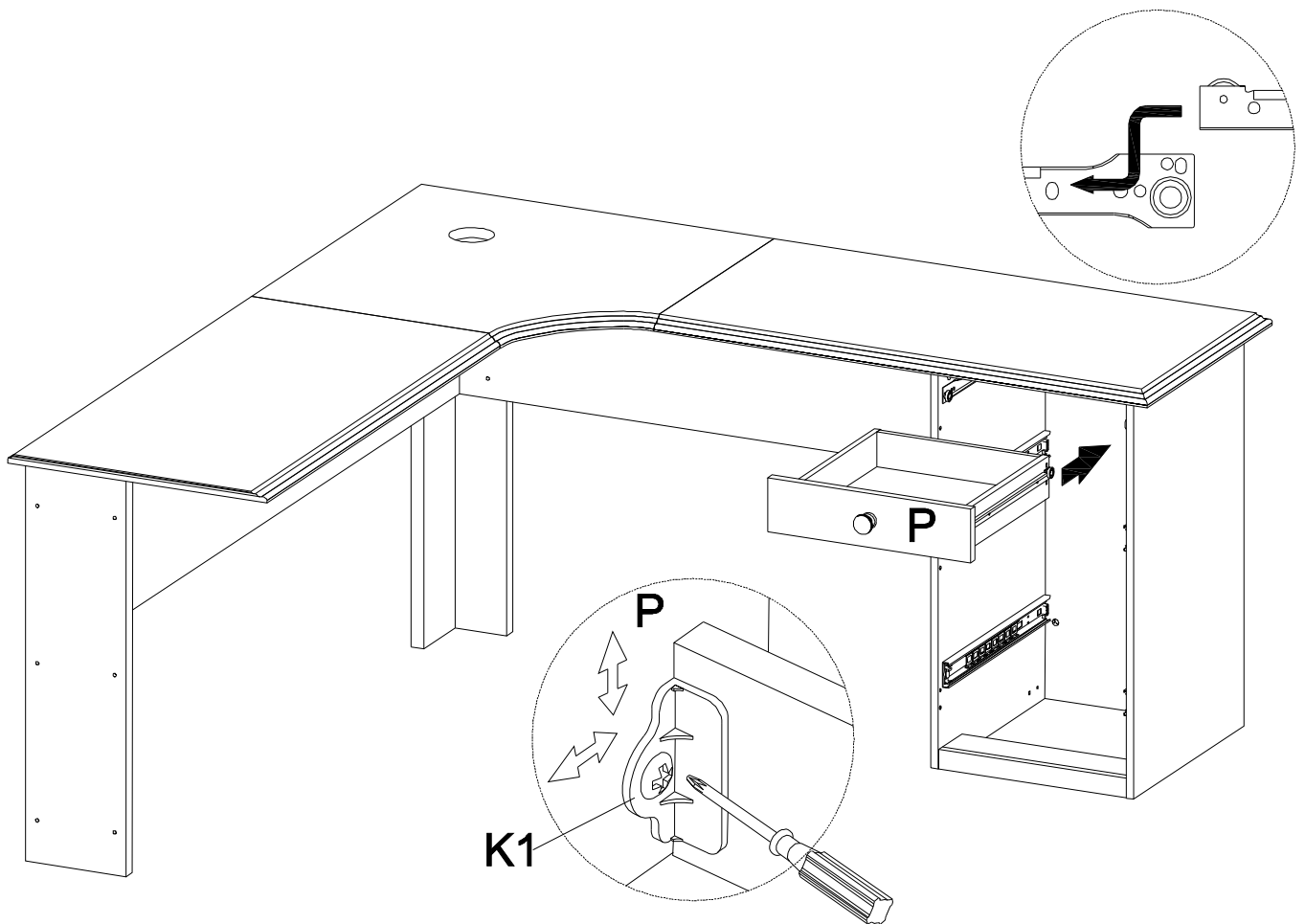
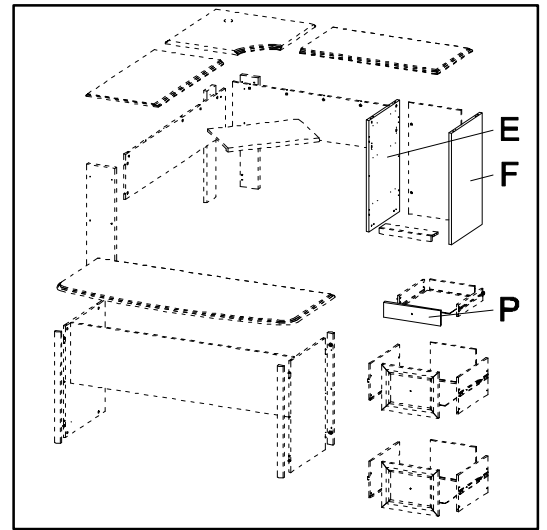

# STEP 29

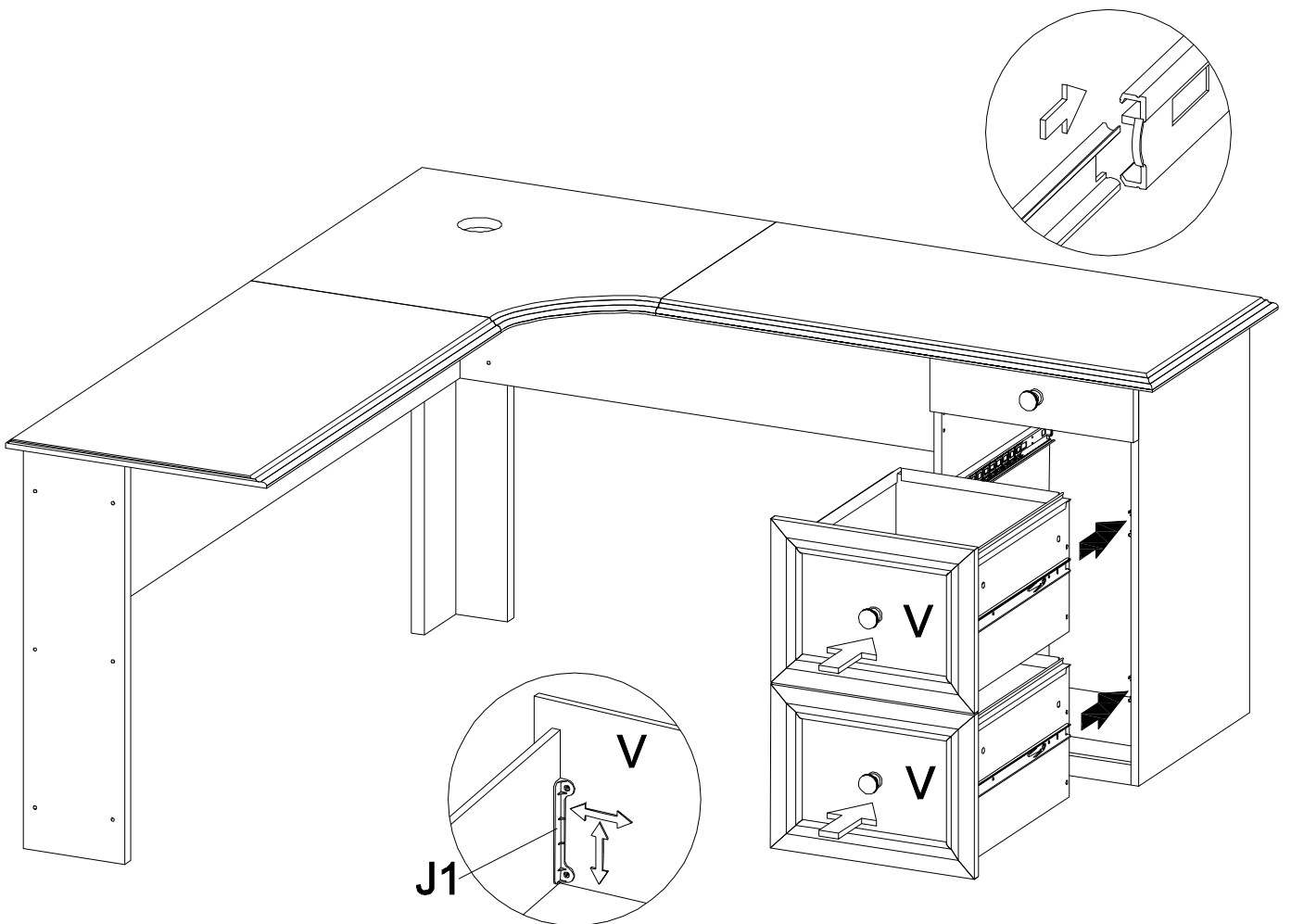
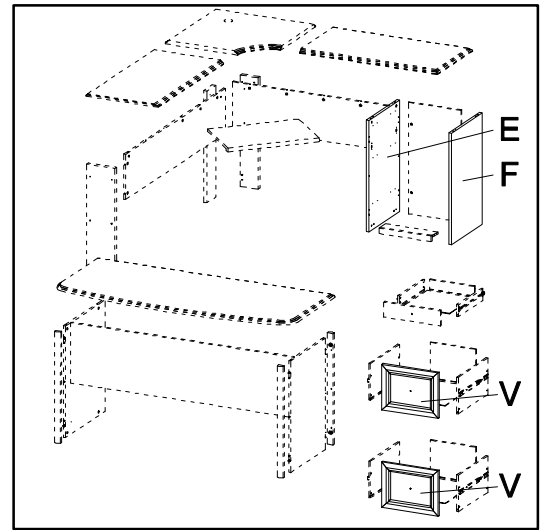

# STEP 30

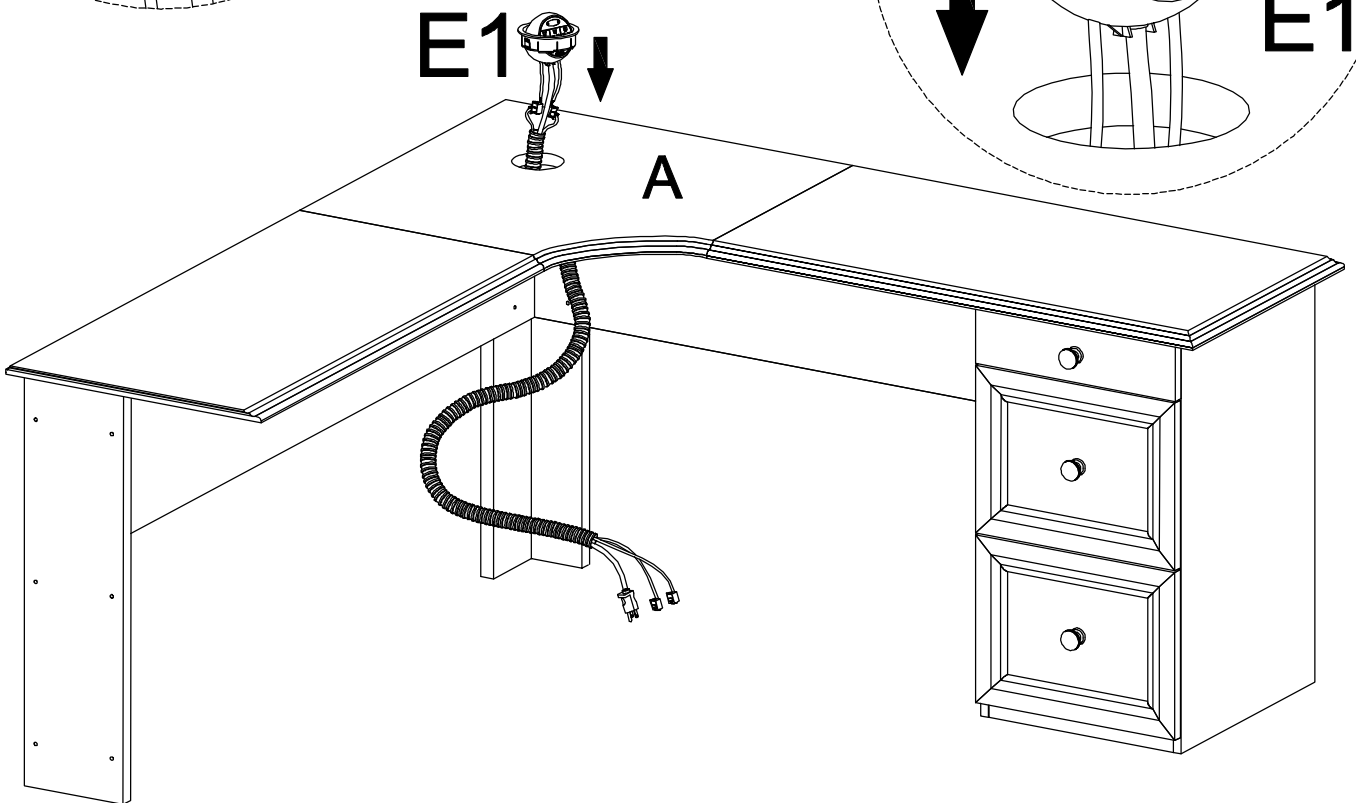
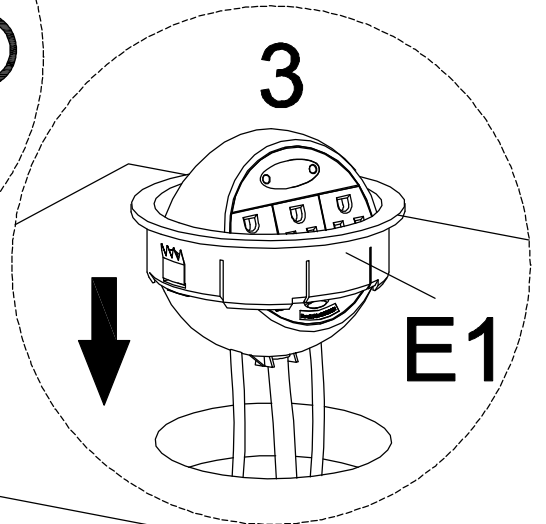
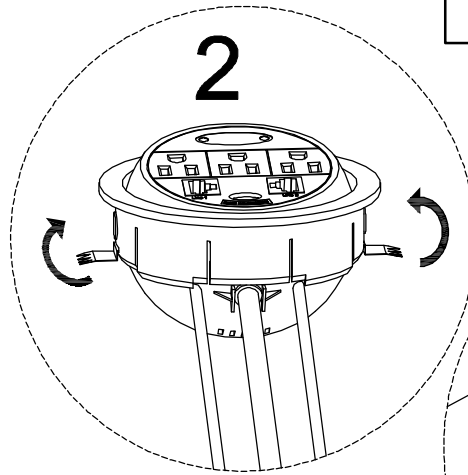
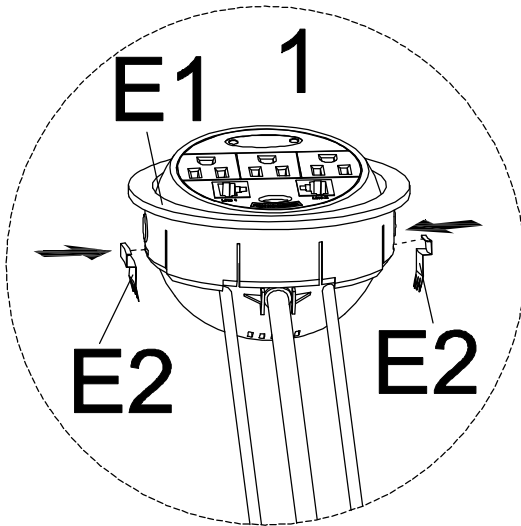
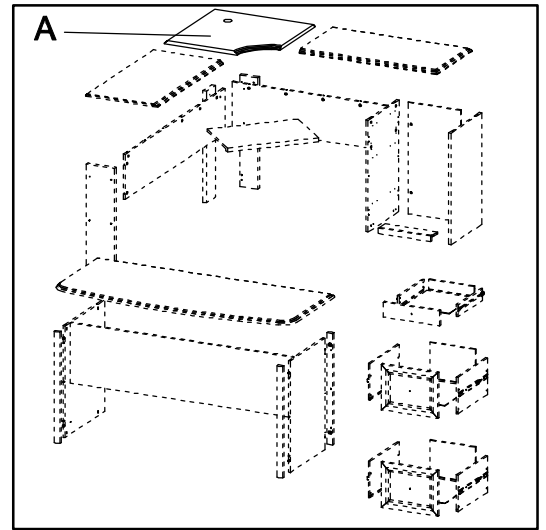
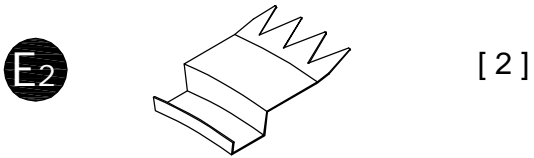
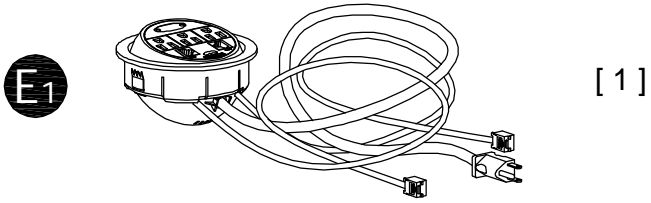

# STEP 31

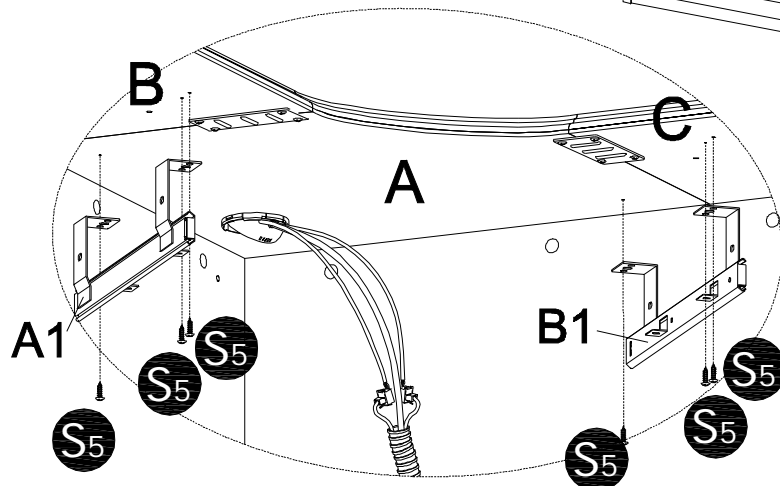
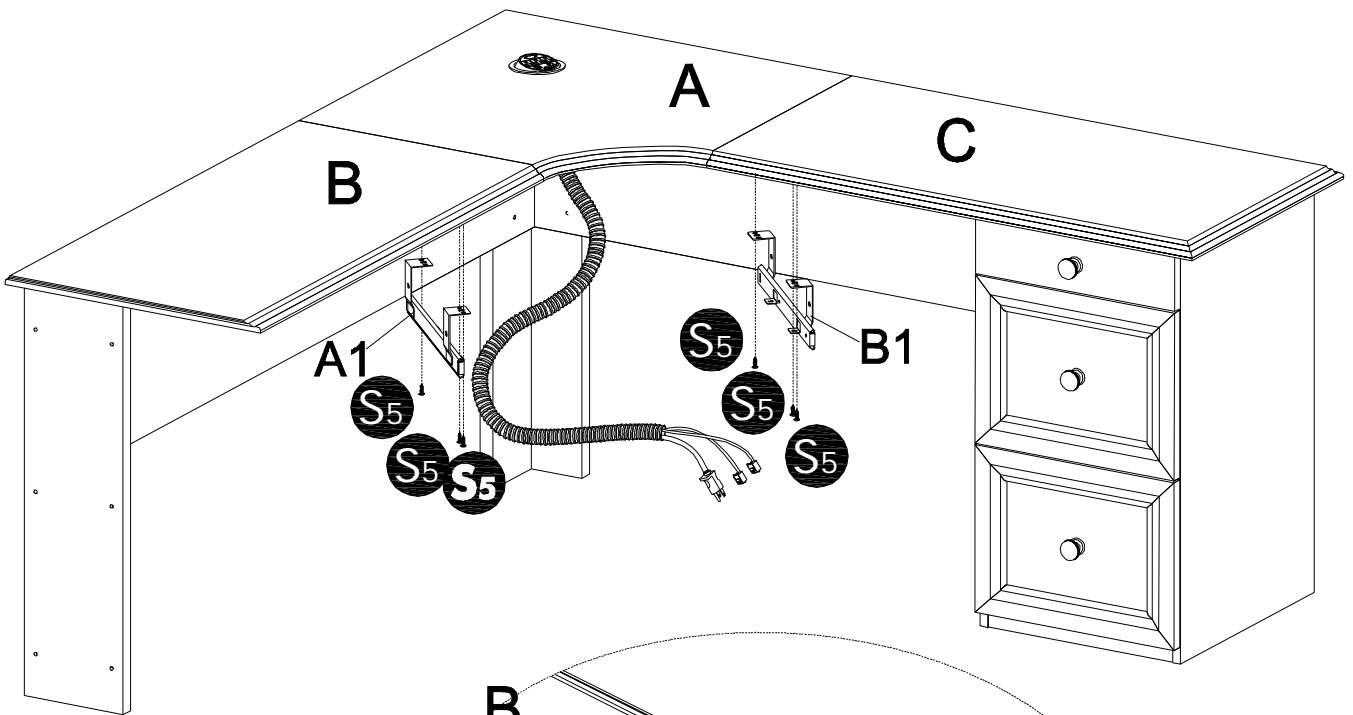
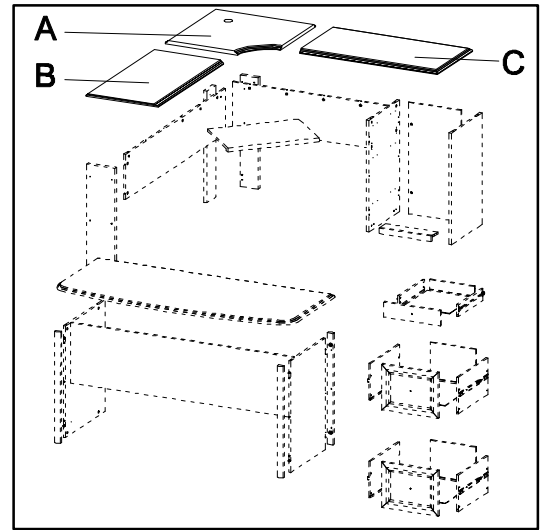
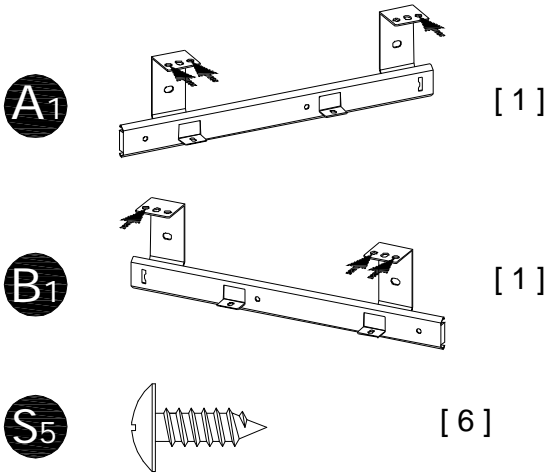



# STEP 32

S4

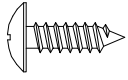

[ 4 ]

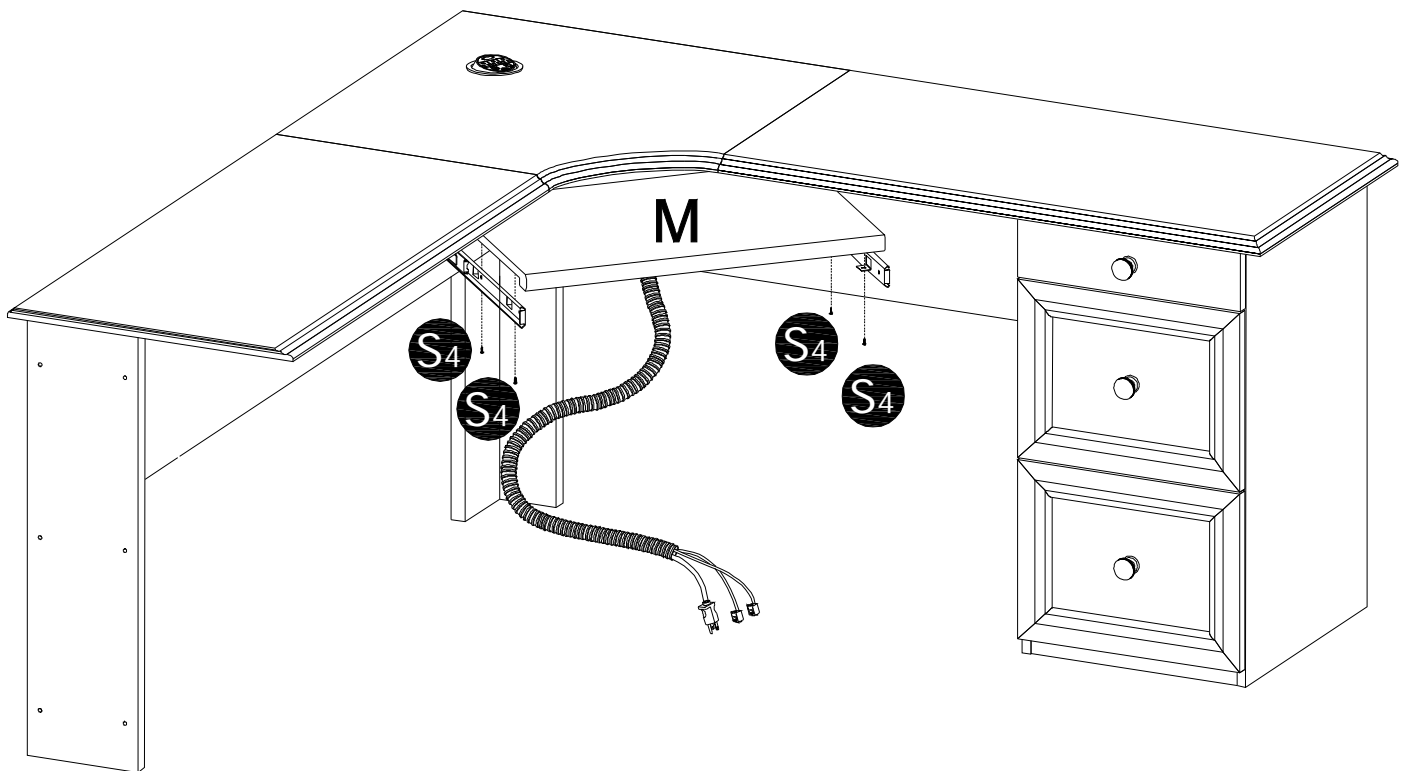
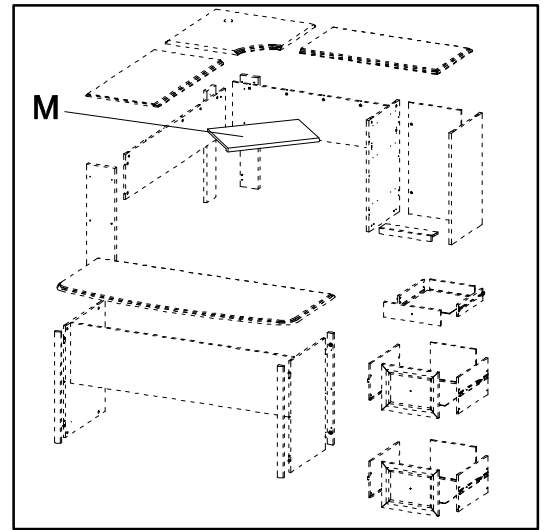

# STEP 33

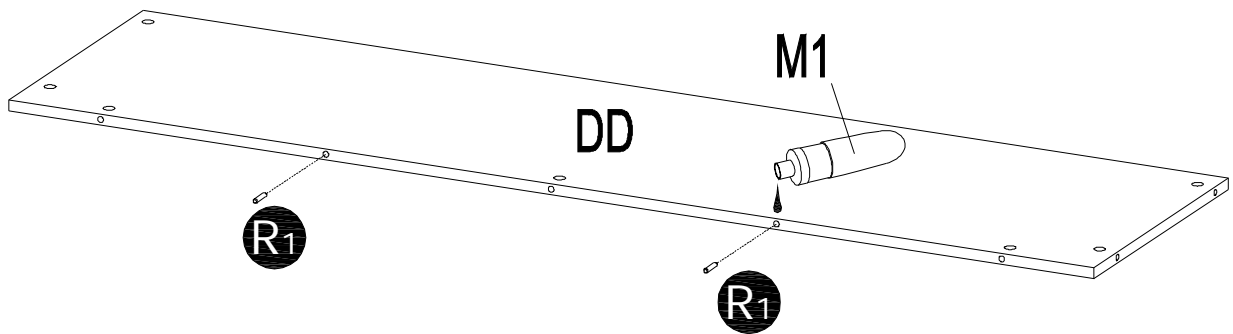
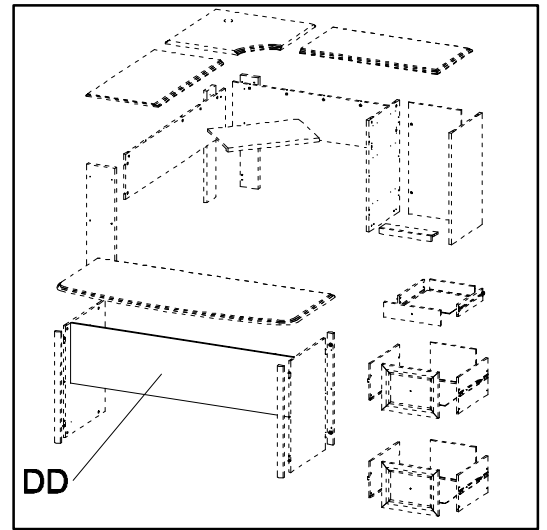
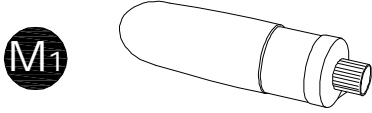

# STEP 34

G1



[ 4 ]

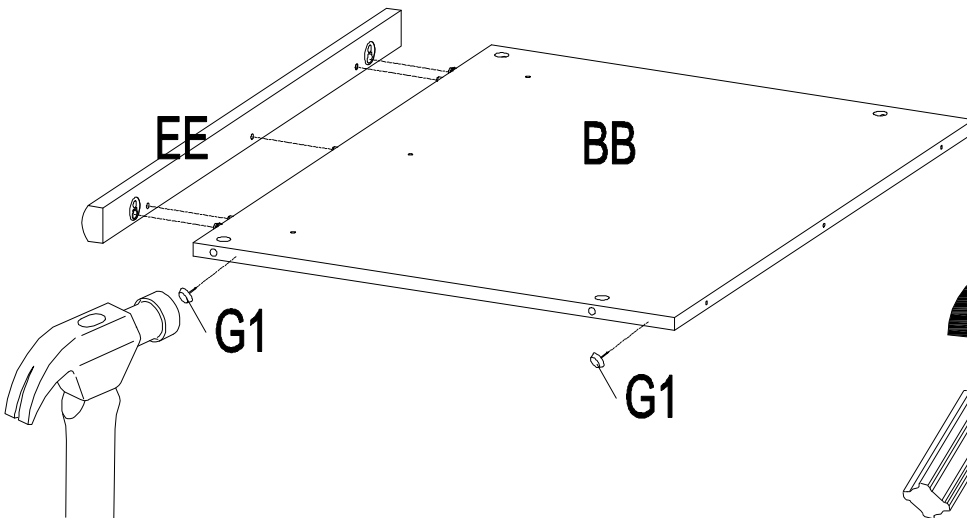
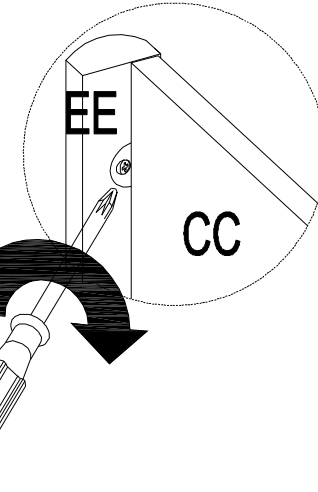
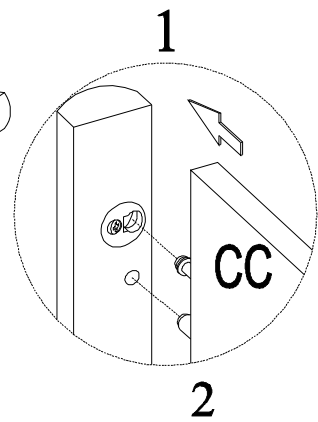
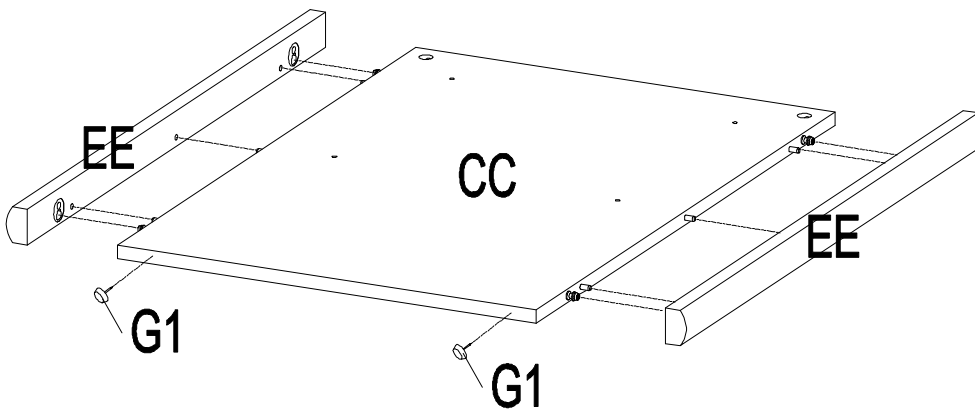
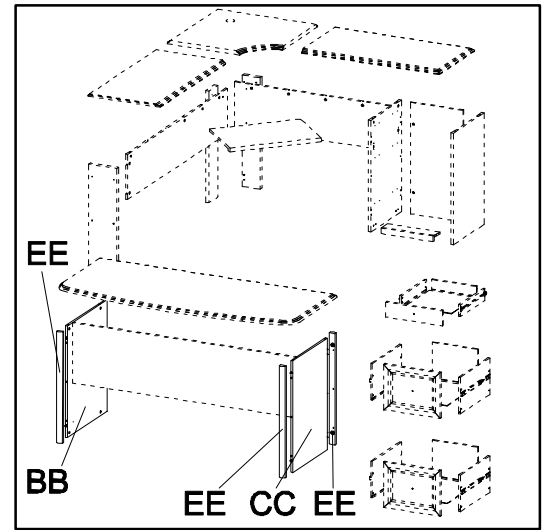

# STEP 35

Q<sub>1</sub>

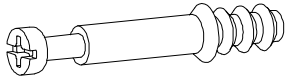

[4]

L<sub>1</sub>



[2]

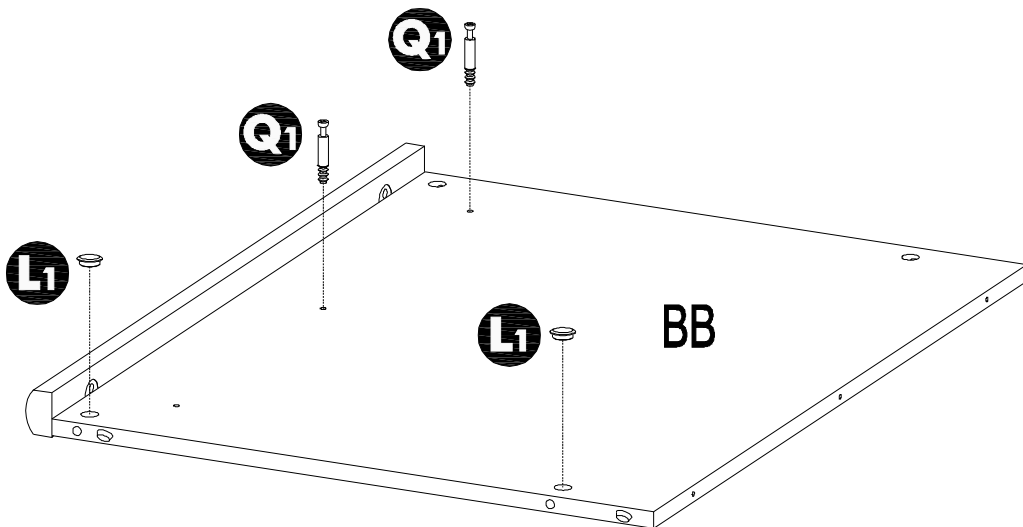
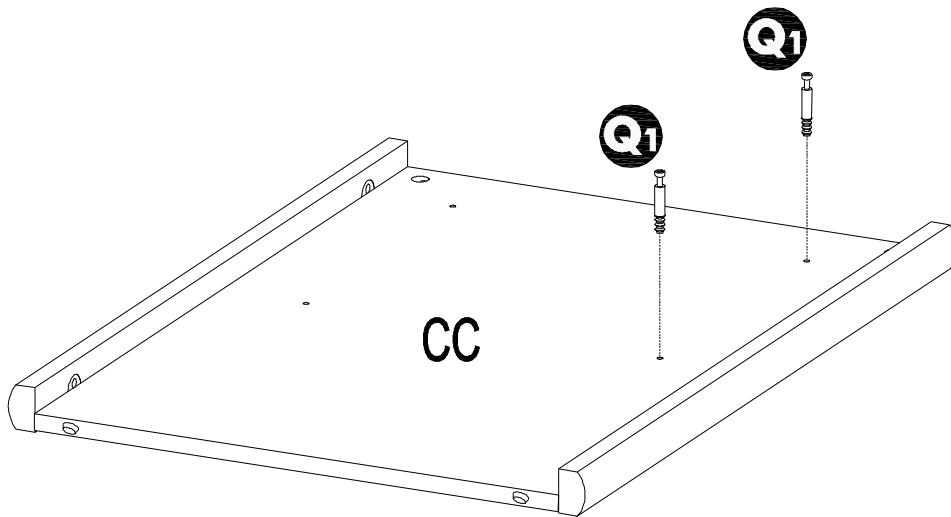
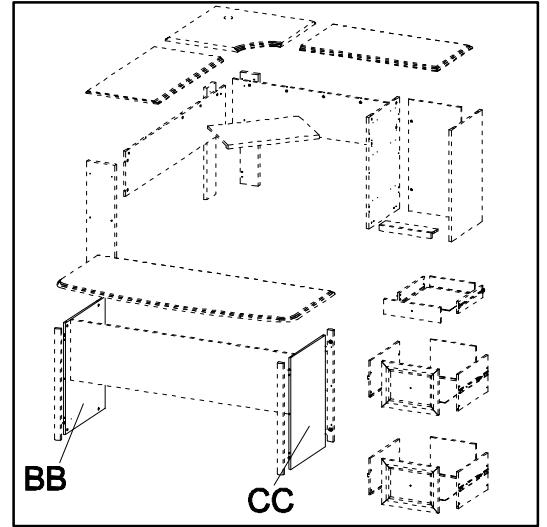

# STEP 36

P<sub>1</sub>

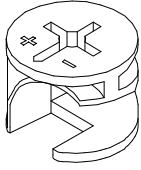

[2]

F<sub>1</sub>

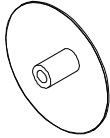

[2]

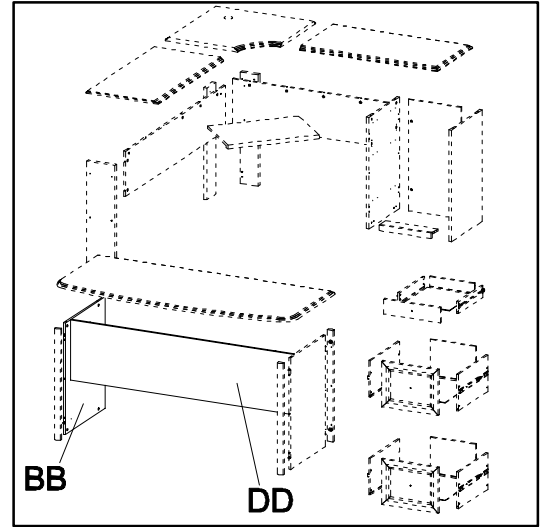

BB

DD

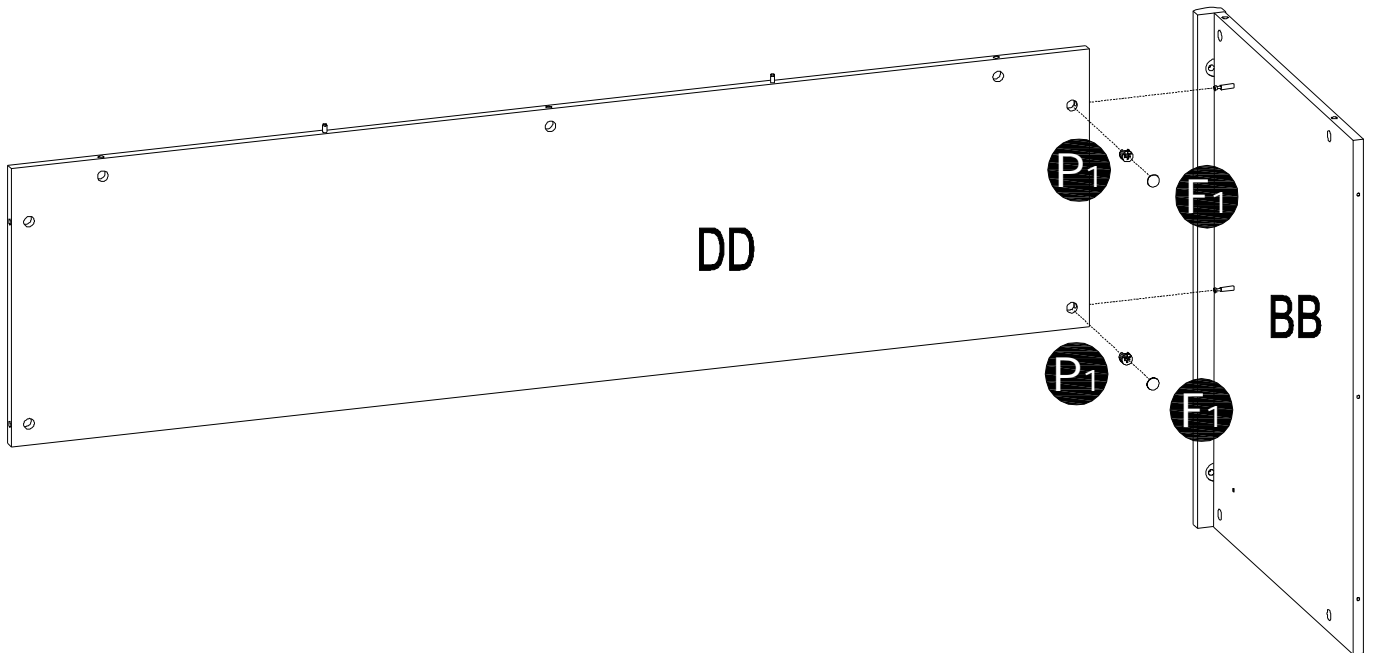

DD

P<sub>1</sub>

F<sub>1</sub>

BB

P<sub>1</sub>

F<sub>1</sub>

# STEP 37

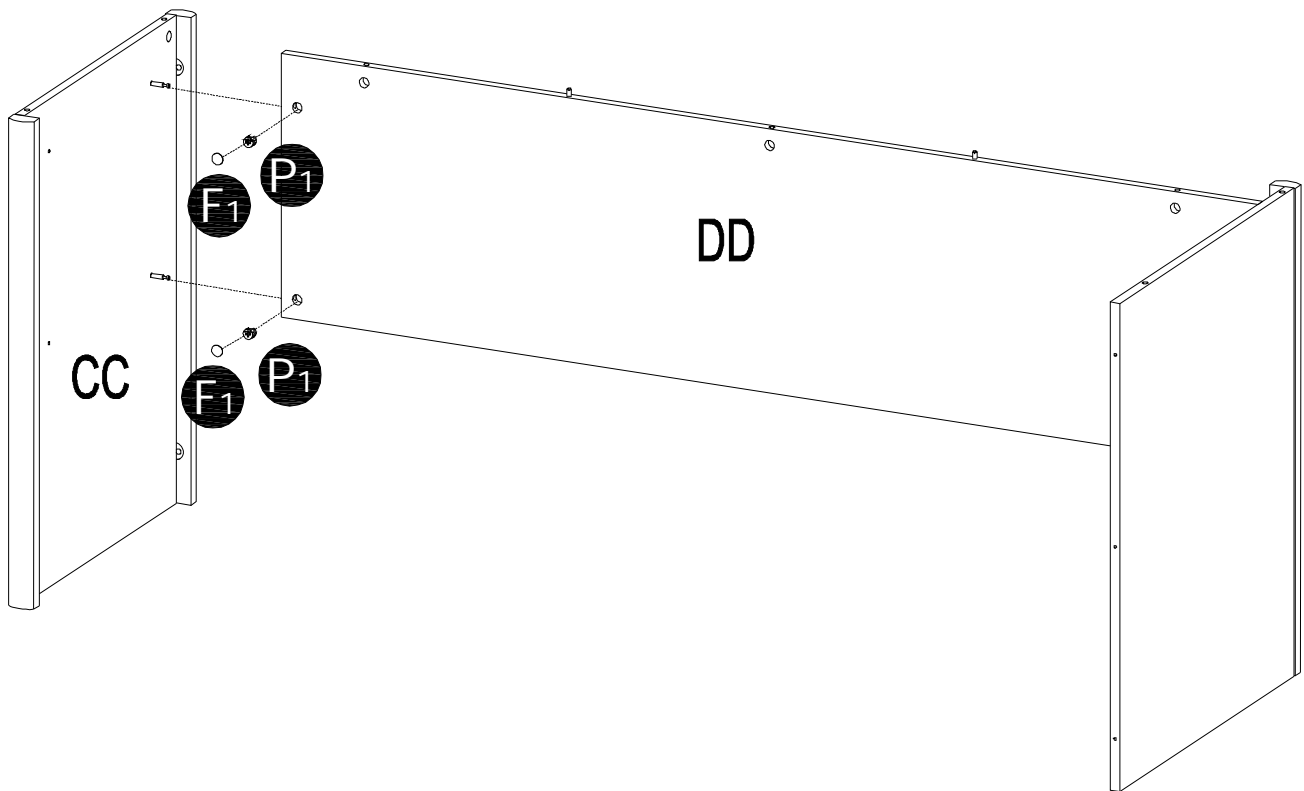
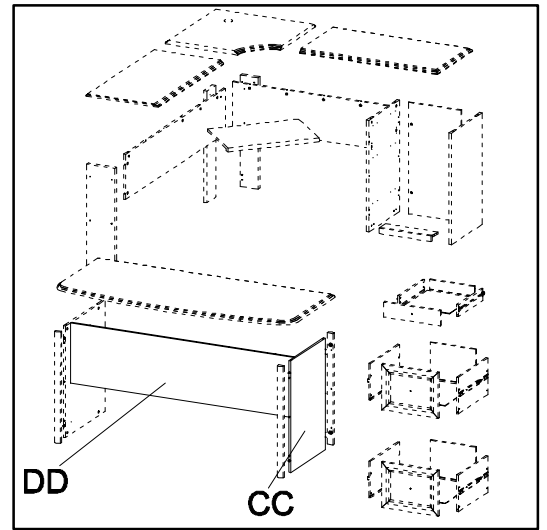
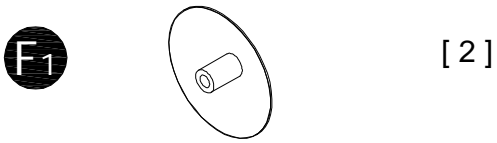
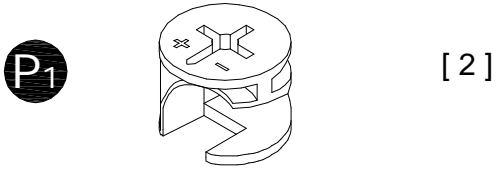

# STEP 38

Q1

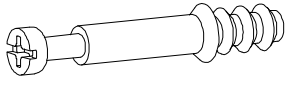

[7]

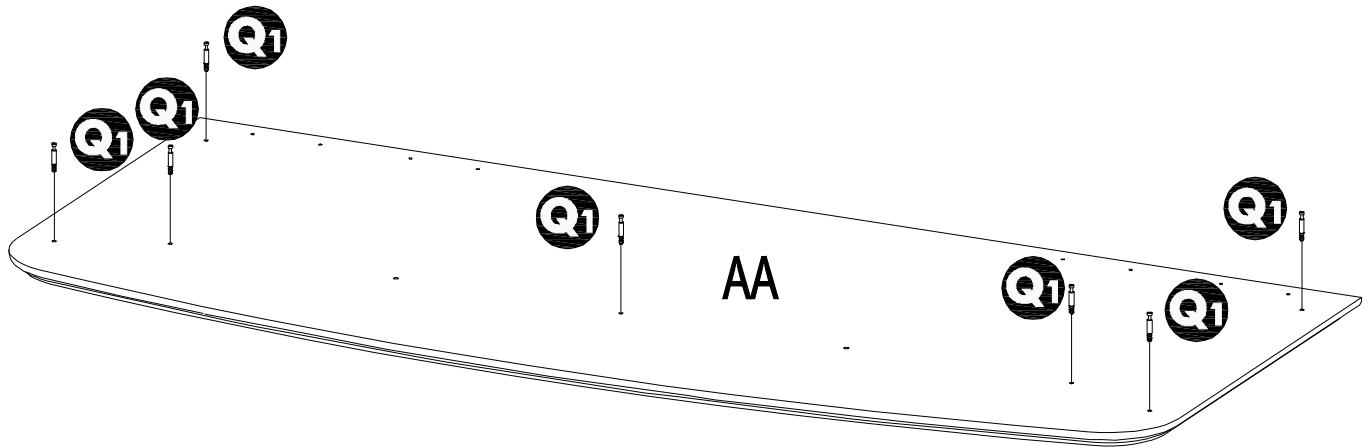
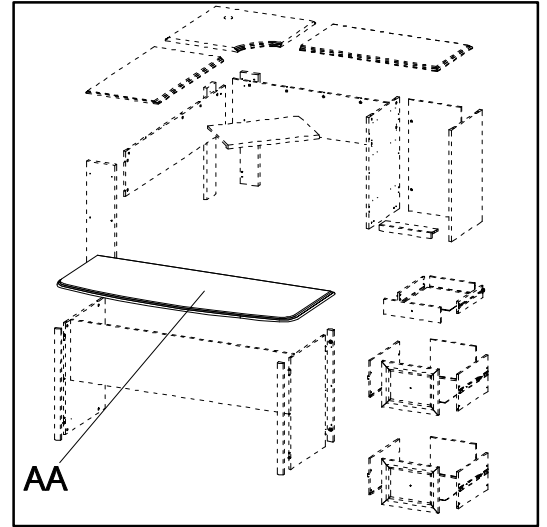





# STEP 40

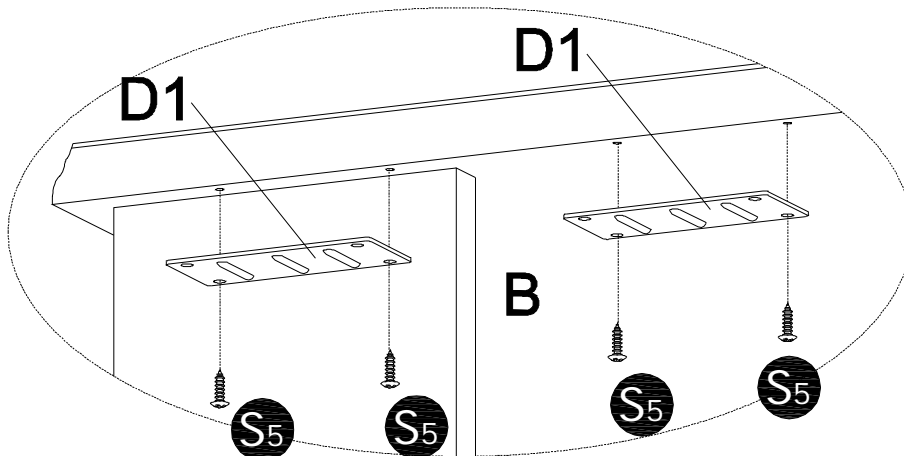
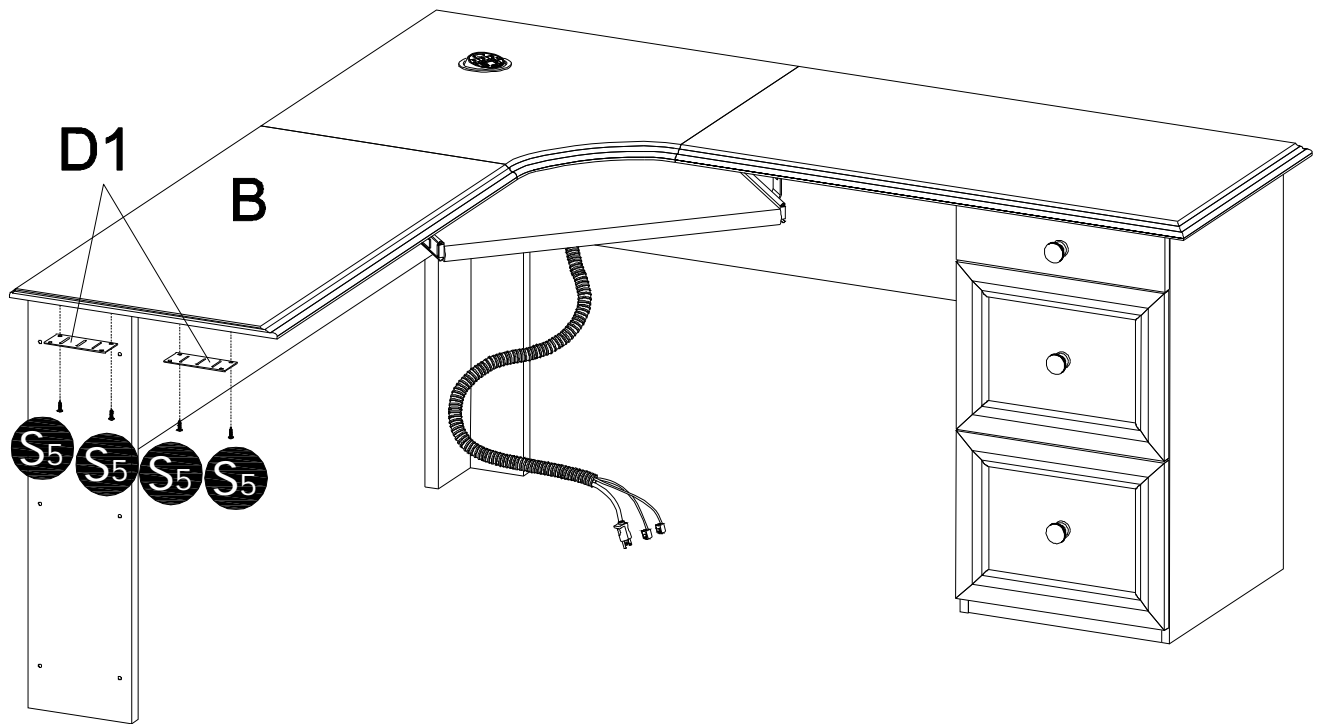
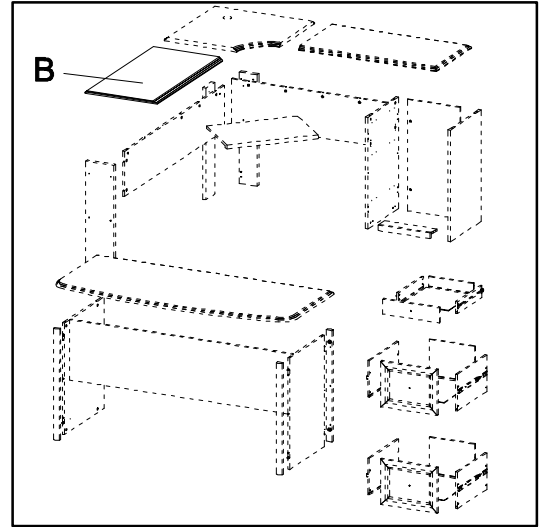
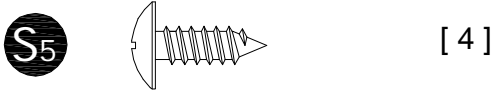
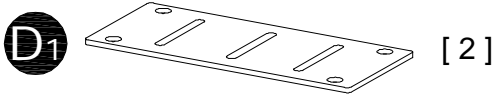

# STEP 41

S1

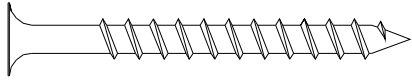

[ 3 ]

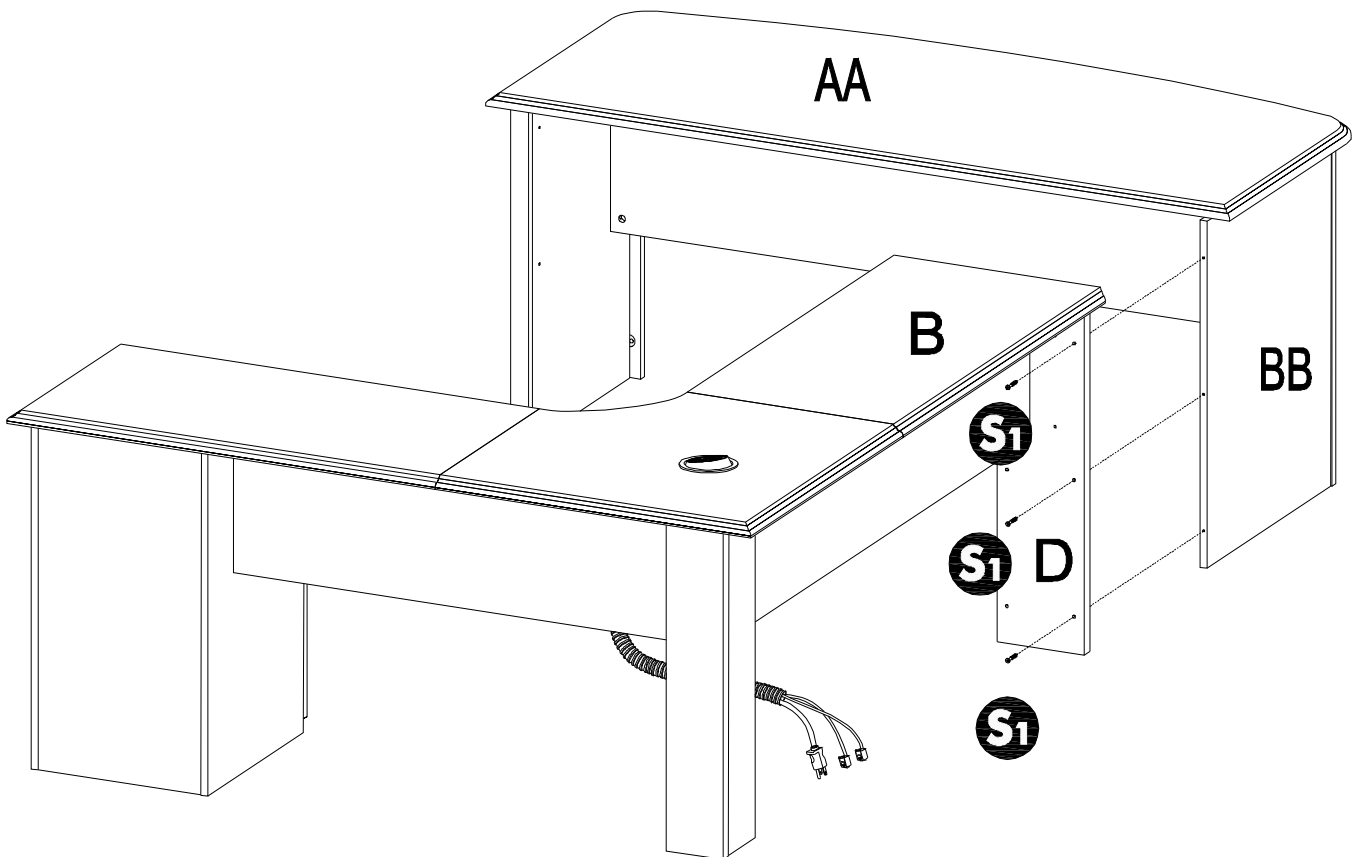
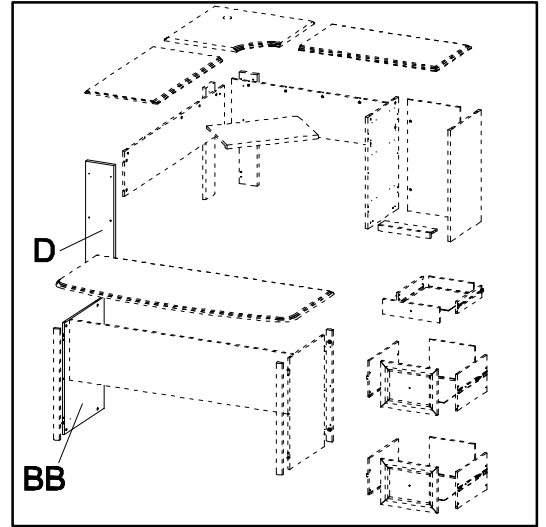

# STEP 42

S5

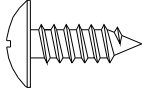

[ 4 ]

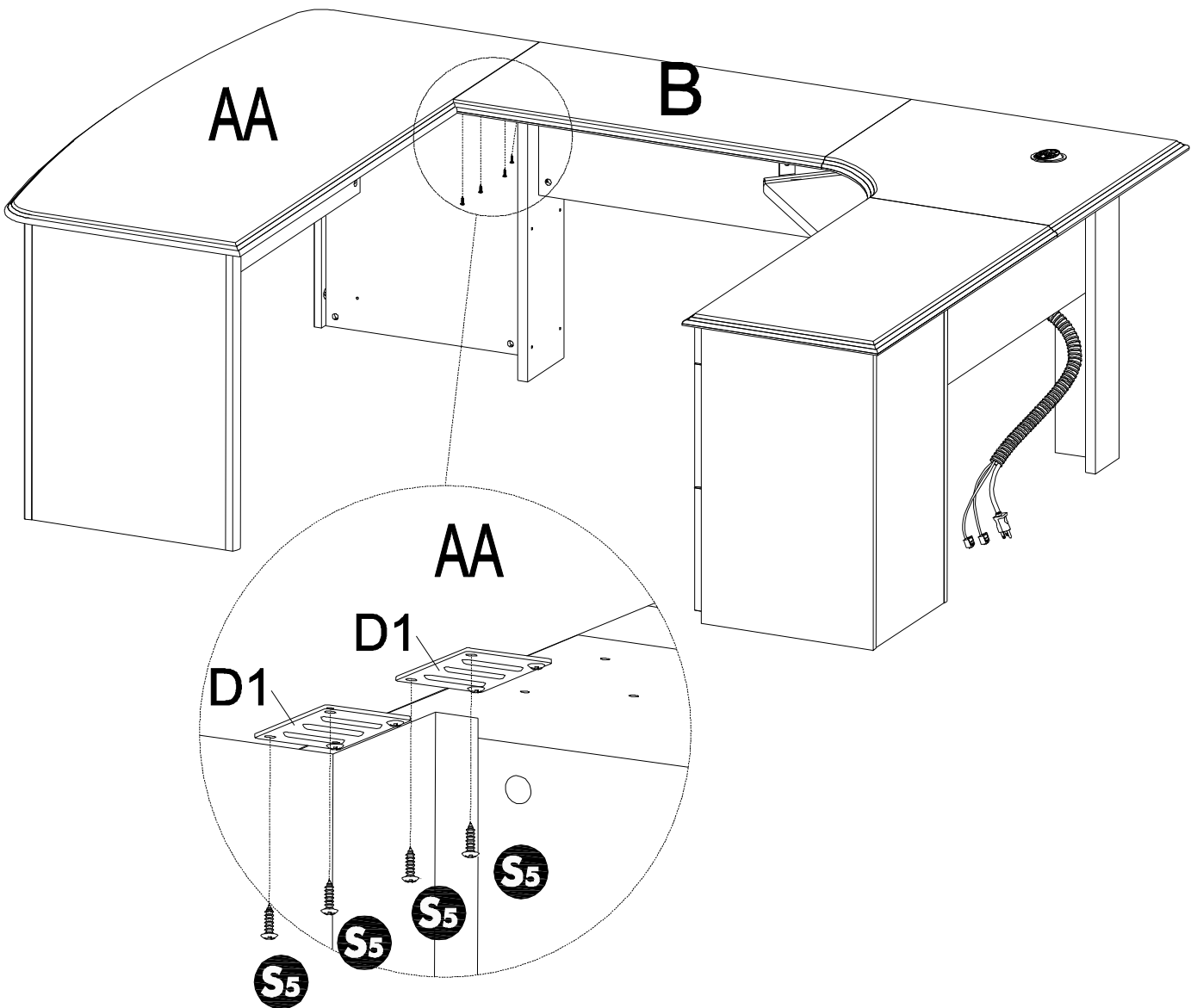
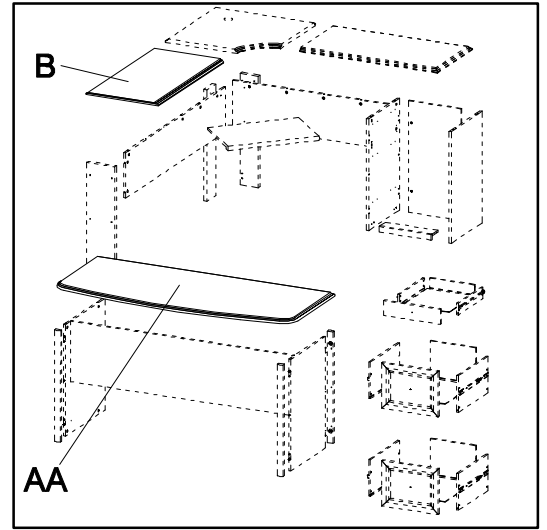

# STEP 43

S<sub>3</sub>

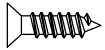

[ 6 ]

S<sub>4</sub>

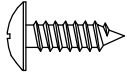

[ 12 ]

U<sub>1</sub>

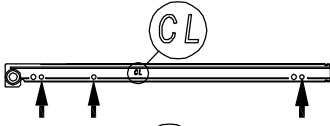

[ 1 ]

V<sub>1</sub>

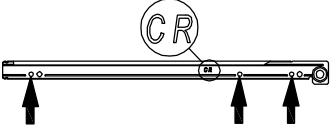

[ 1 ]

T<sub>1</sub>

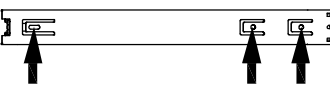

[ 4 ]

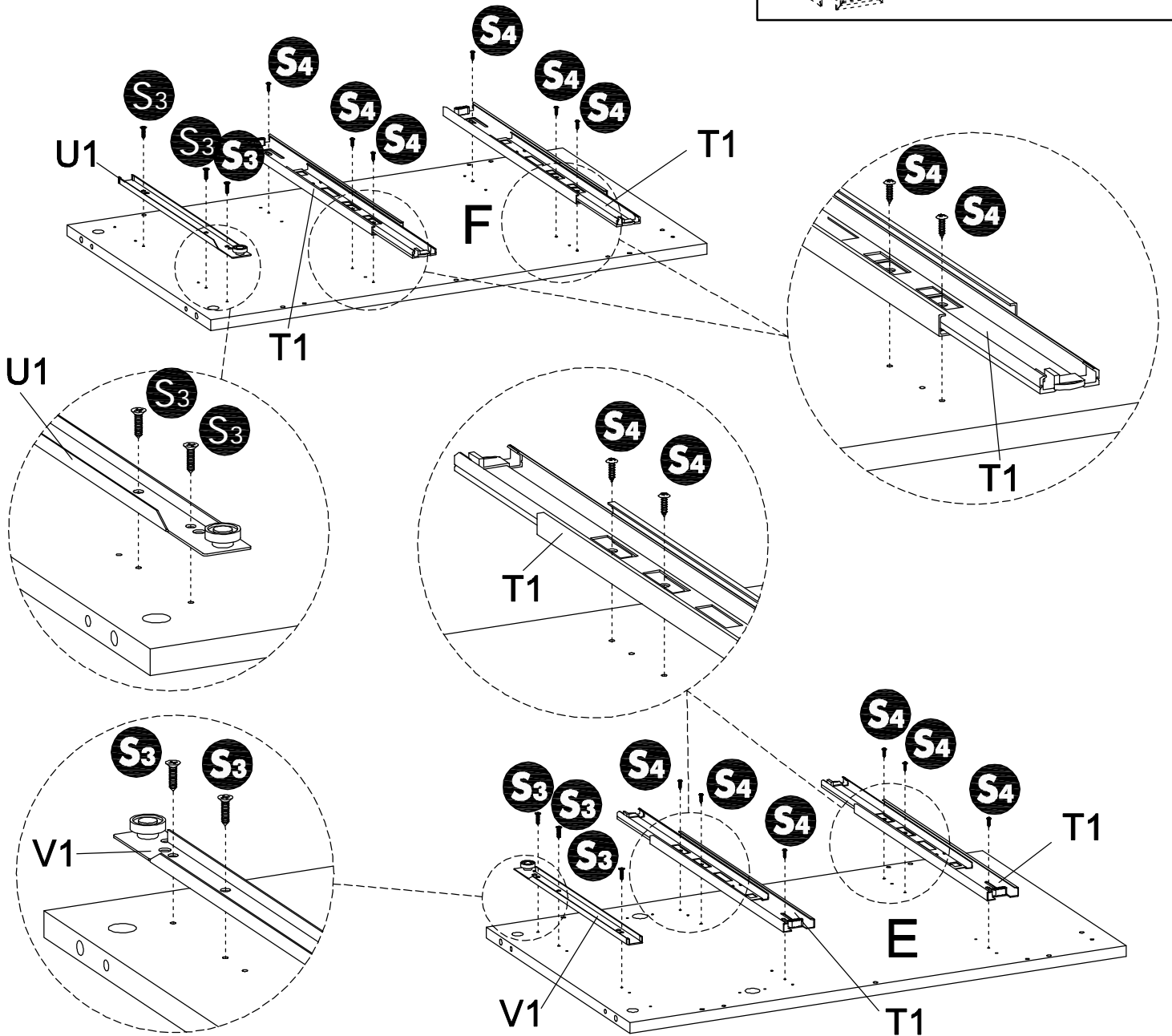
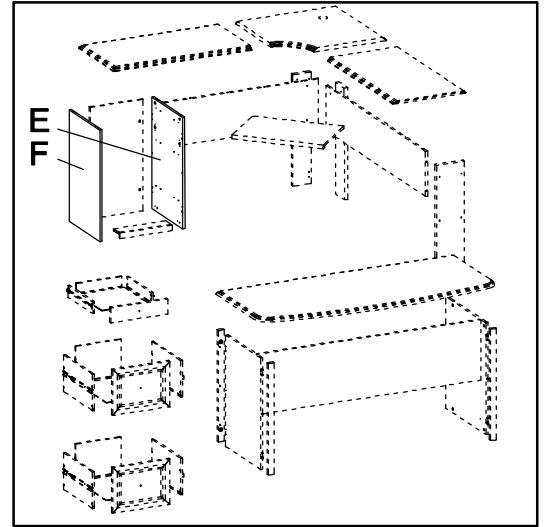

# STEP 44

O<sub>1</sub>

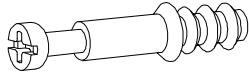

[ 6 ]

R<sub>1</sub>



[ 4 ]

M<sub>1</sub>

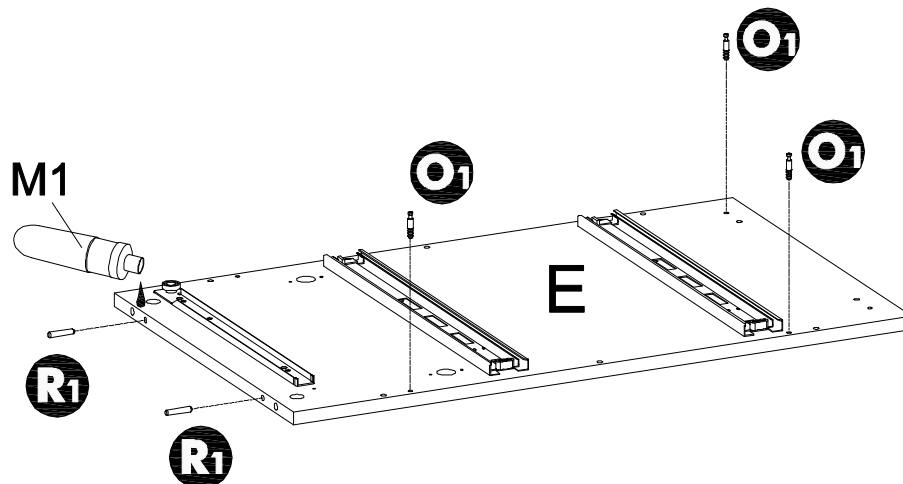
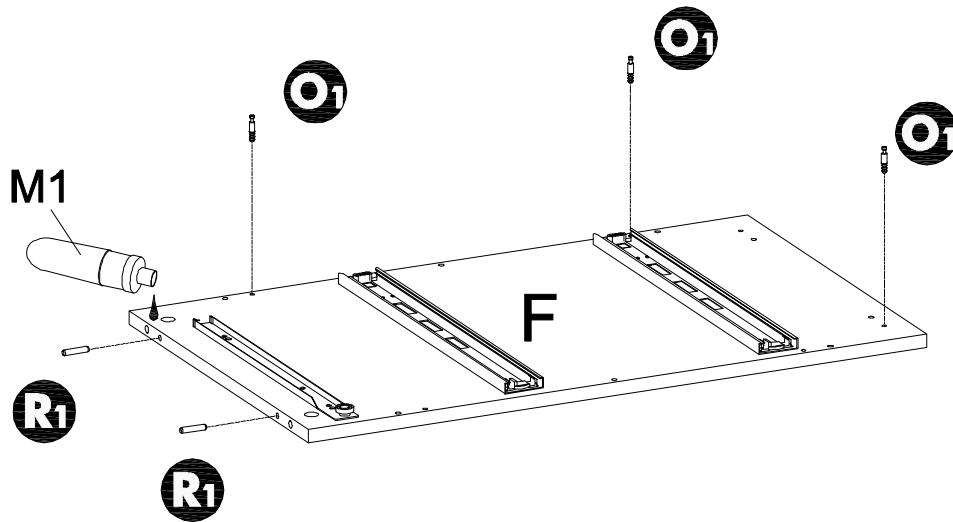
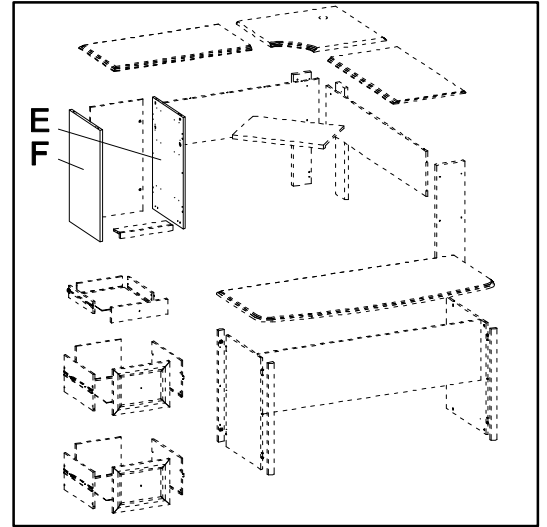
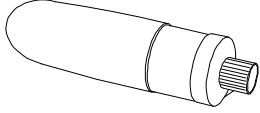

# STEP 45

S4

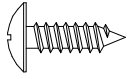

[2]

H1

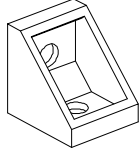

[2]

R1



[10]

M1

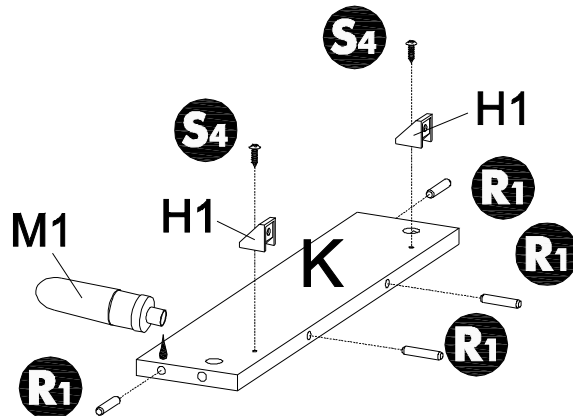
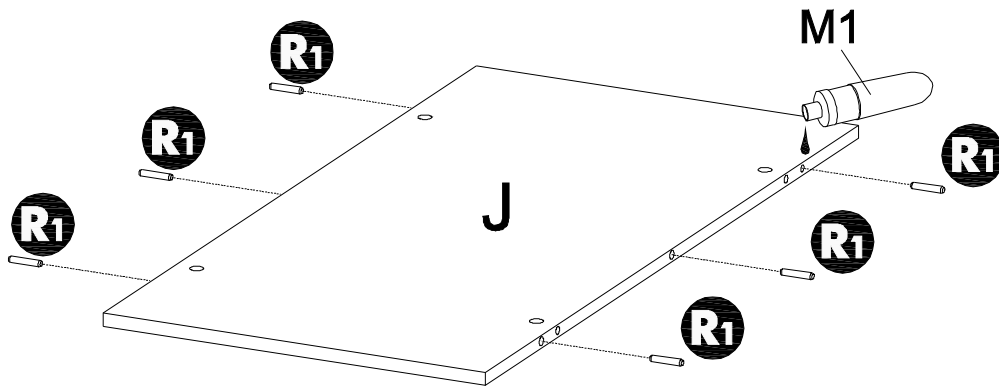
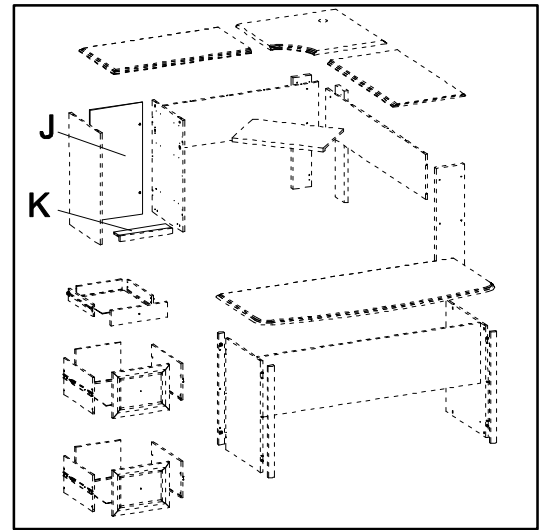
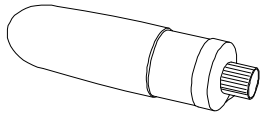

# STEP 46

S4

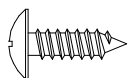

[ 2 ]

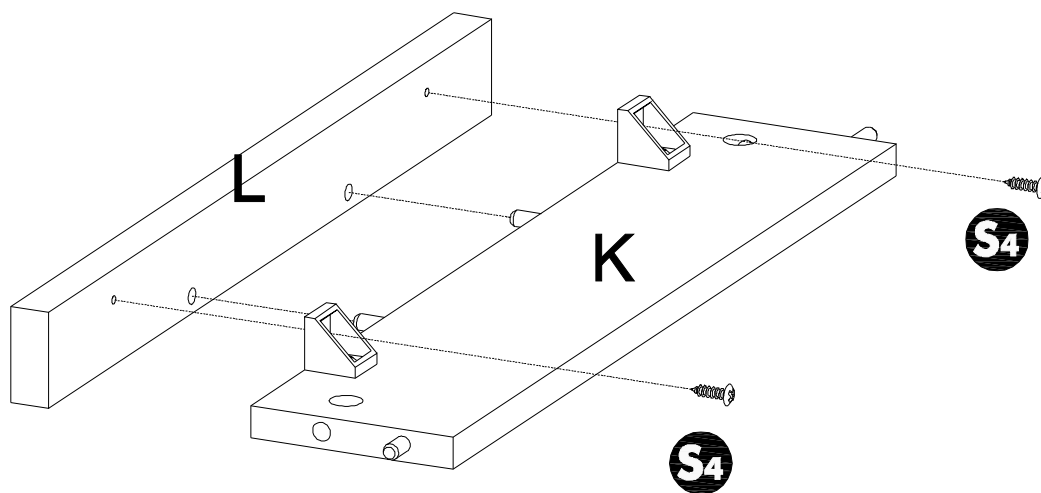
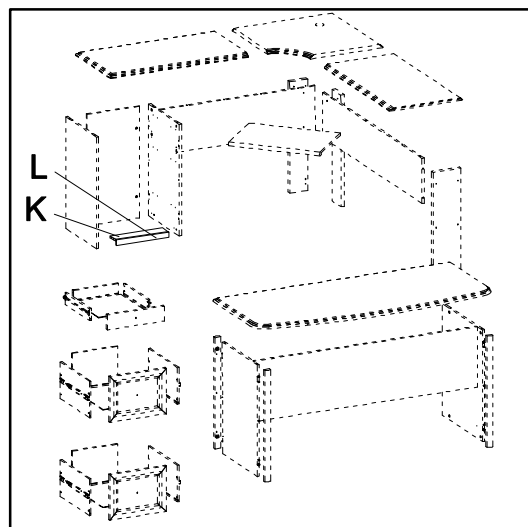

# STEP 47

N<sub>1</sub>

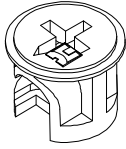

[ 3 ]

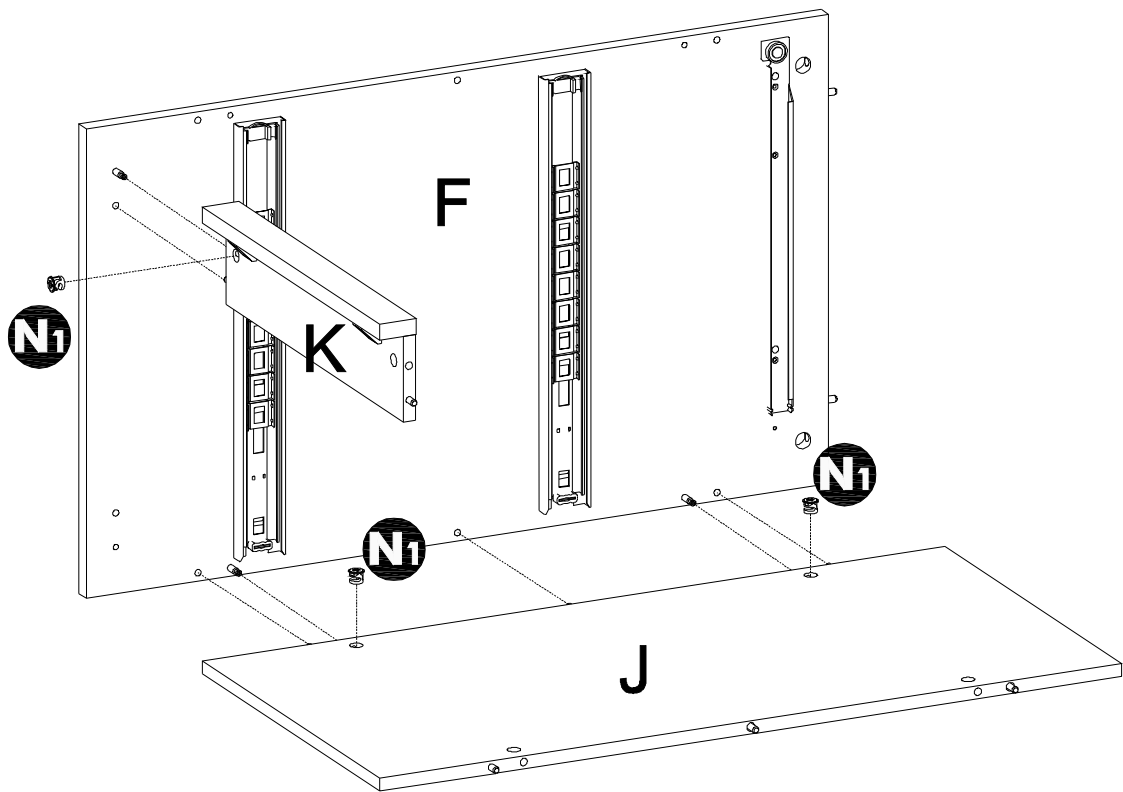
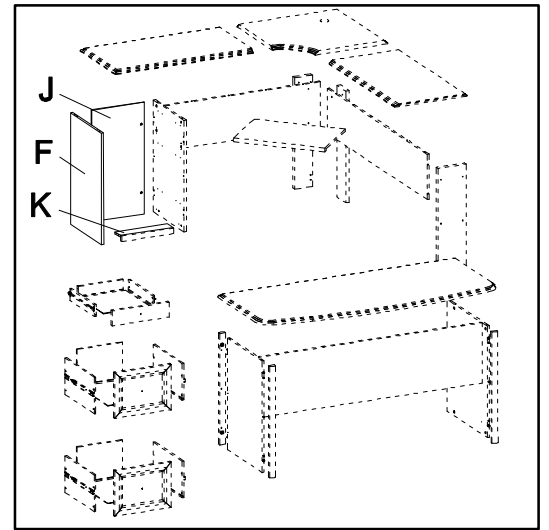



# STEP 48

N<sub>1</sub>

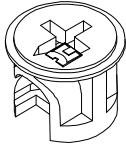

[ 3 ]

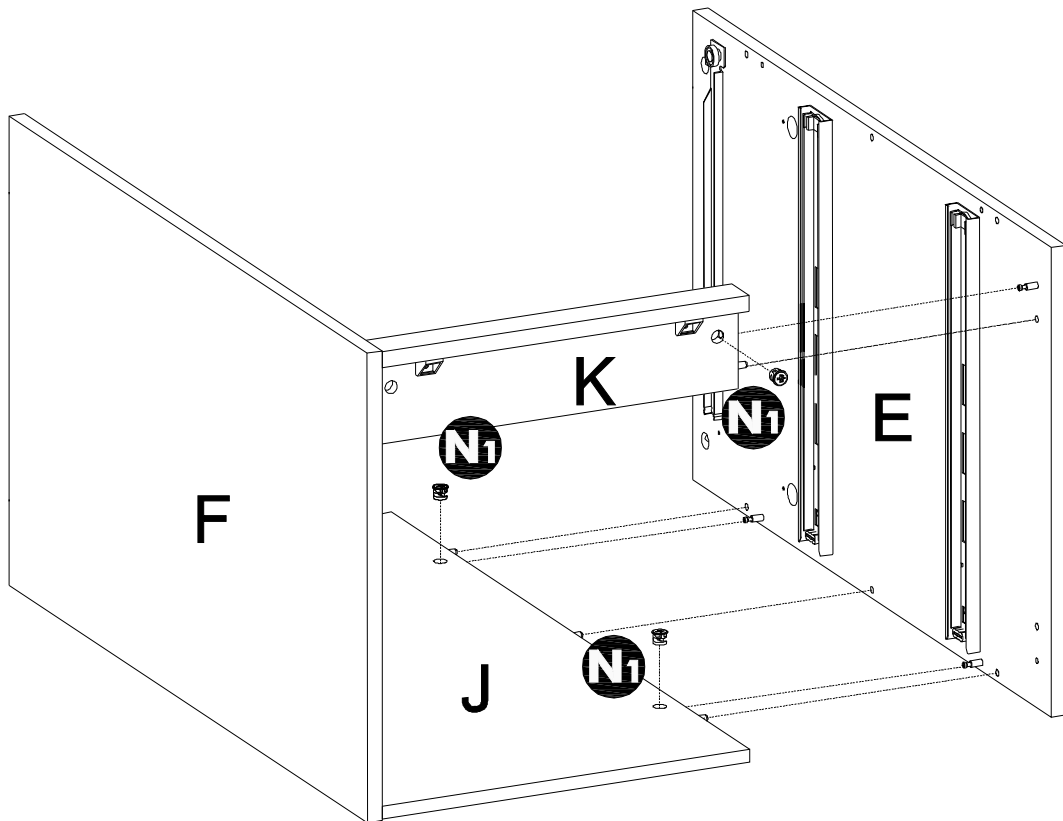
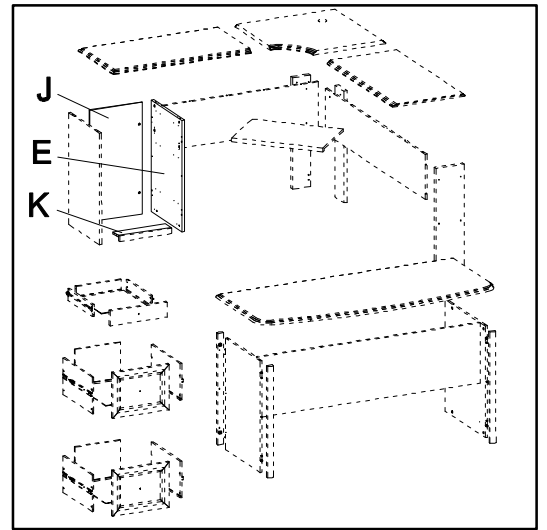

# STEP 49

G1



[ 4 ]

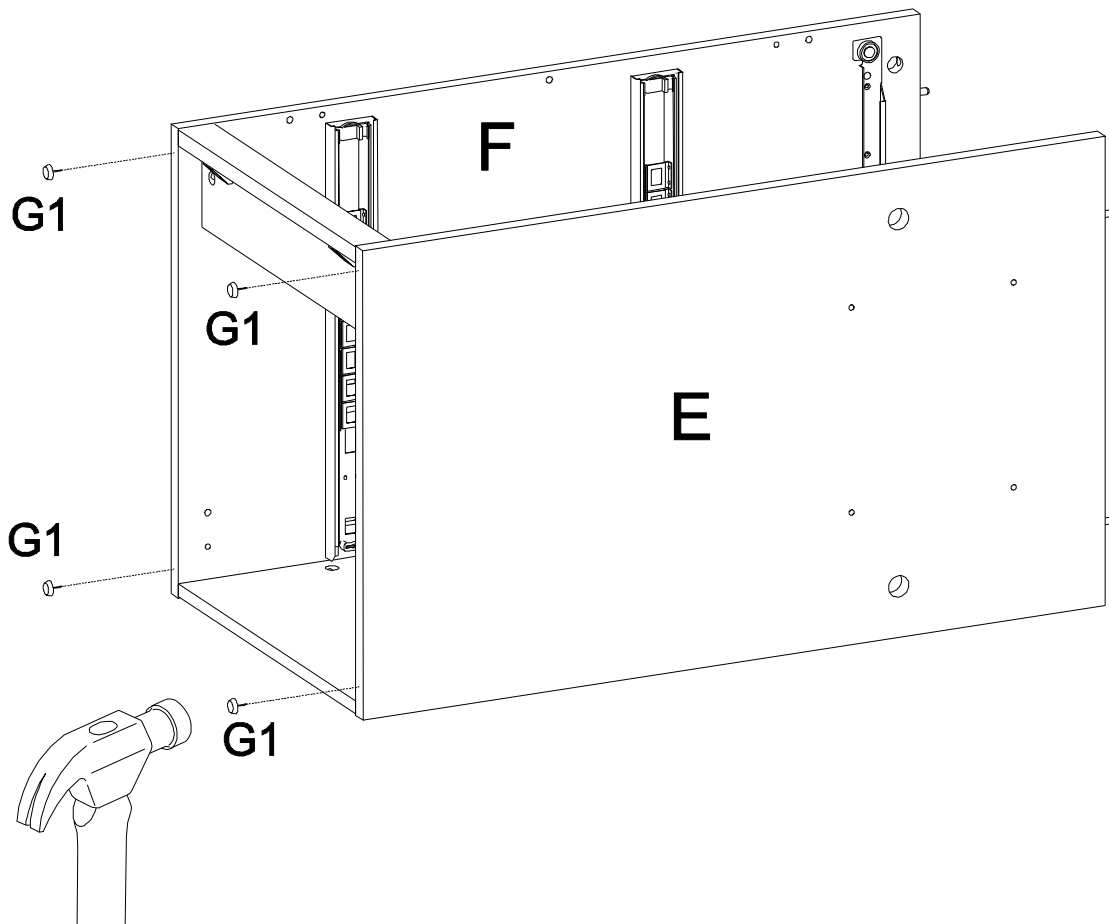
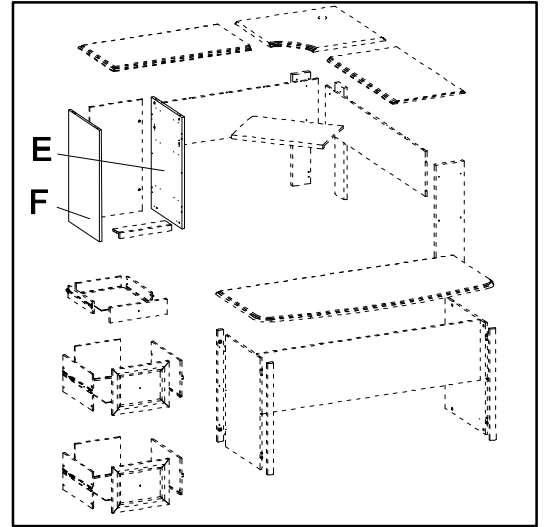

# STEP 50

Q1

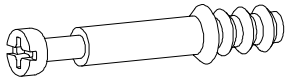

[2]

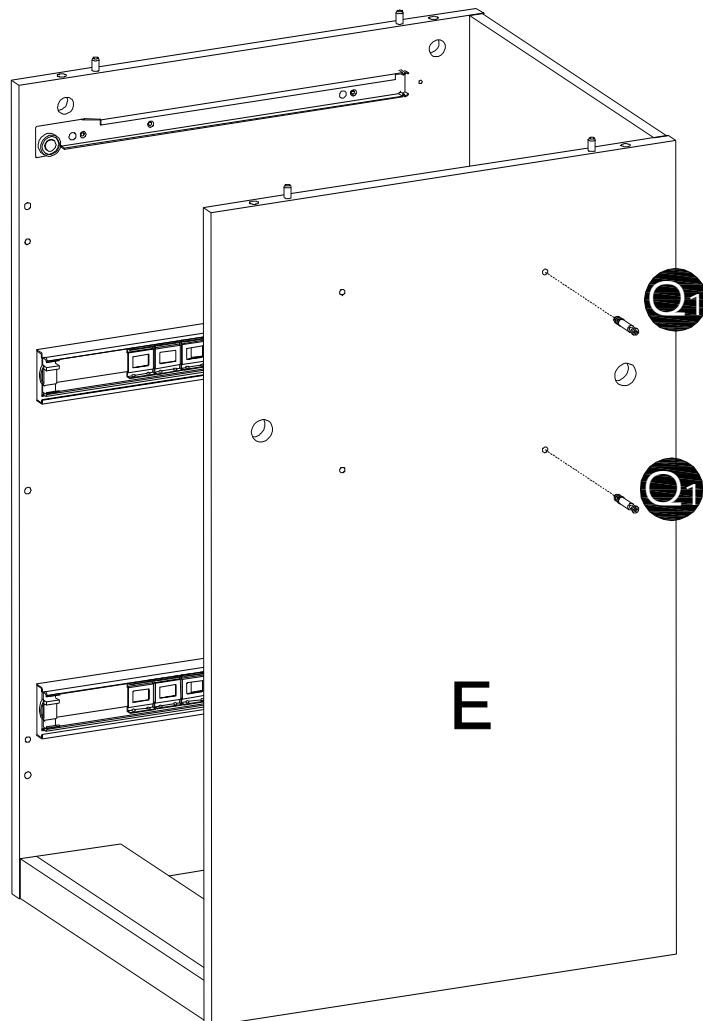
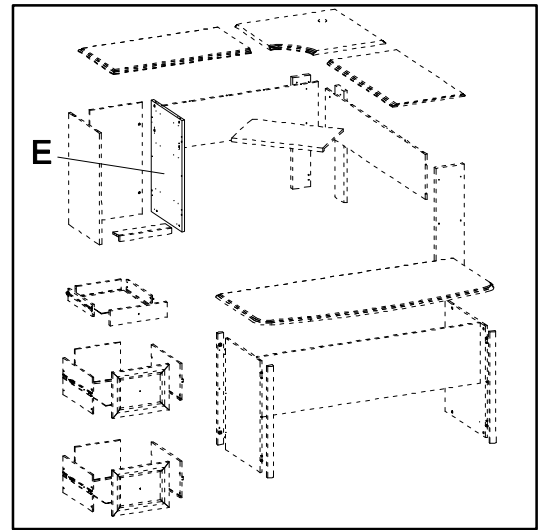



# STEP 52

S2

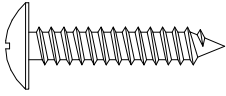

[2]

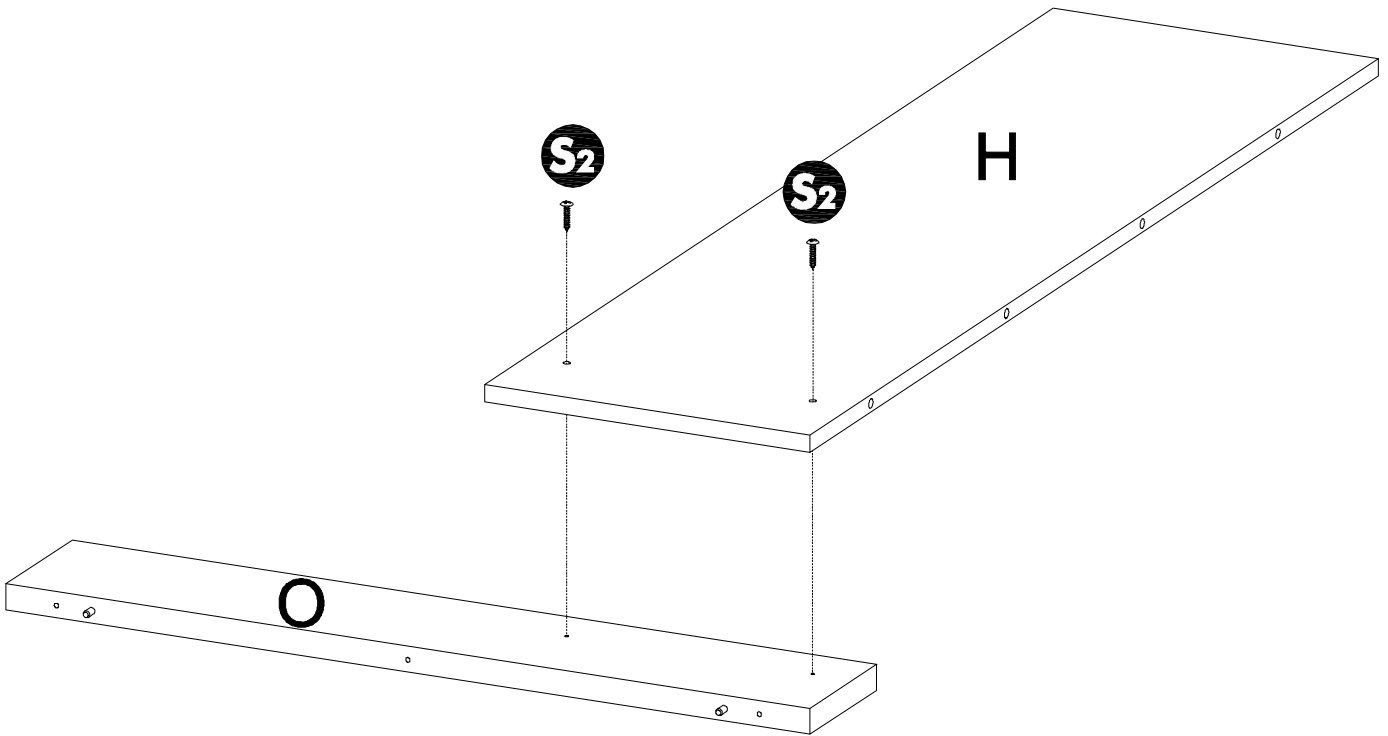
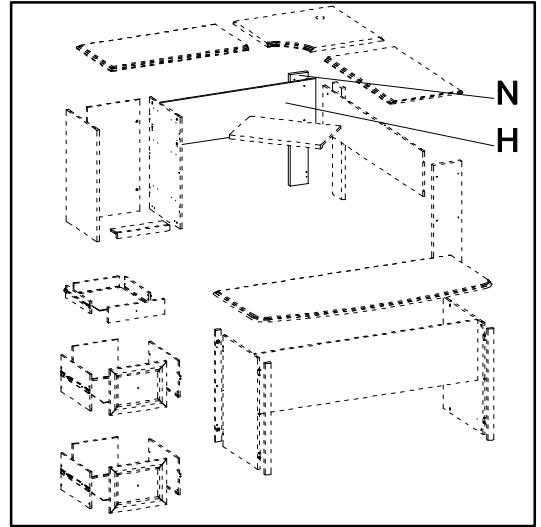

# STEP 53

P<sub>1</sub>

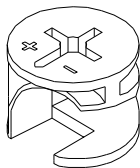

[2]

F<sub>1</sub>

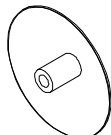

[2]

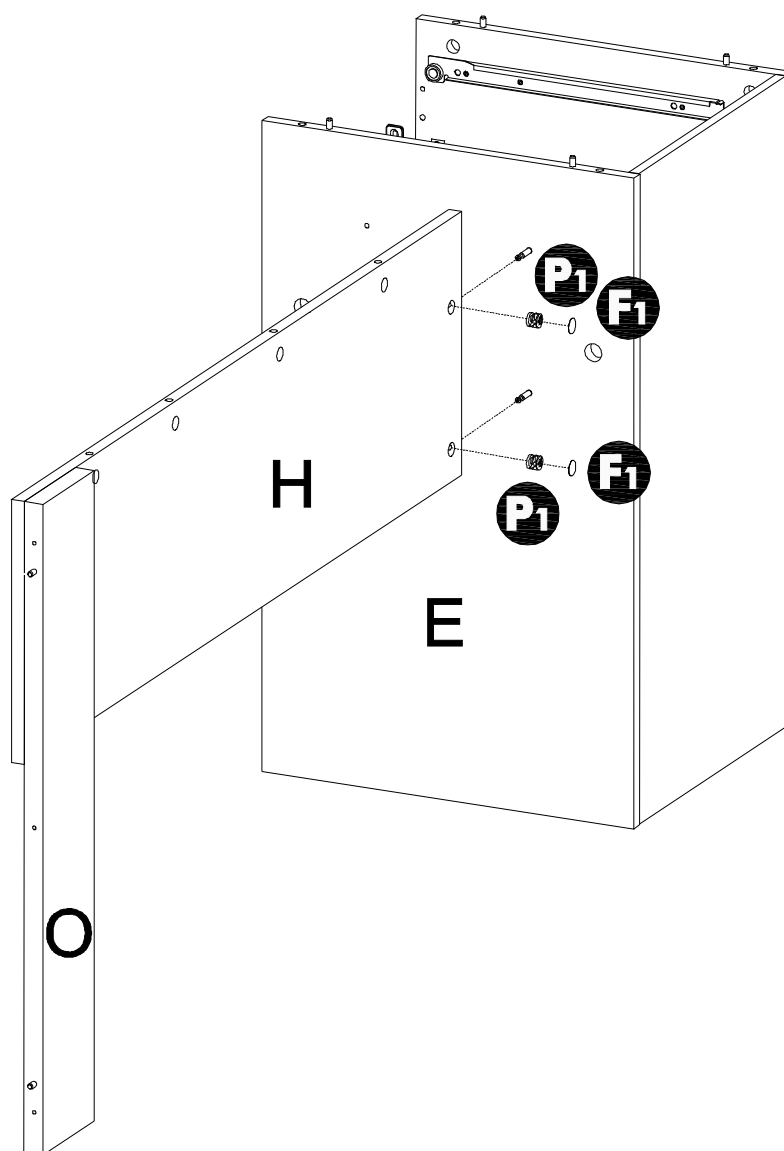
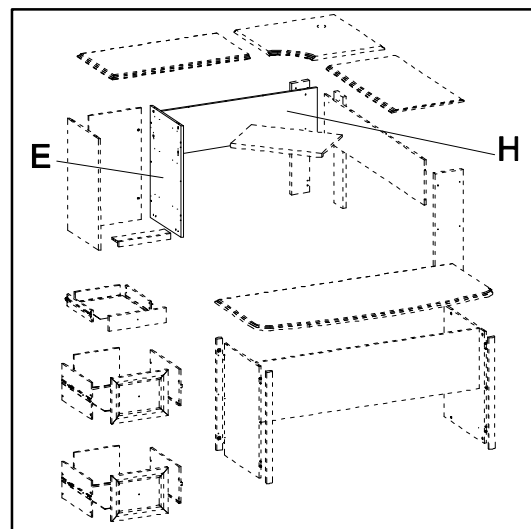

# STEP 54

S<sub>2</sub>

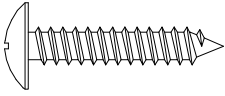

[ 2 ]

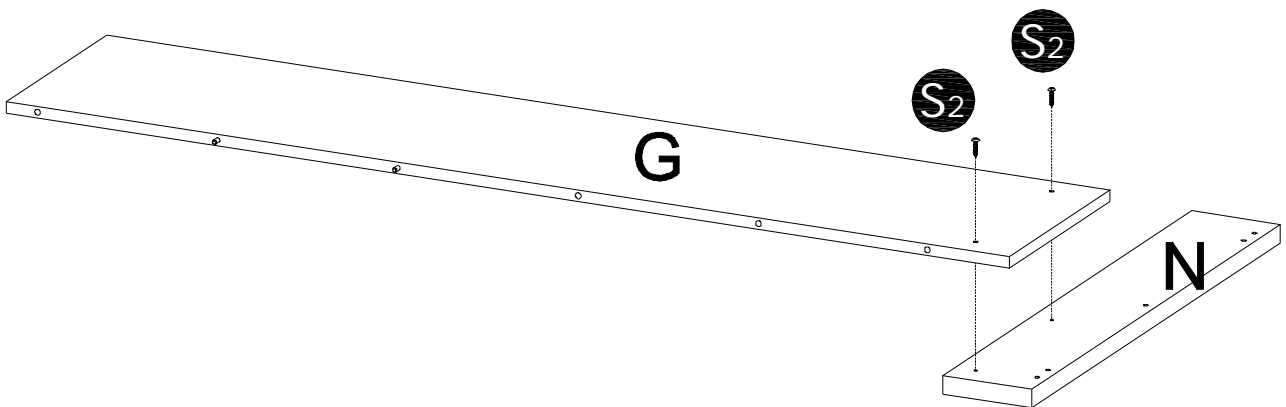
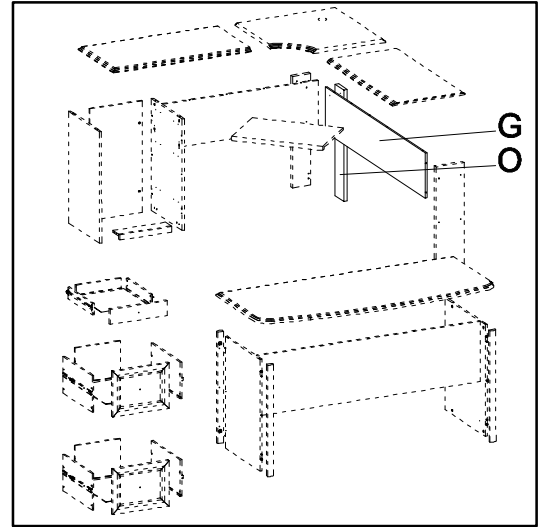

# STEP 55

P<sub>1</sub>

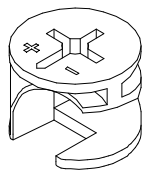

[2]

F<sub>1</sub>

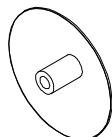

[2]

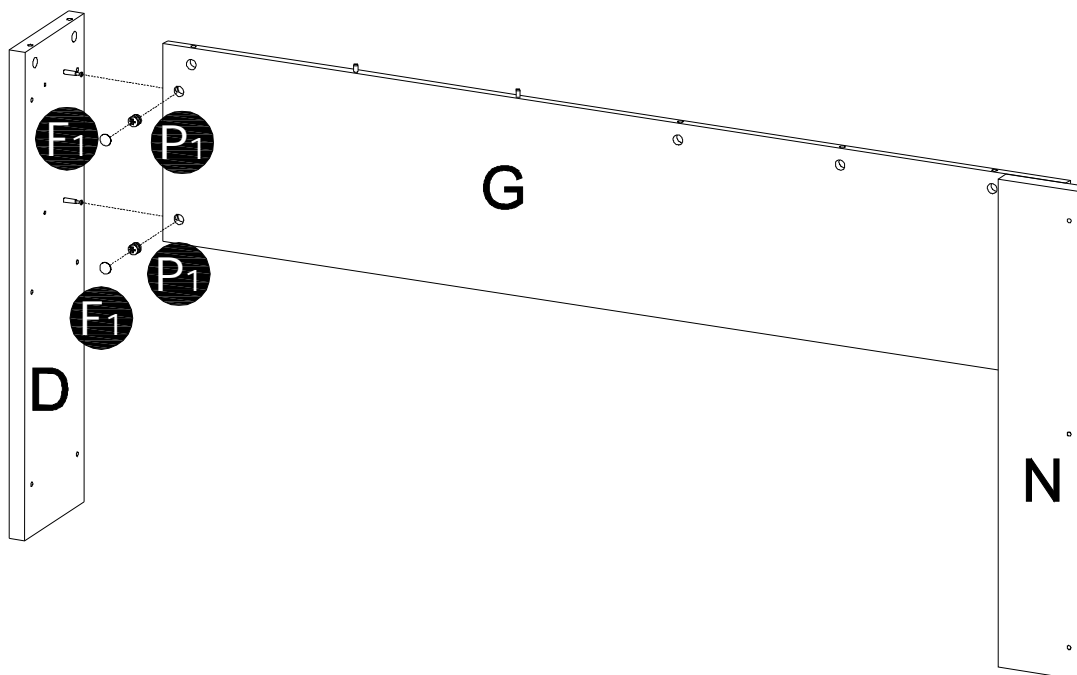
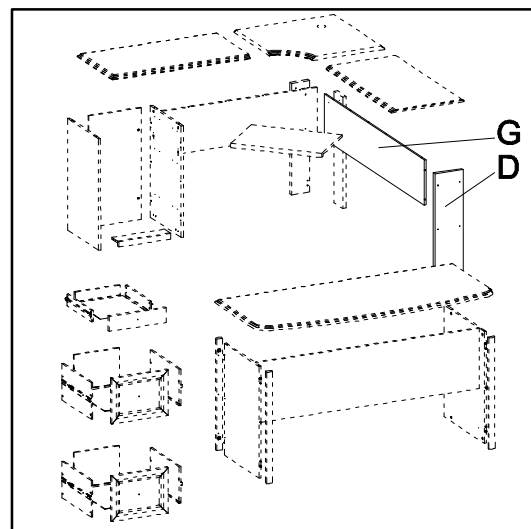



# STEP 56

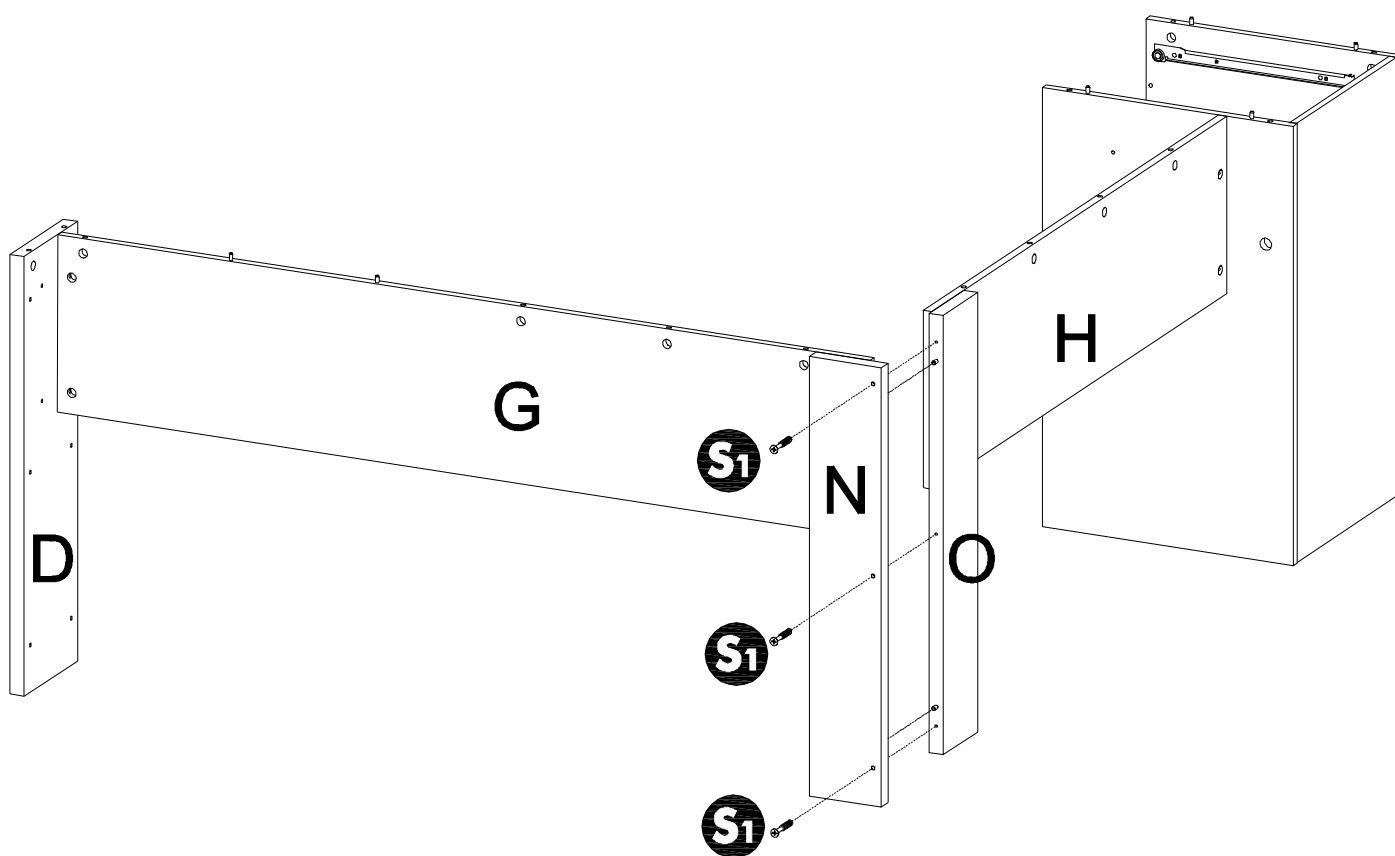
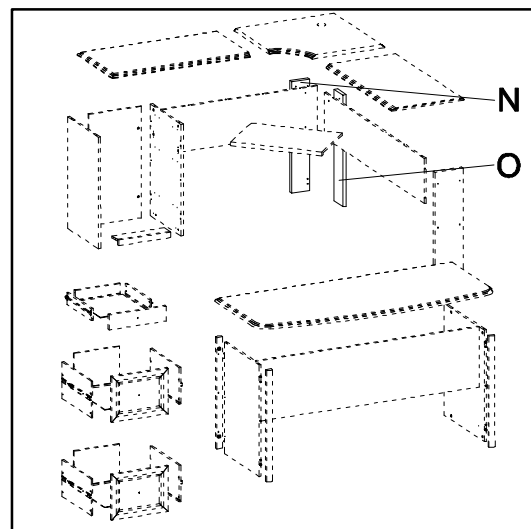
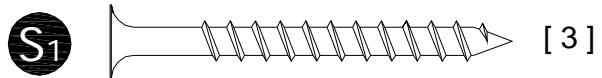

# STEP 57

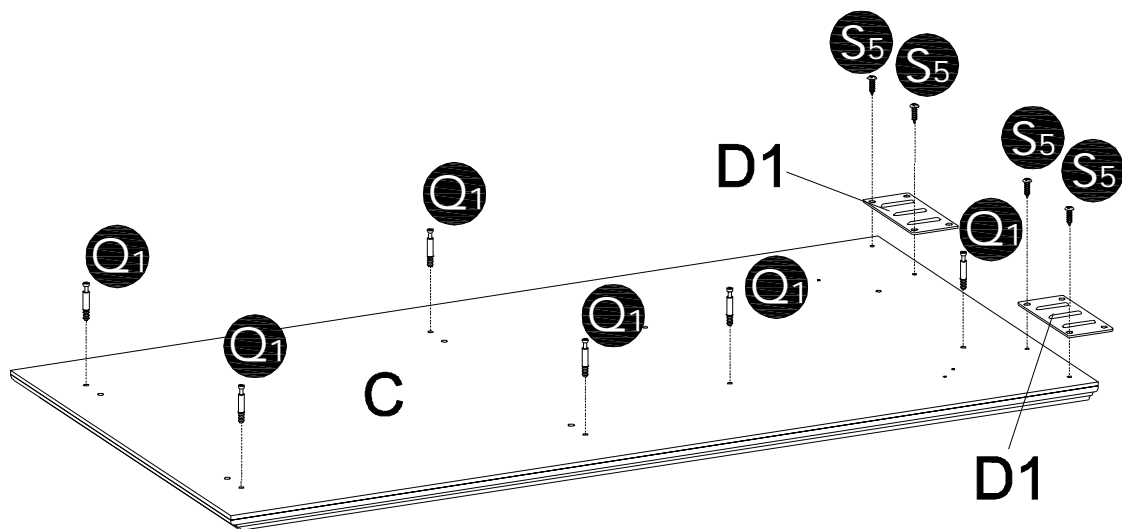
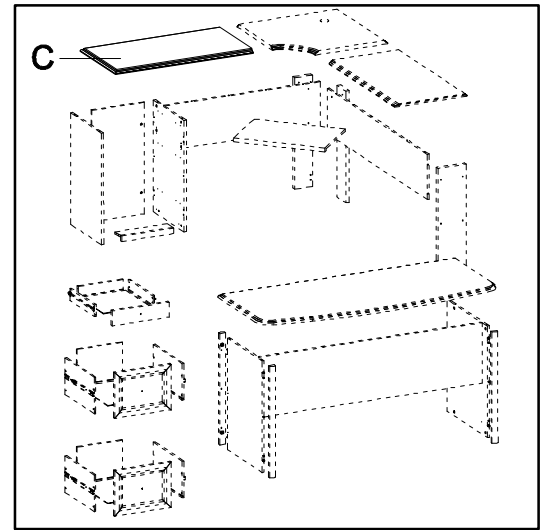
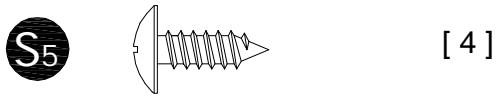
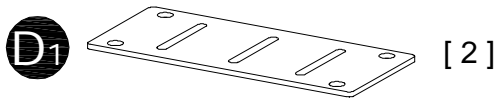
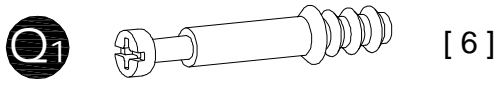



# STEP 59

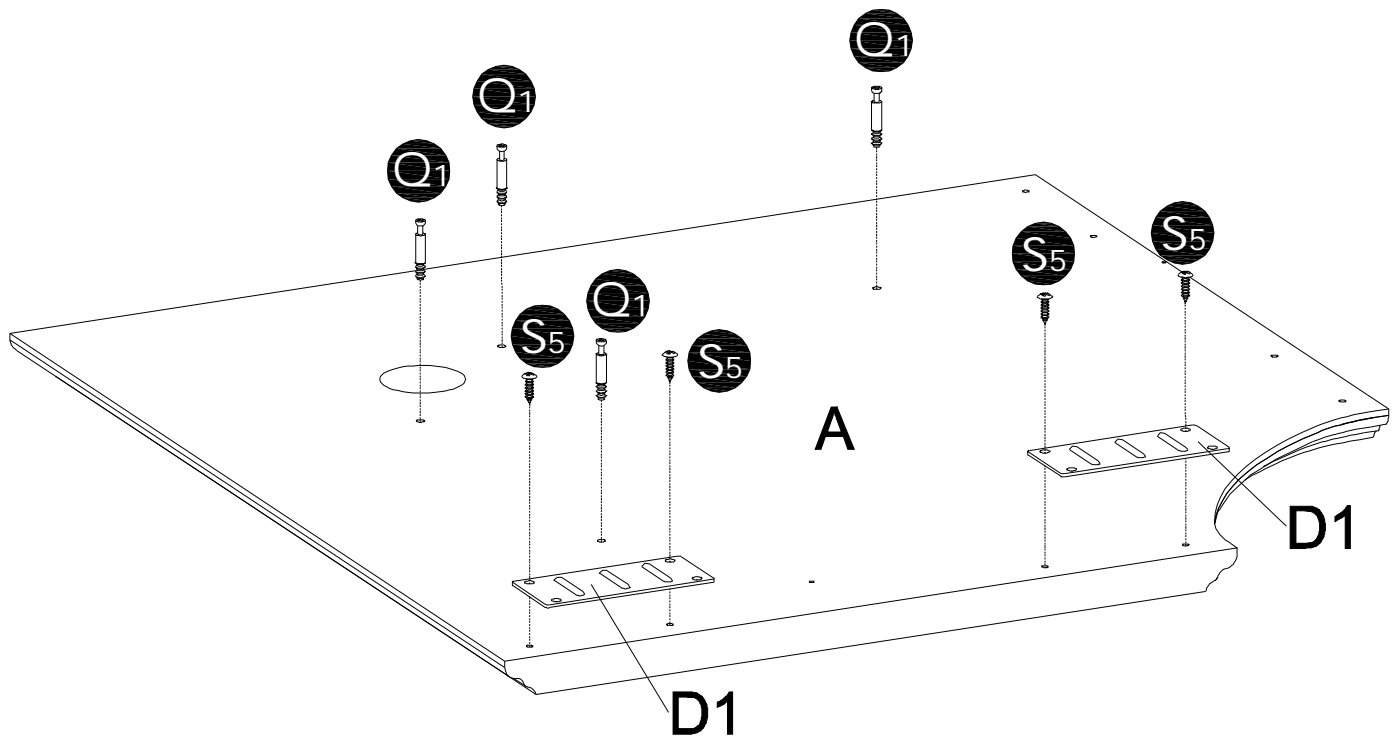
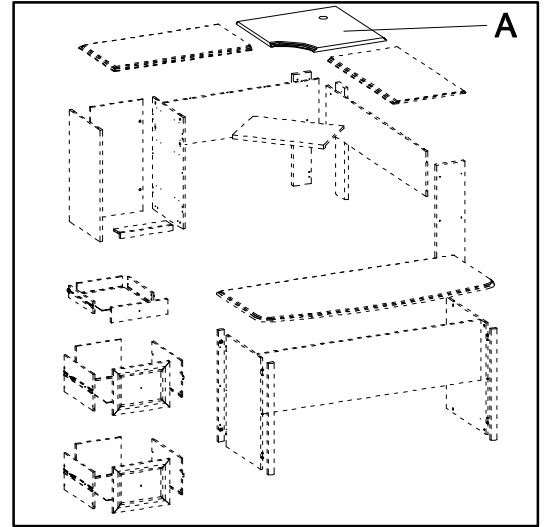
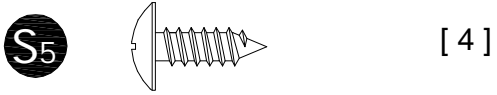
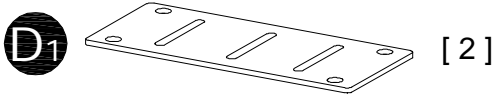
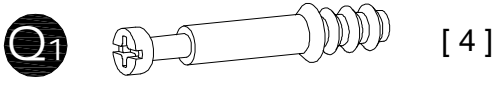

# STEP 60

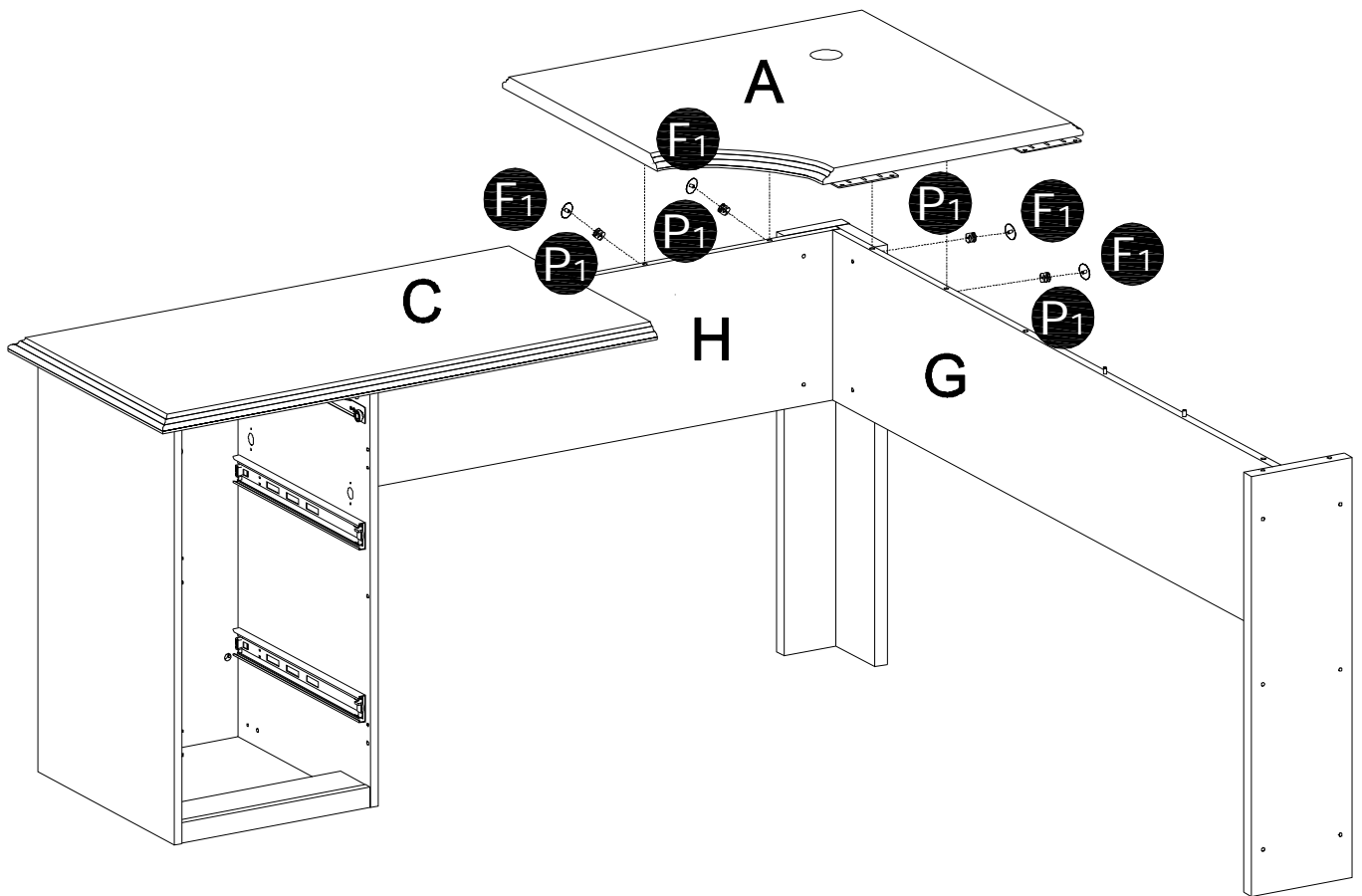
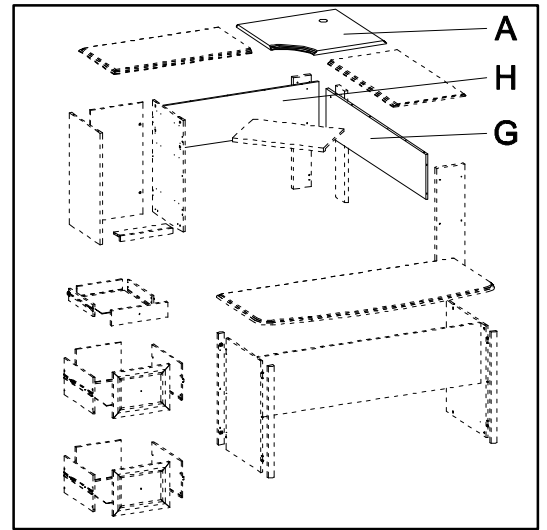
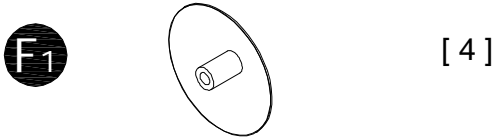
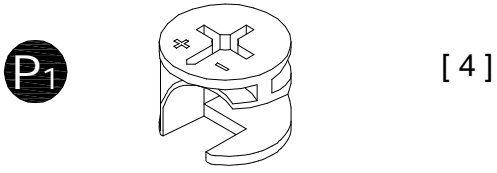

# STEP 61

S<sub>5</sub>

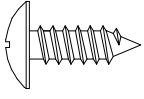

[ 4 ]

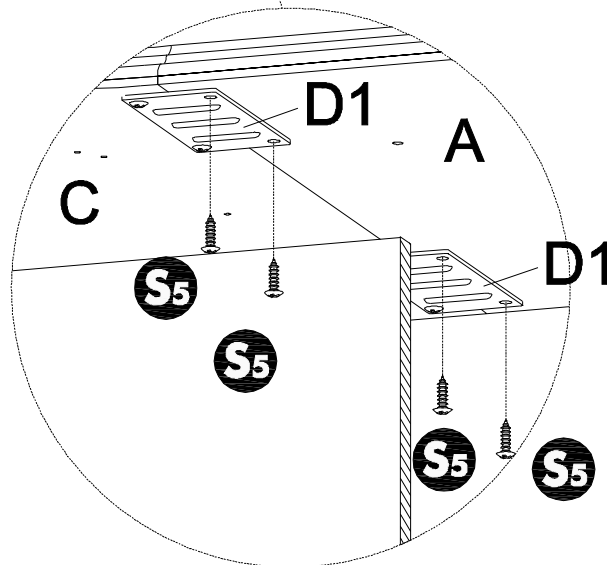
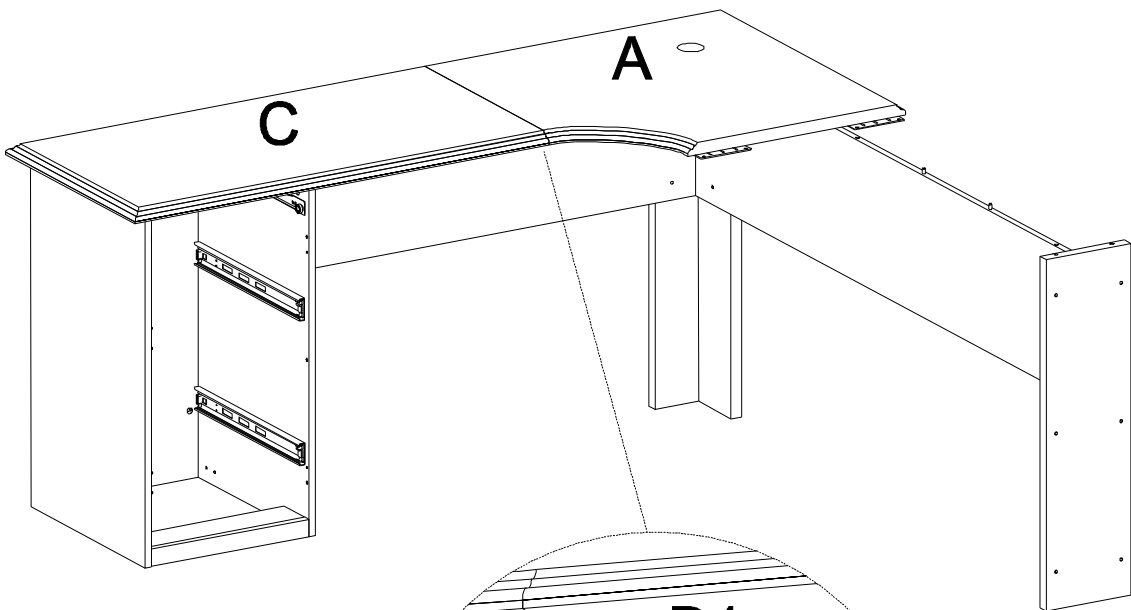
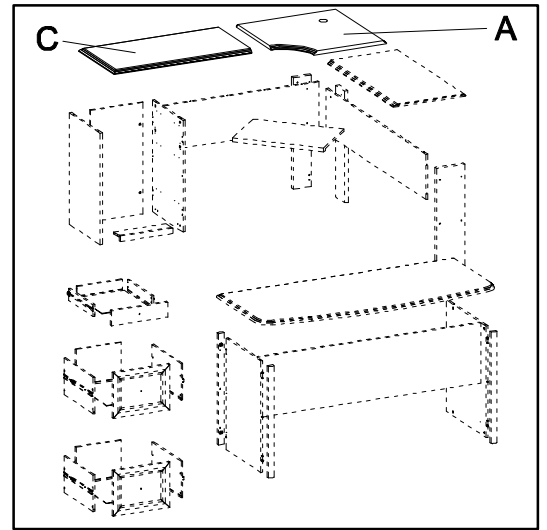

# STEP 62

Q1

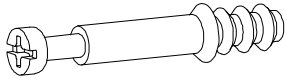

[ 4 ]

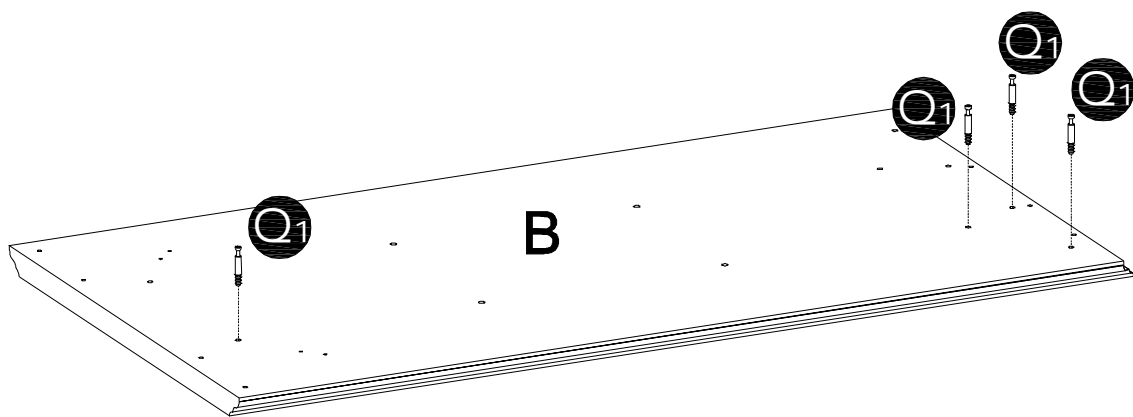
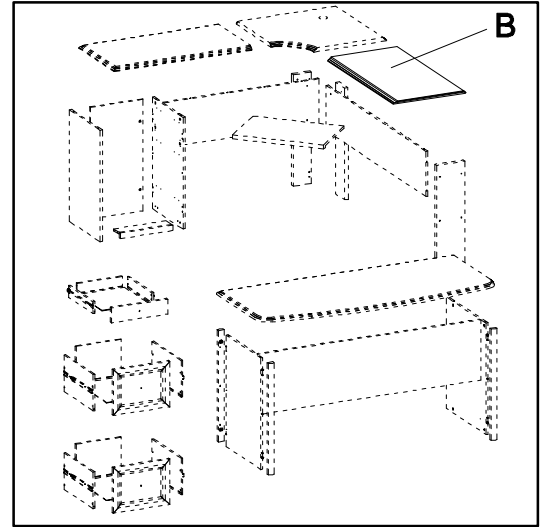

# STEP 63

P<sub>1</sub>

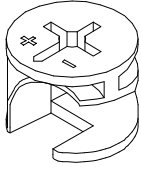

[ 4 ]

F<sub>1</sub>

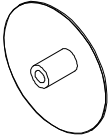

[ 4 ]

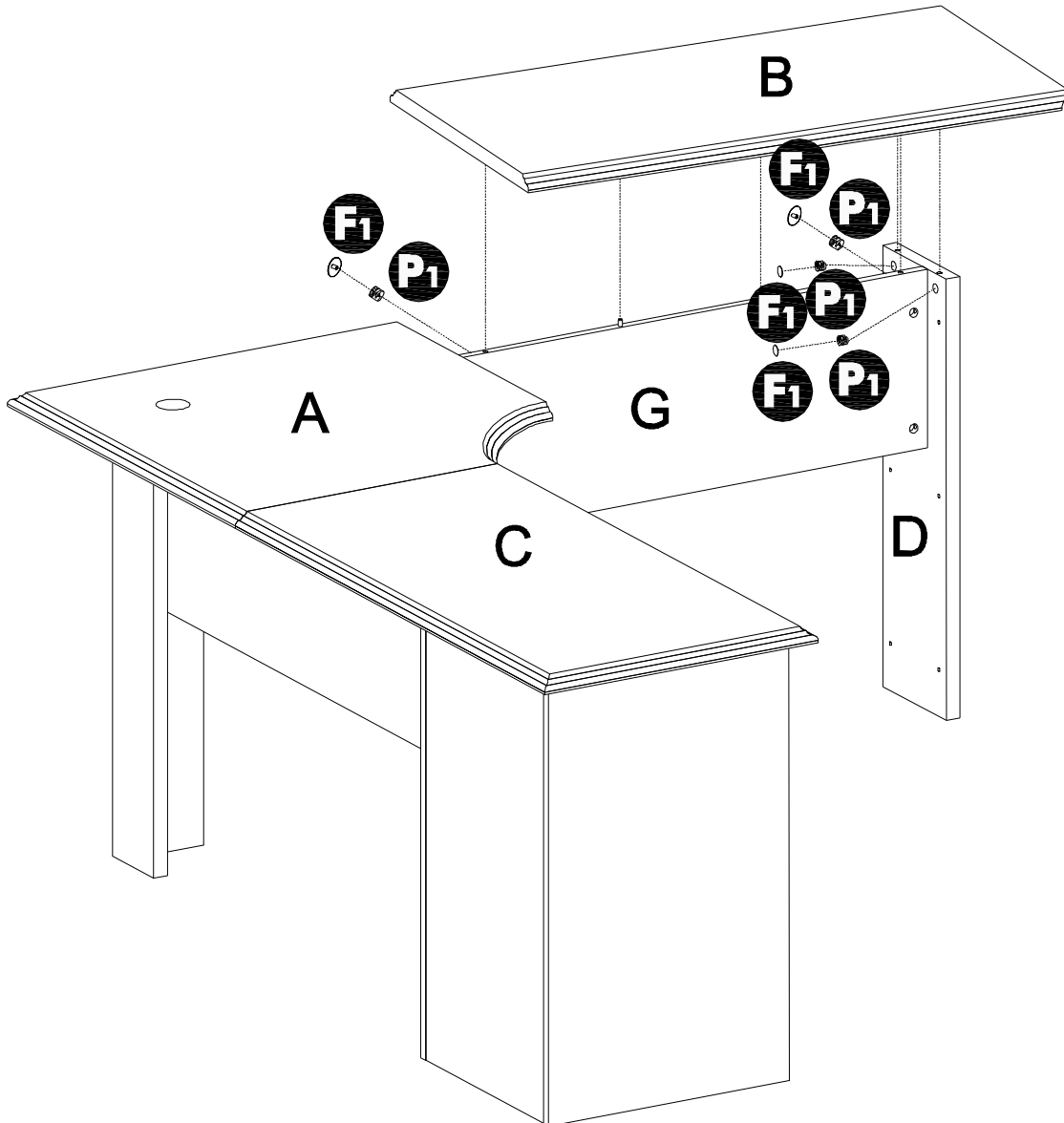
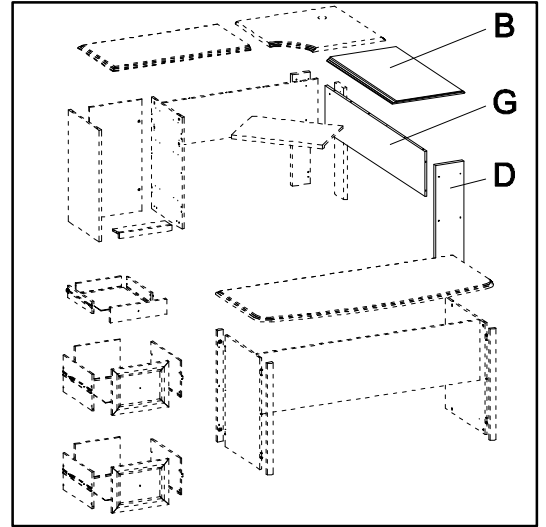



# STEP 64

S<sub>5</sub>

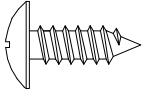

[ 4 ]

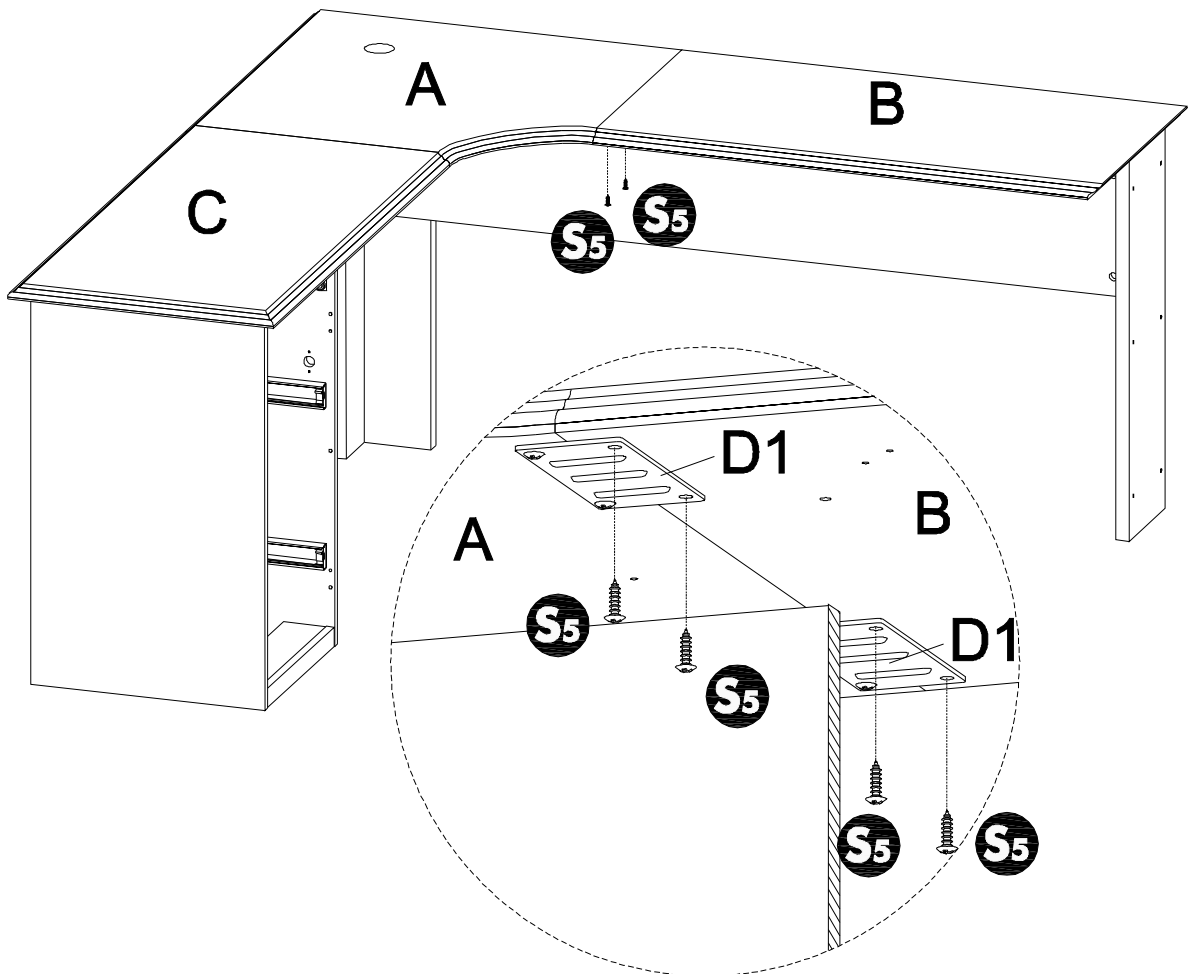
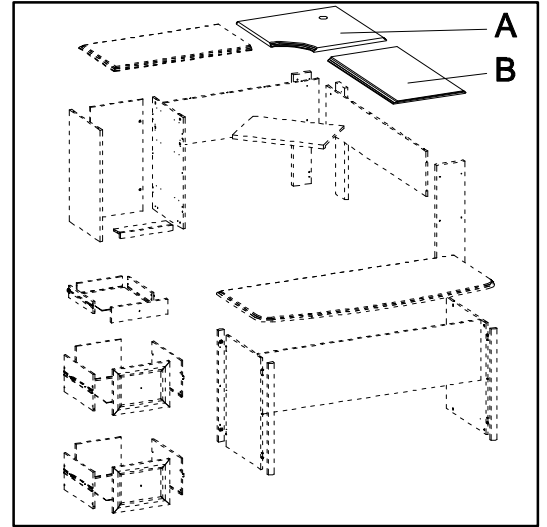

# STEP 65

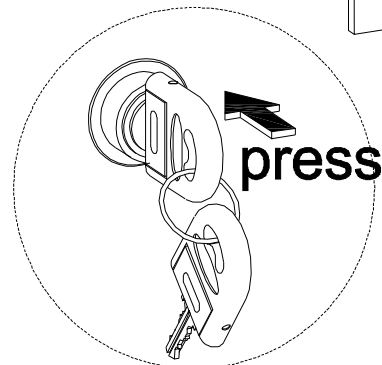
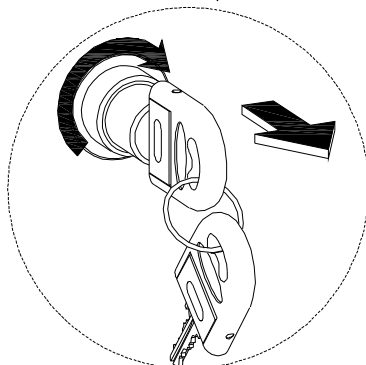
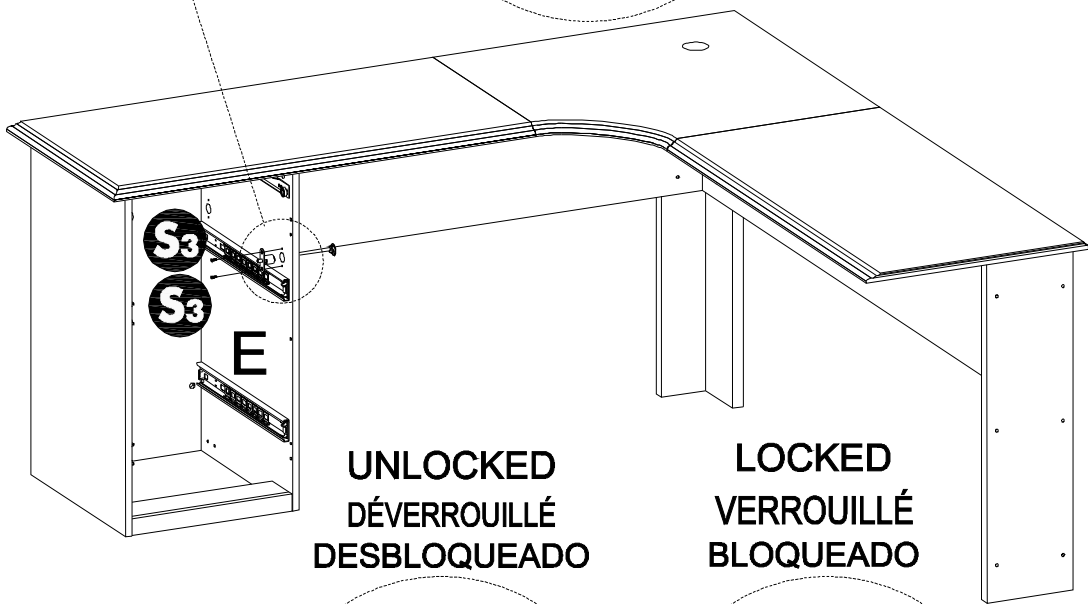
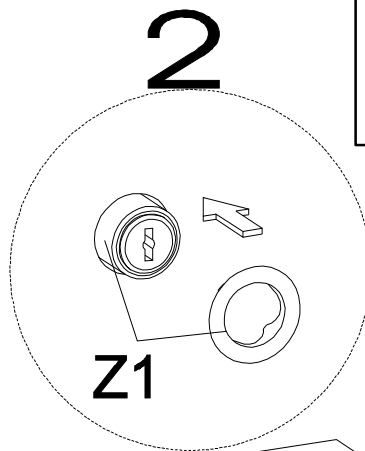
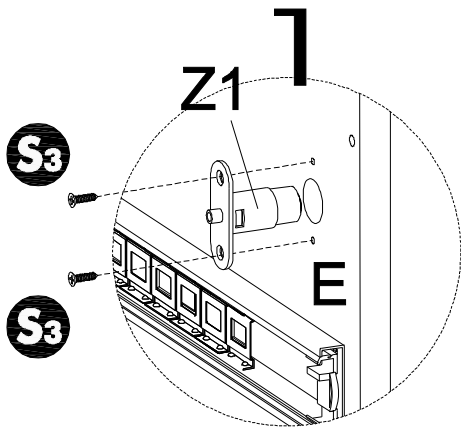
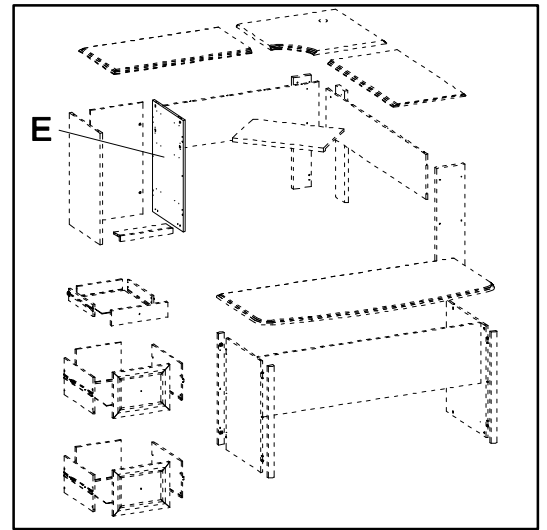
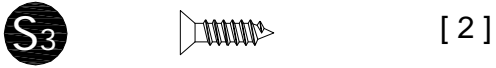
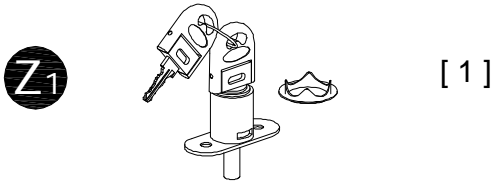

# STEP 66

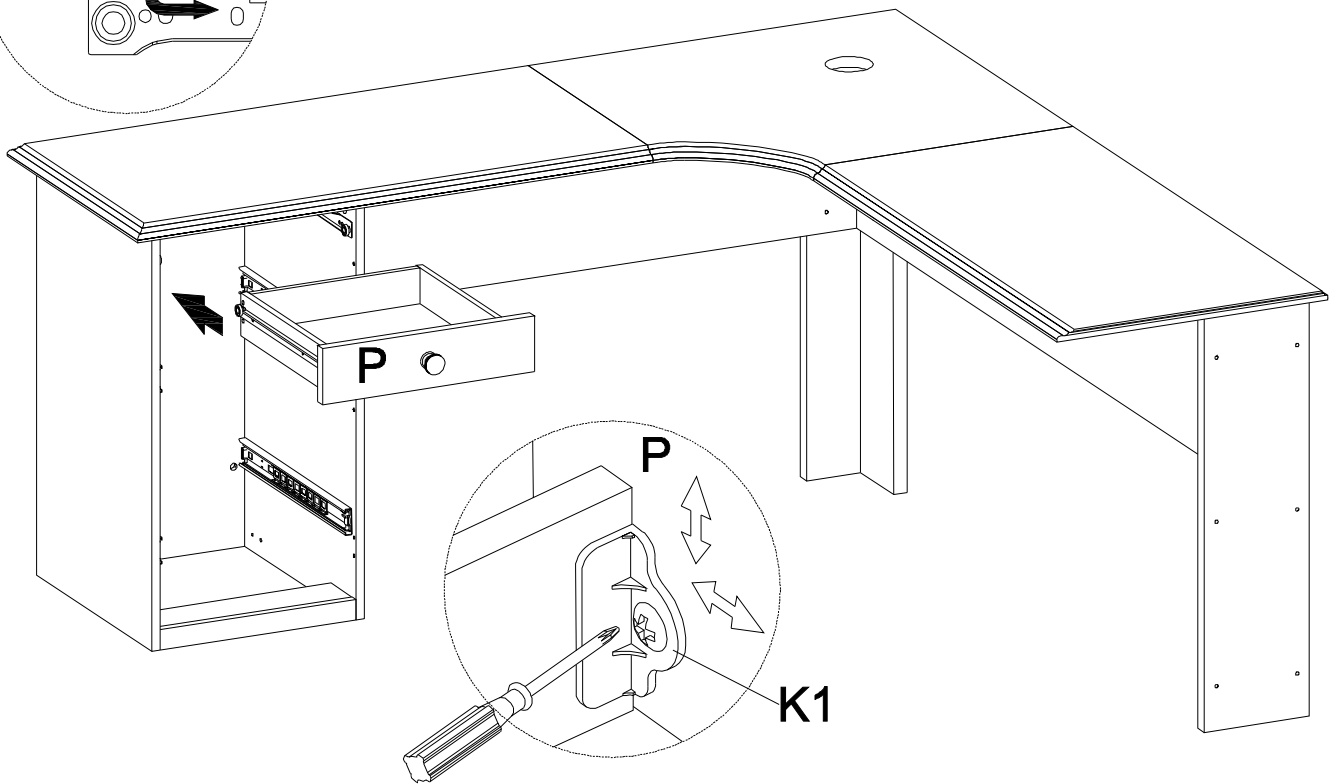
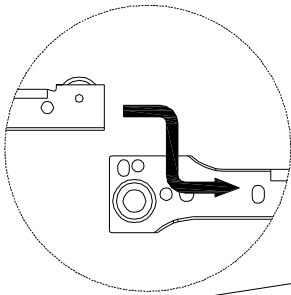
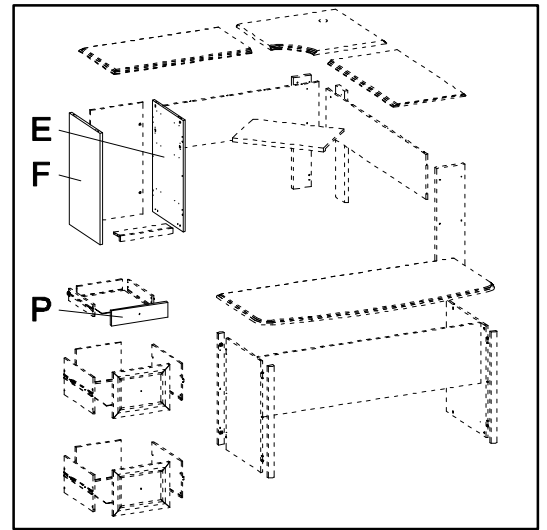

# STEP 67

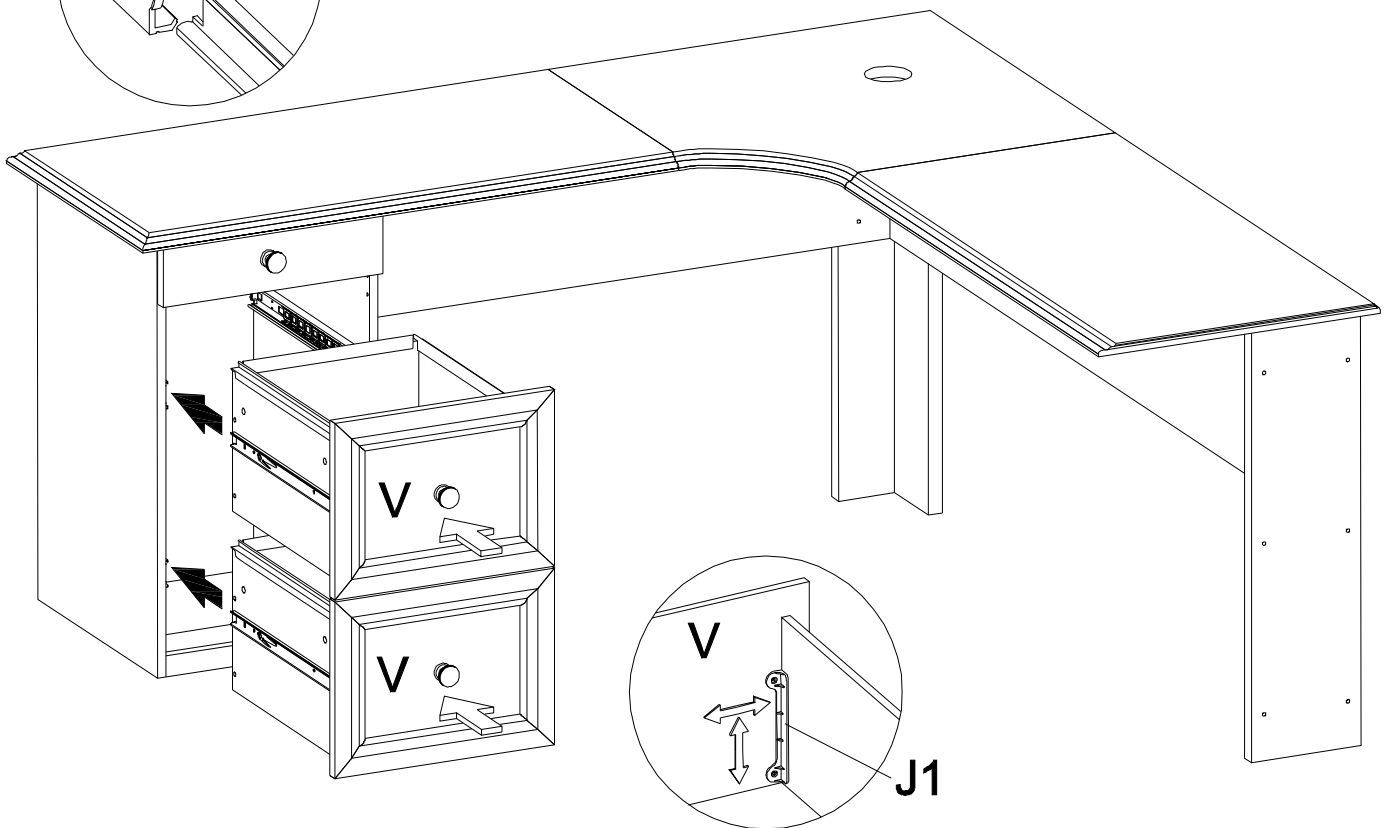
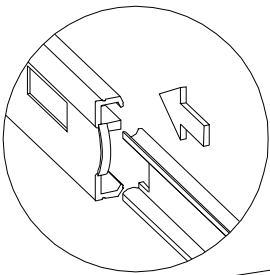
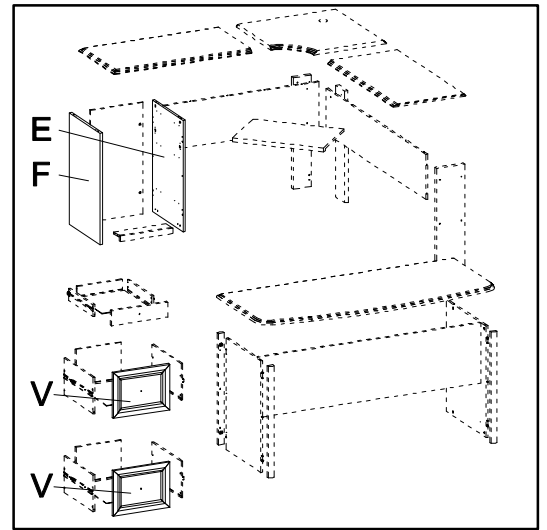

# STEP 68

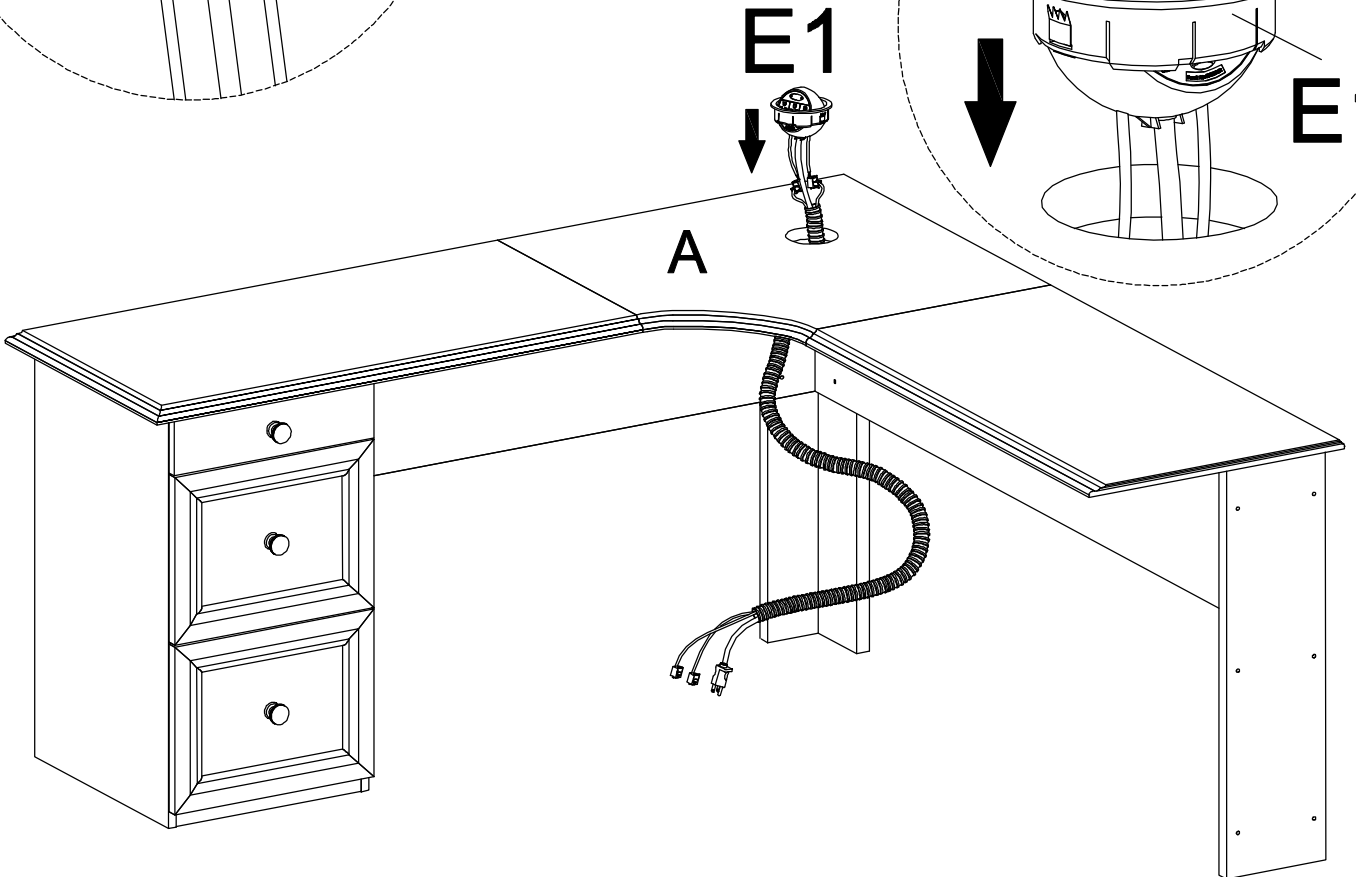
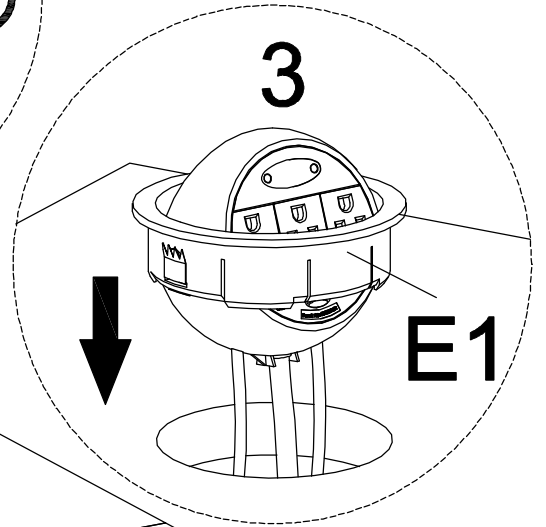
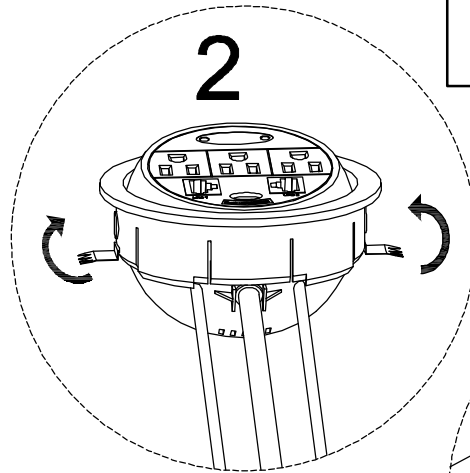
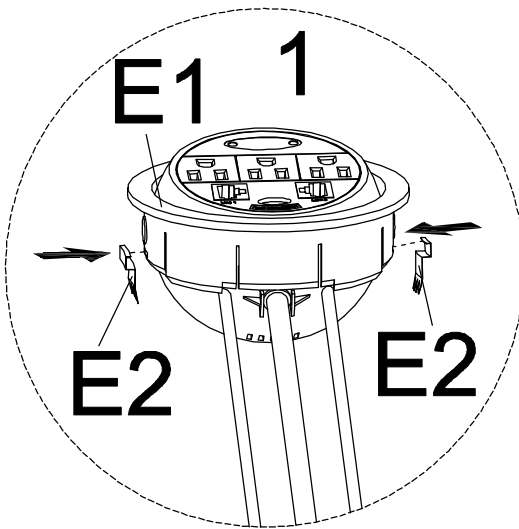
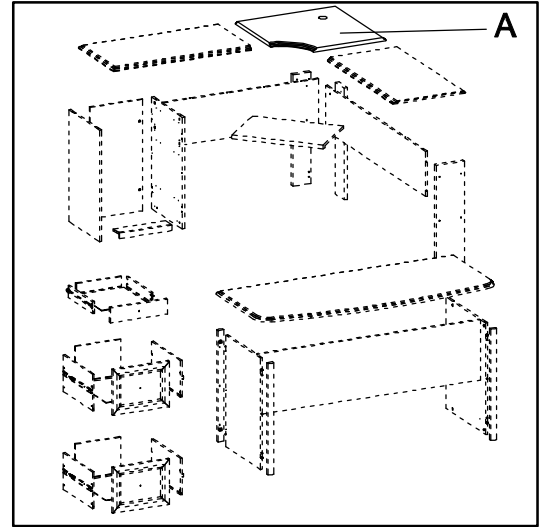
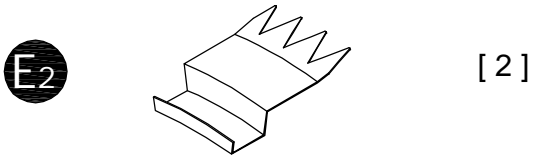
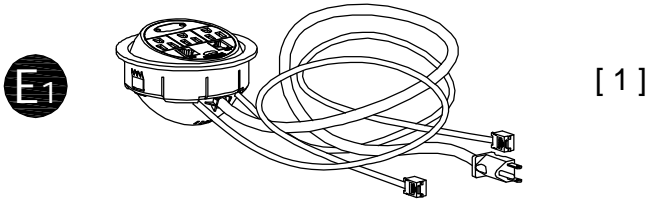

# STEP 69

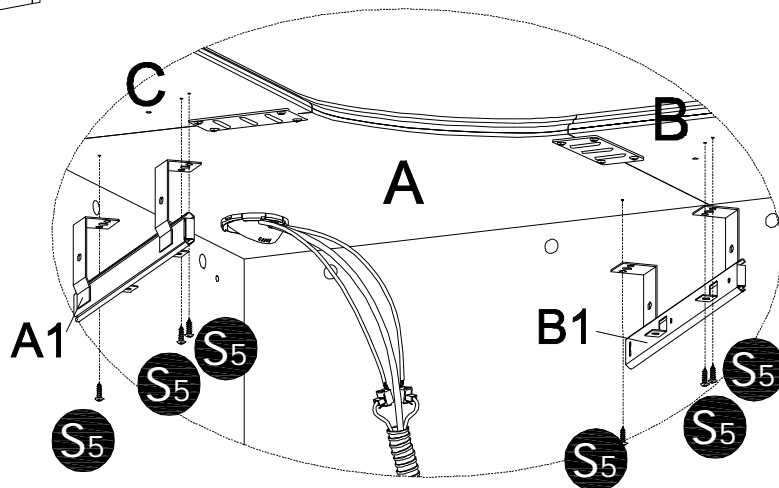
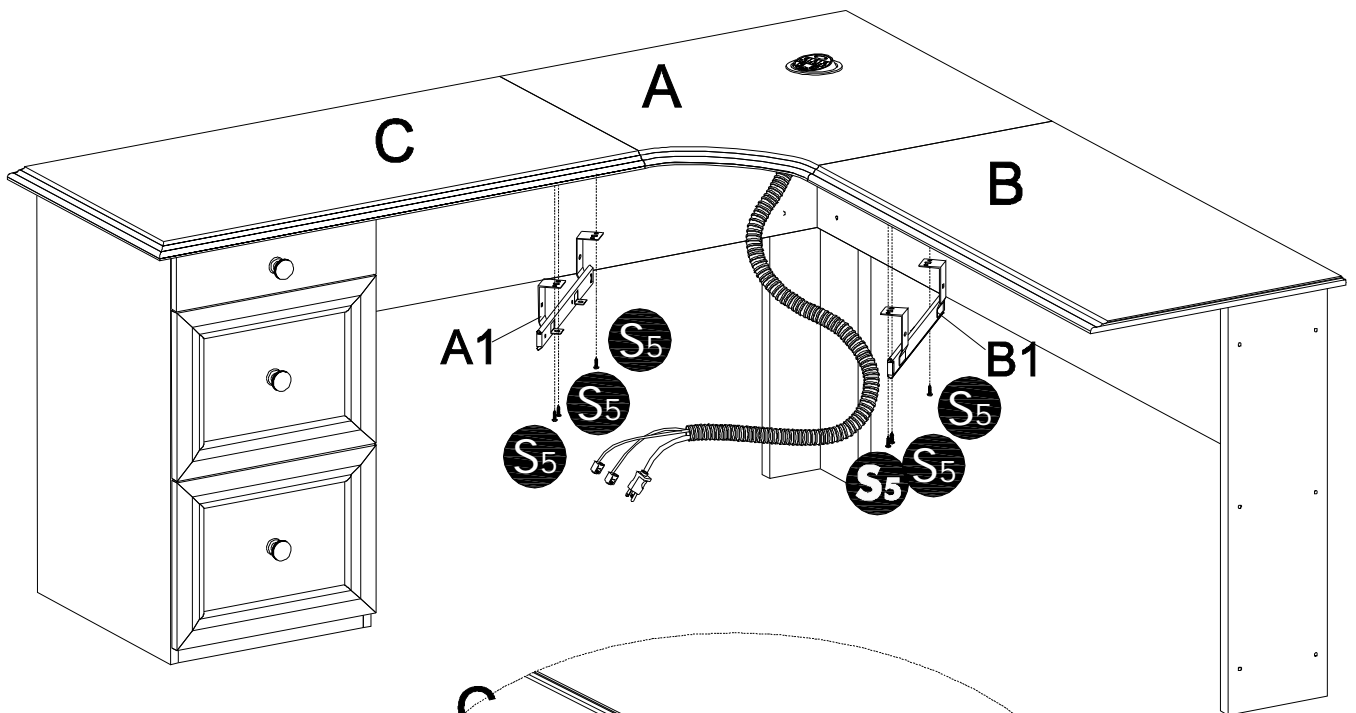
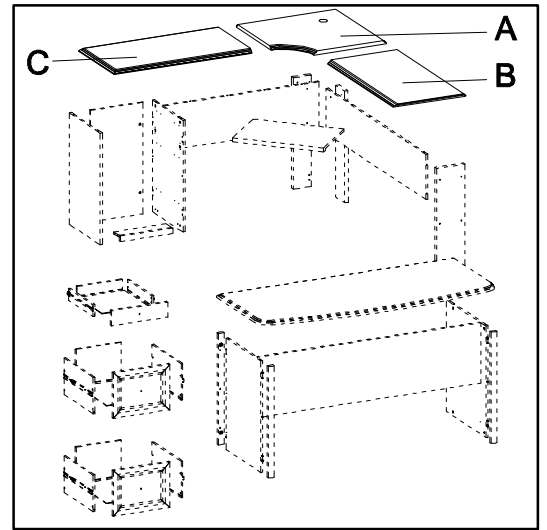
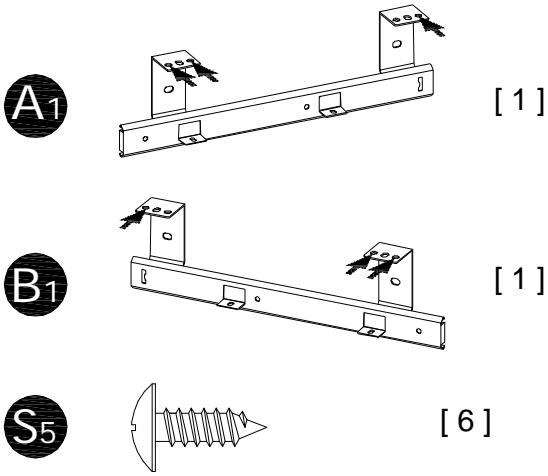

# STEP 70

S4

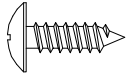

[ 4 ]

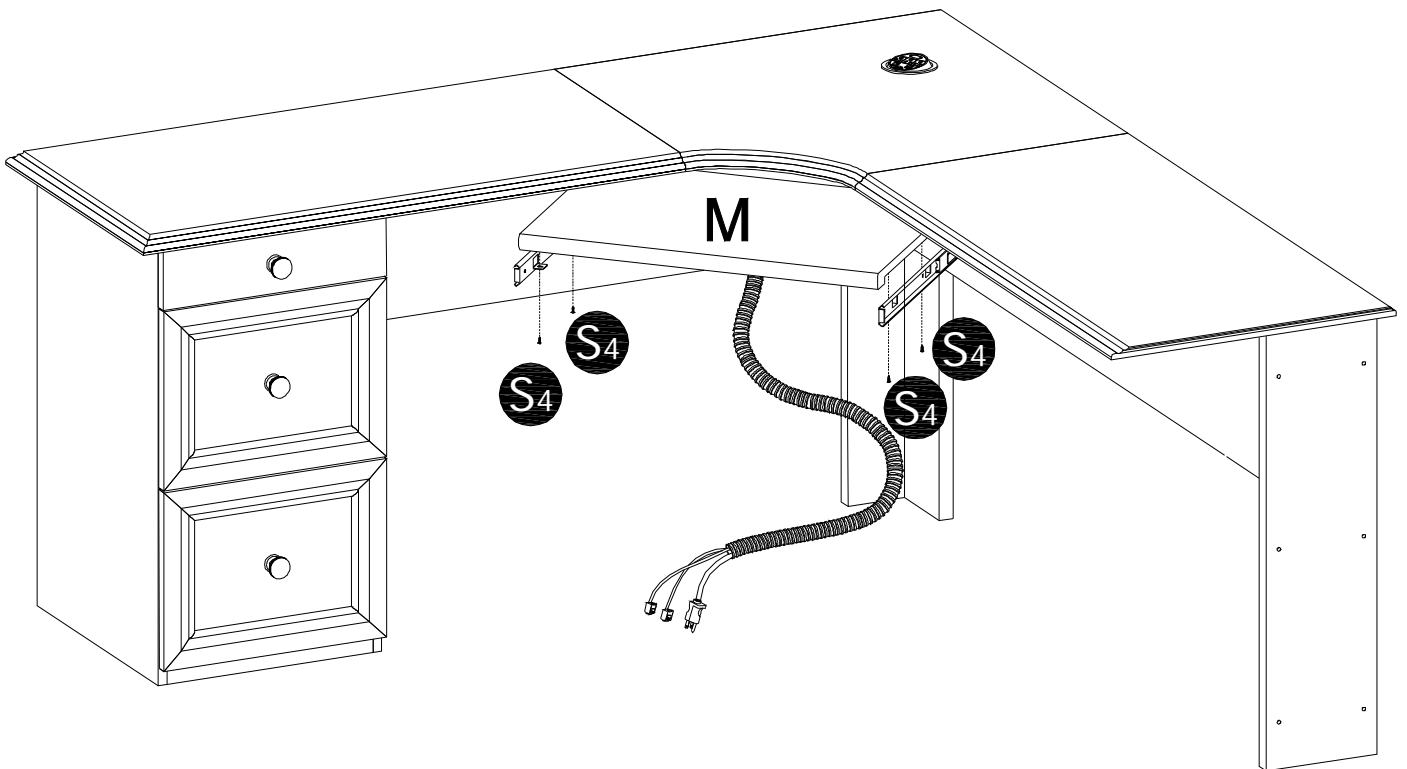
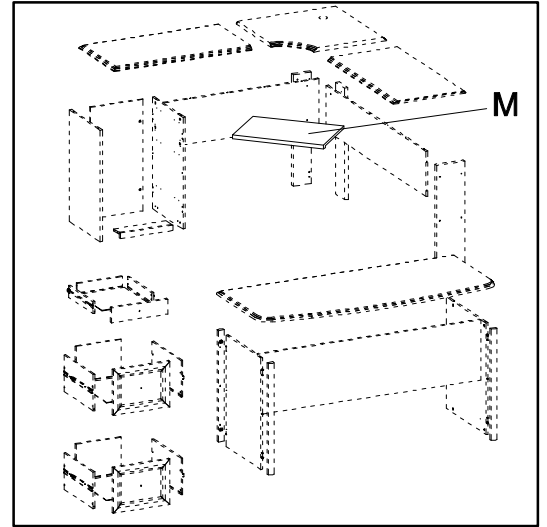

# STEP 71

R<sub>1</sub>

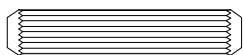

[2]

M<sub>1</sub>

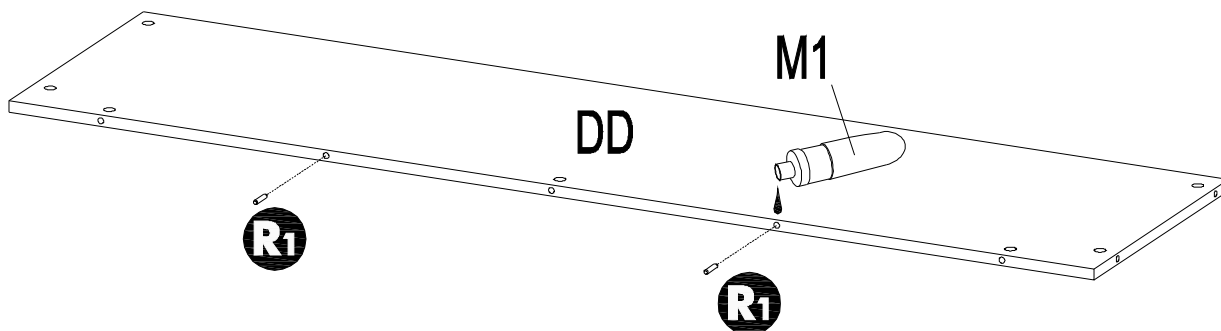
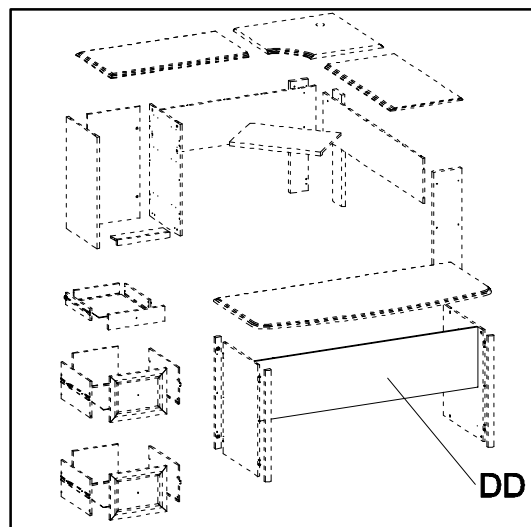
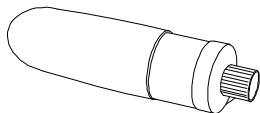



# STEP 72

G1



[ 4 ]

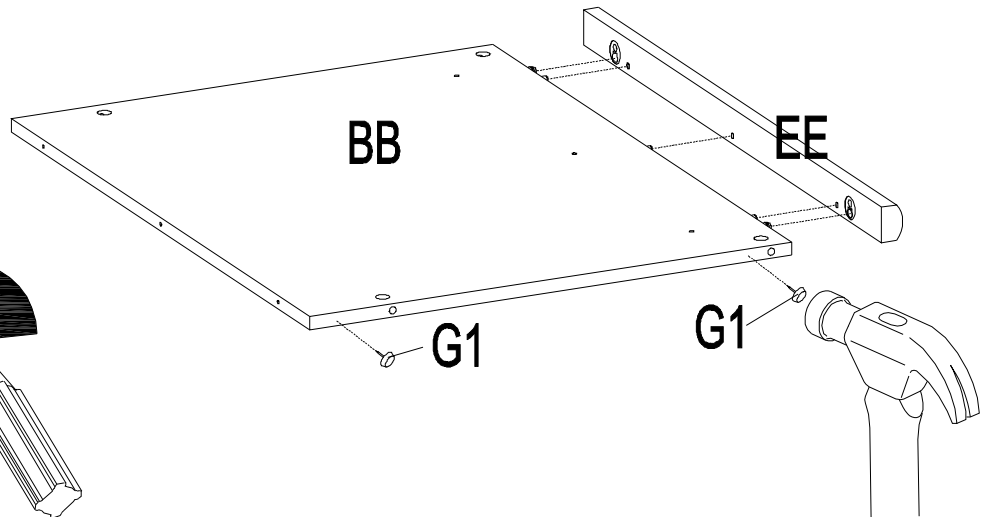
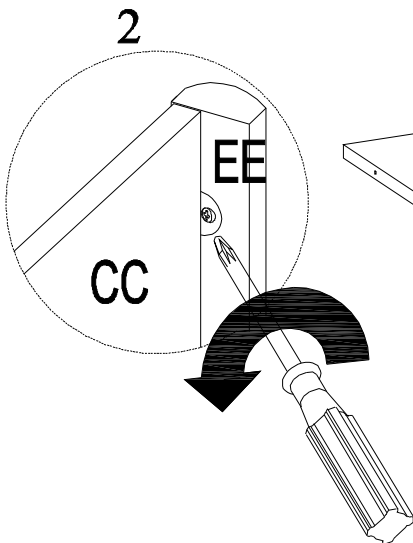
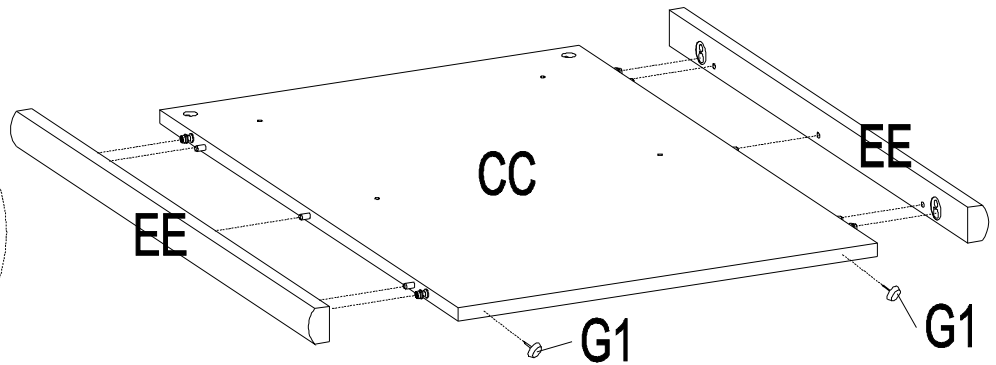
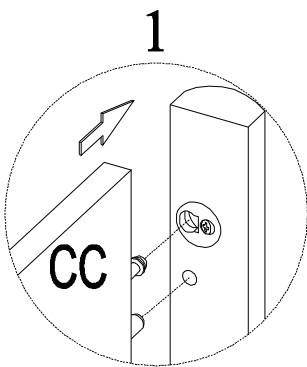
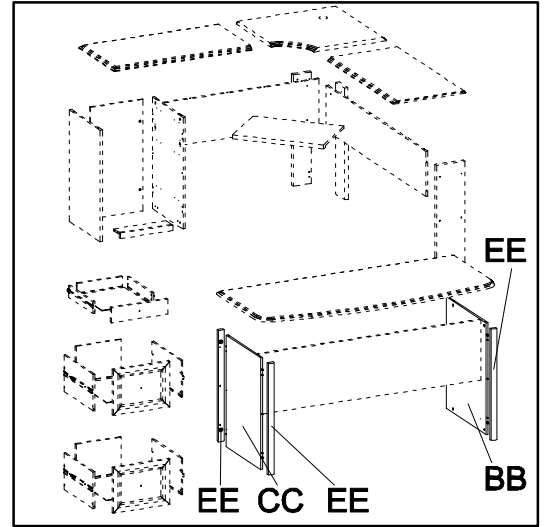

# STEP 73

**Q1**  [4]

**L1**  [2]

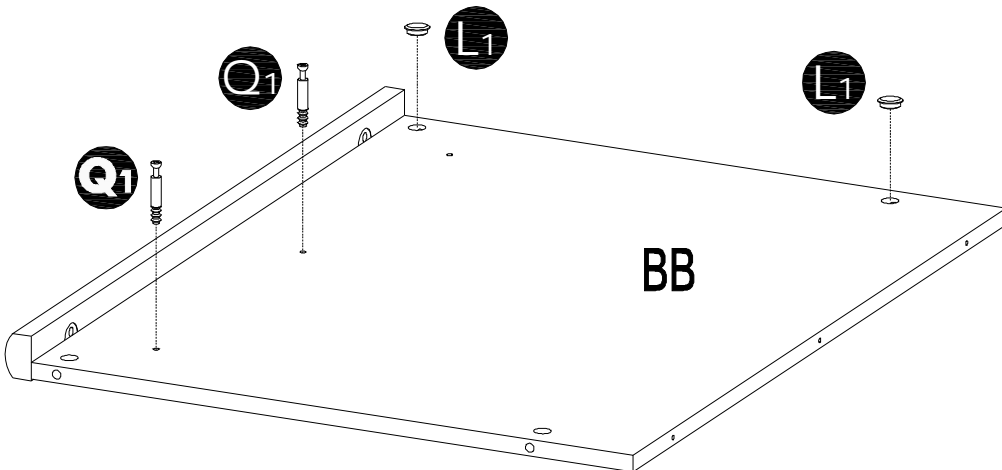
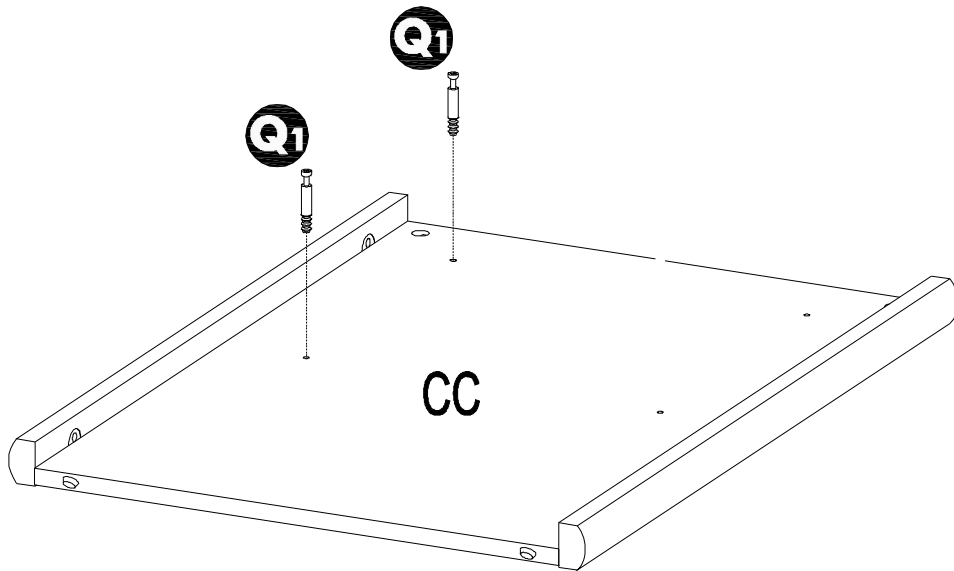
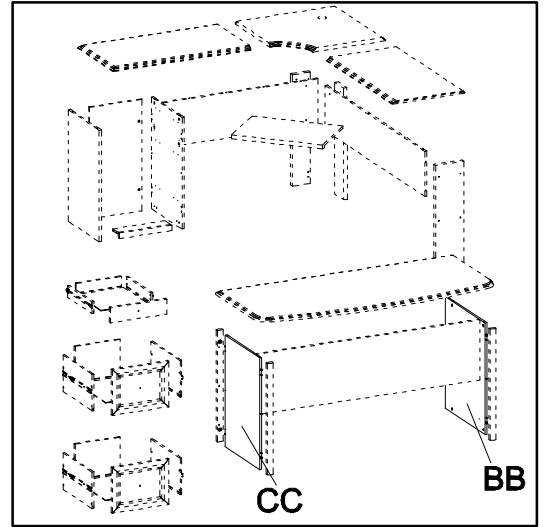

# STEP 74

P1

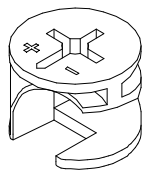

[2]

F1

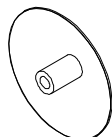

[2]

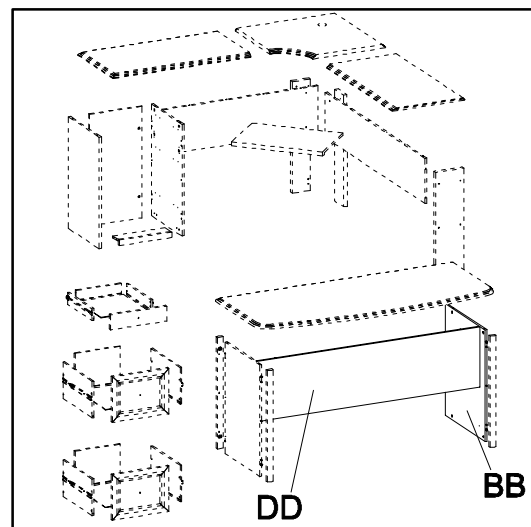

DD

BB

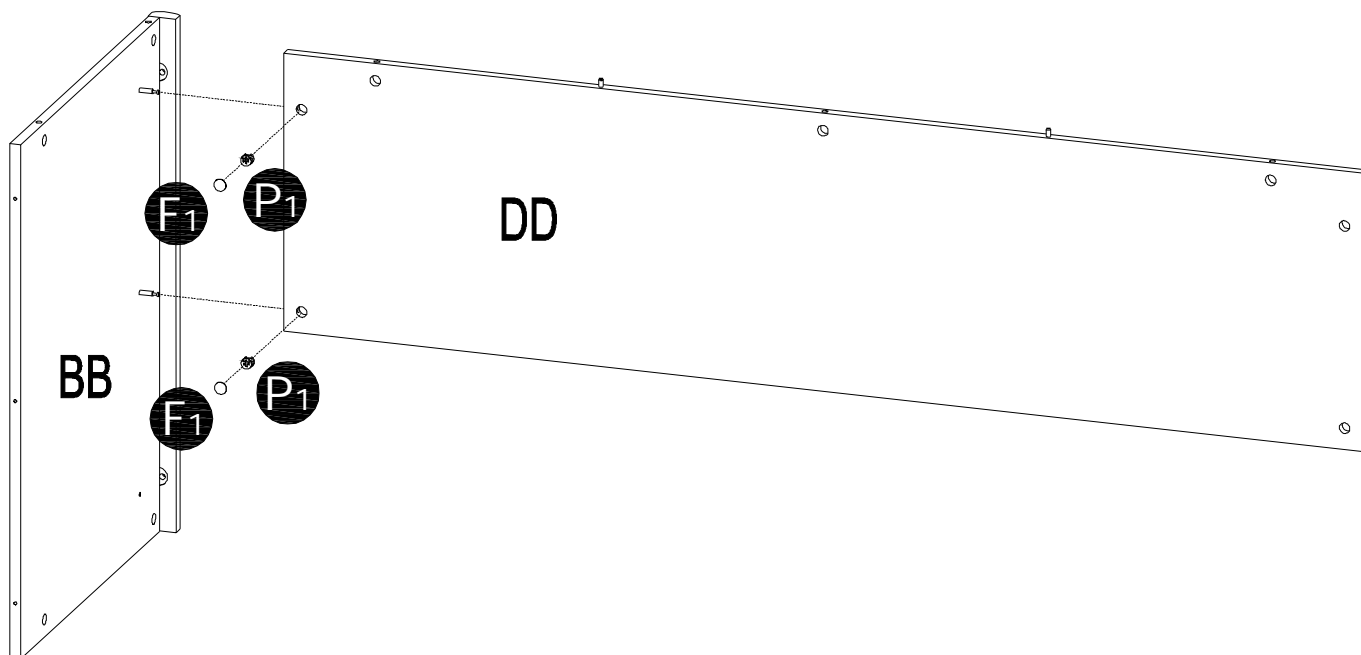

F1

P1

DD

BB

F1

P1

# STEP 75

P<sub>1</sub>

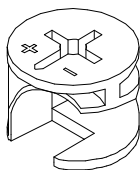

[2]

F<sub>1</sub>

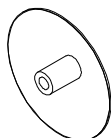

[2]

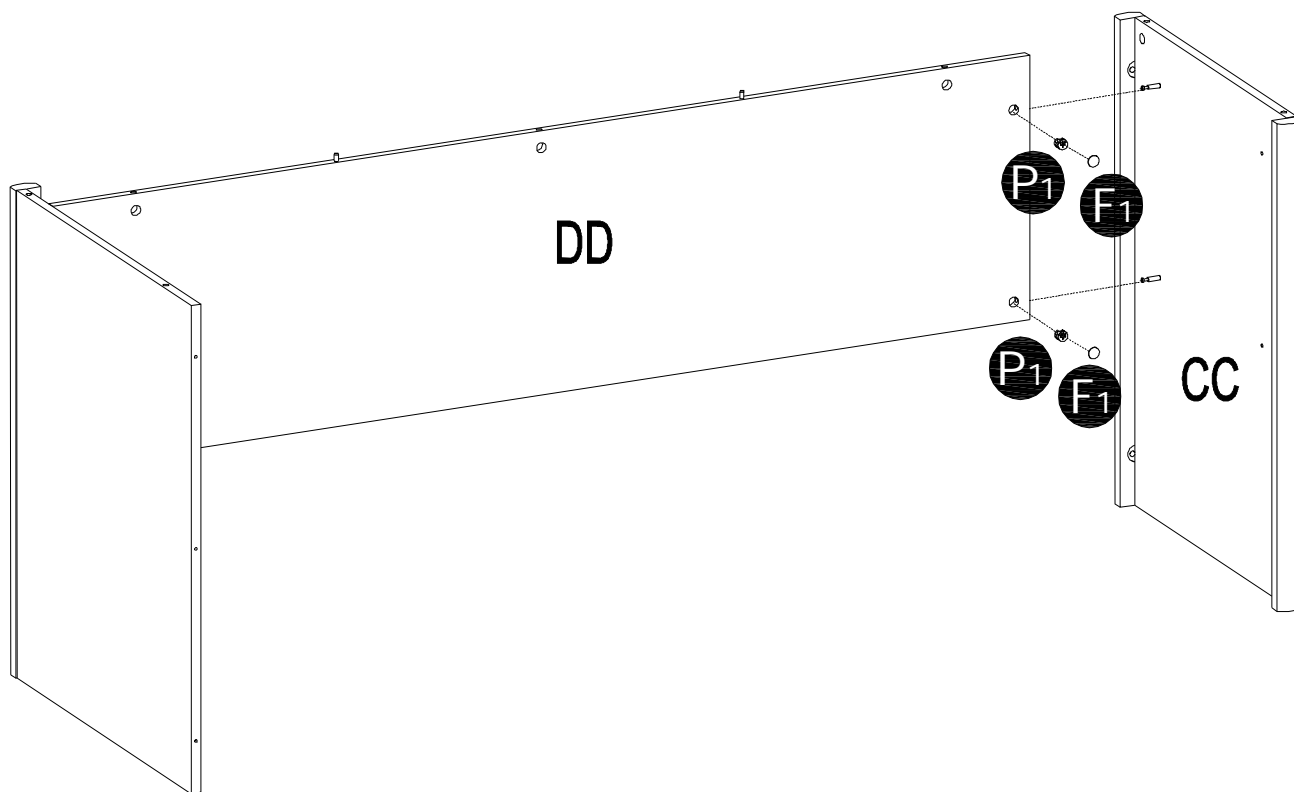
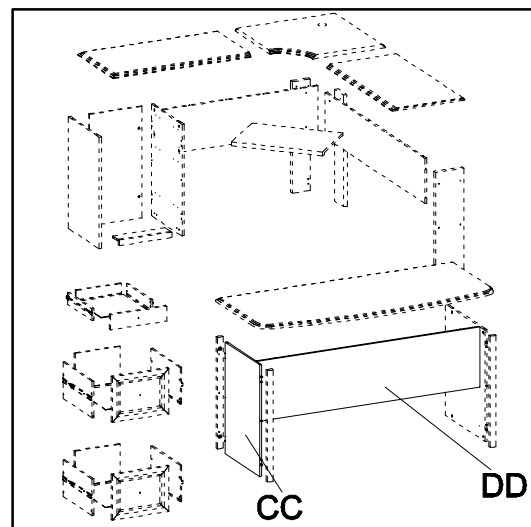

# STEP 76

Q1

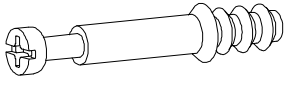

[7]

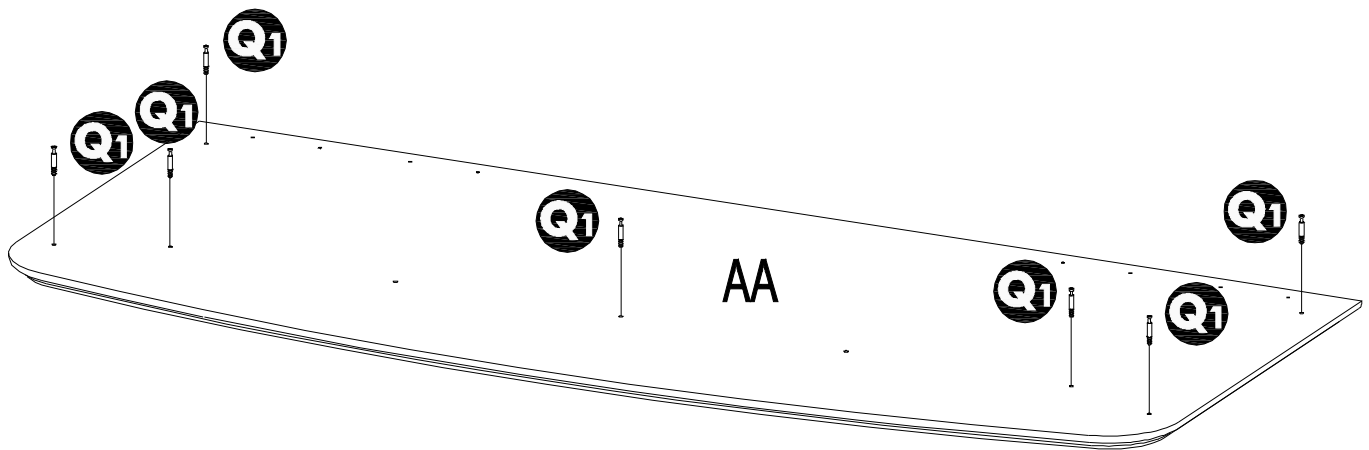
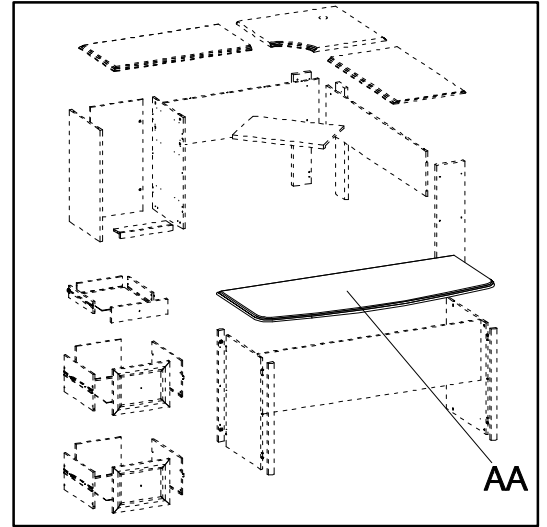

# STEP 77

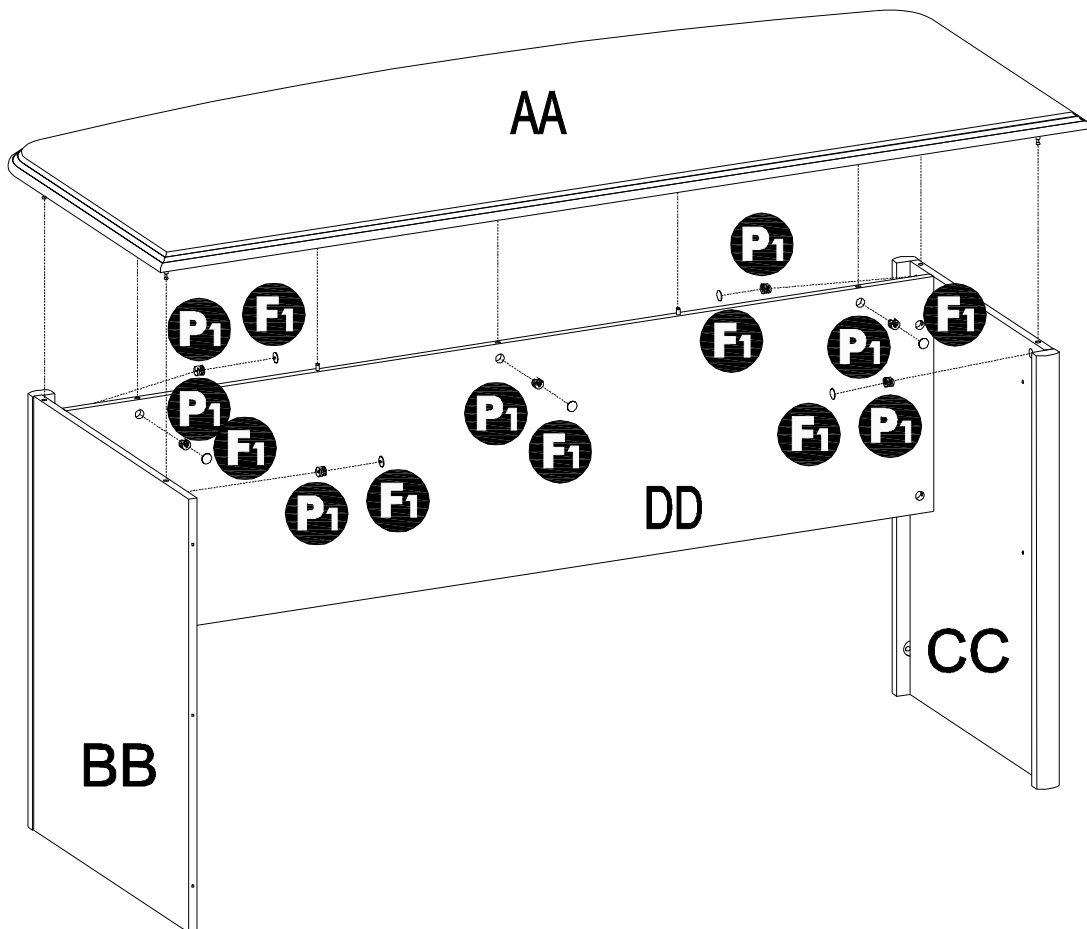
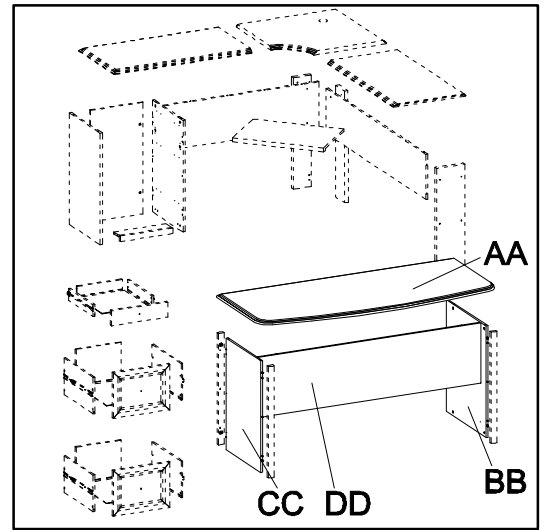
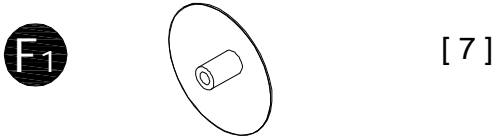
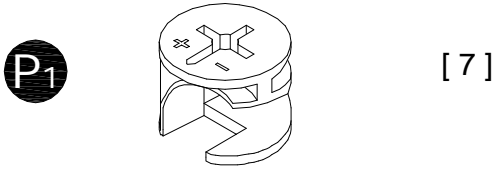

# STEP 78

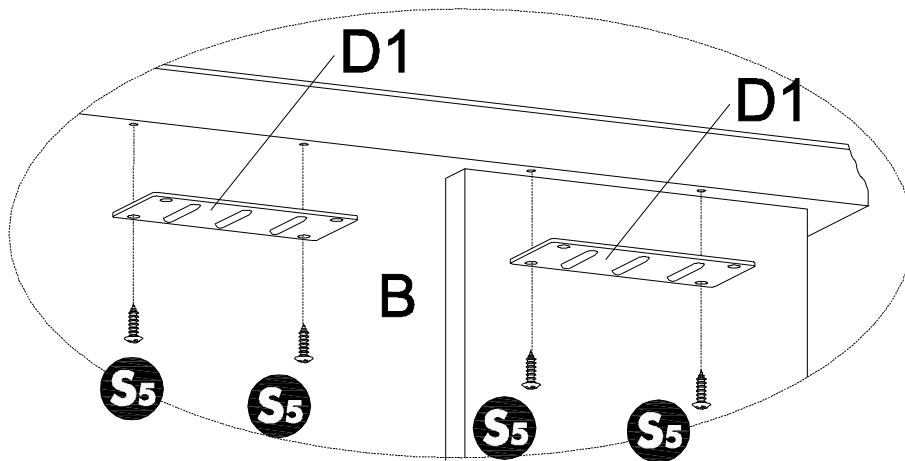
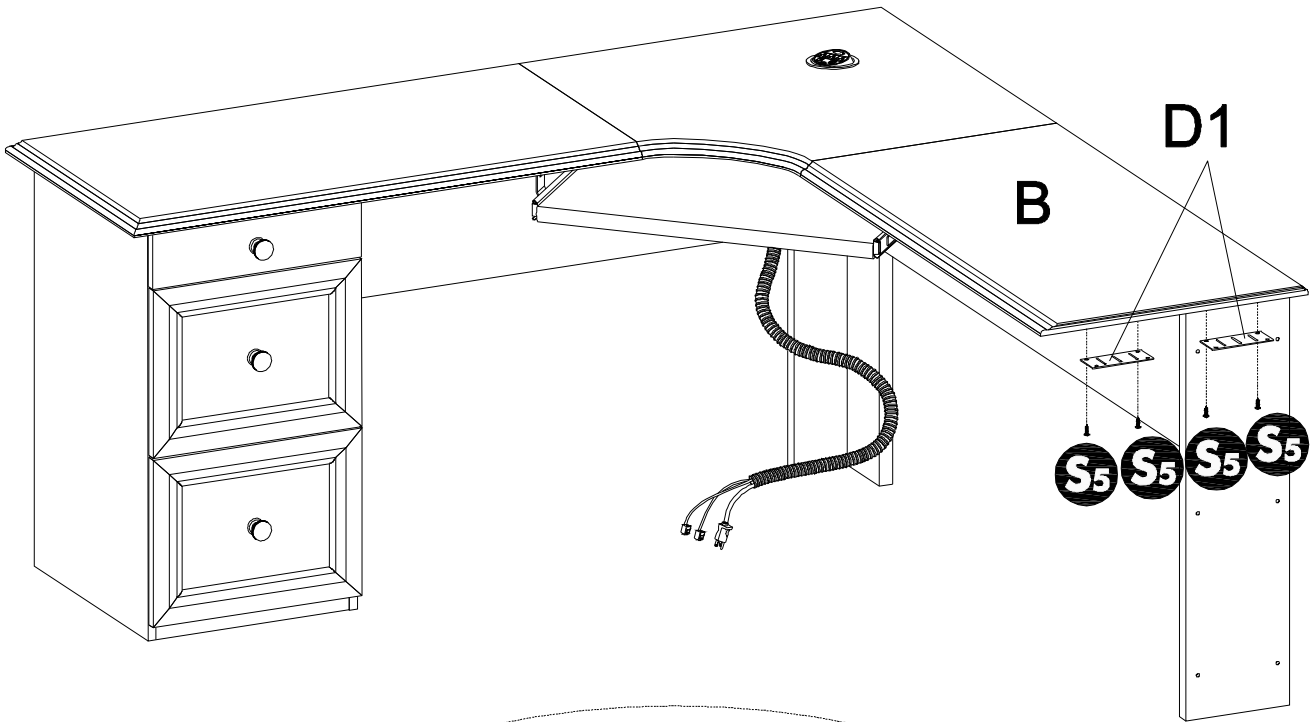
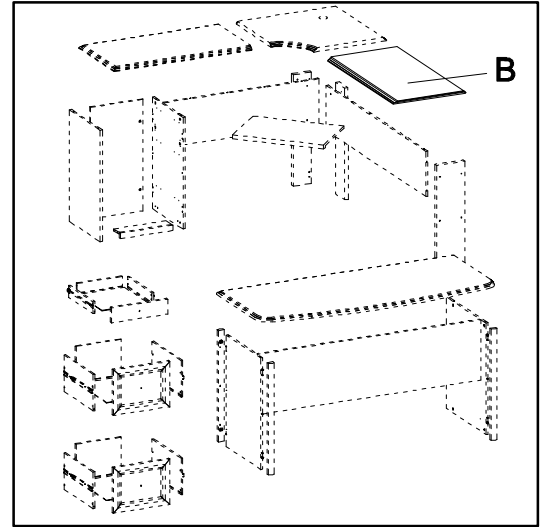
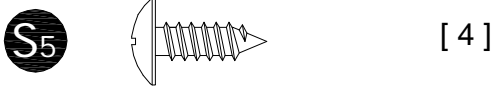
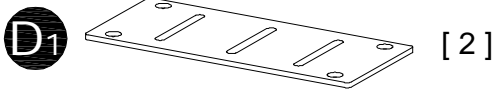

# STEP 79

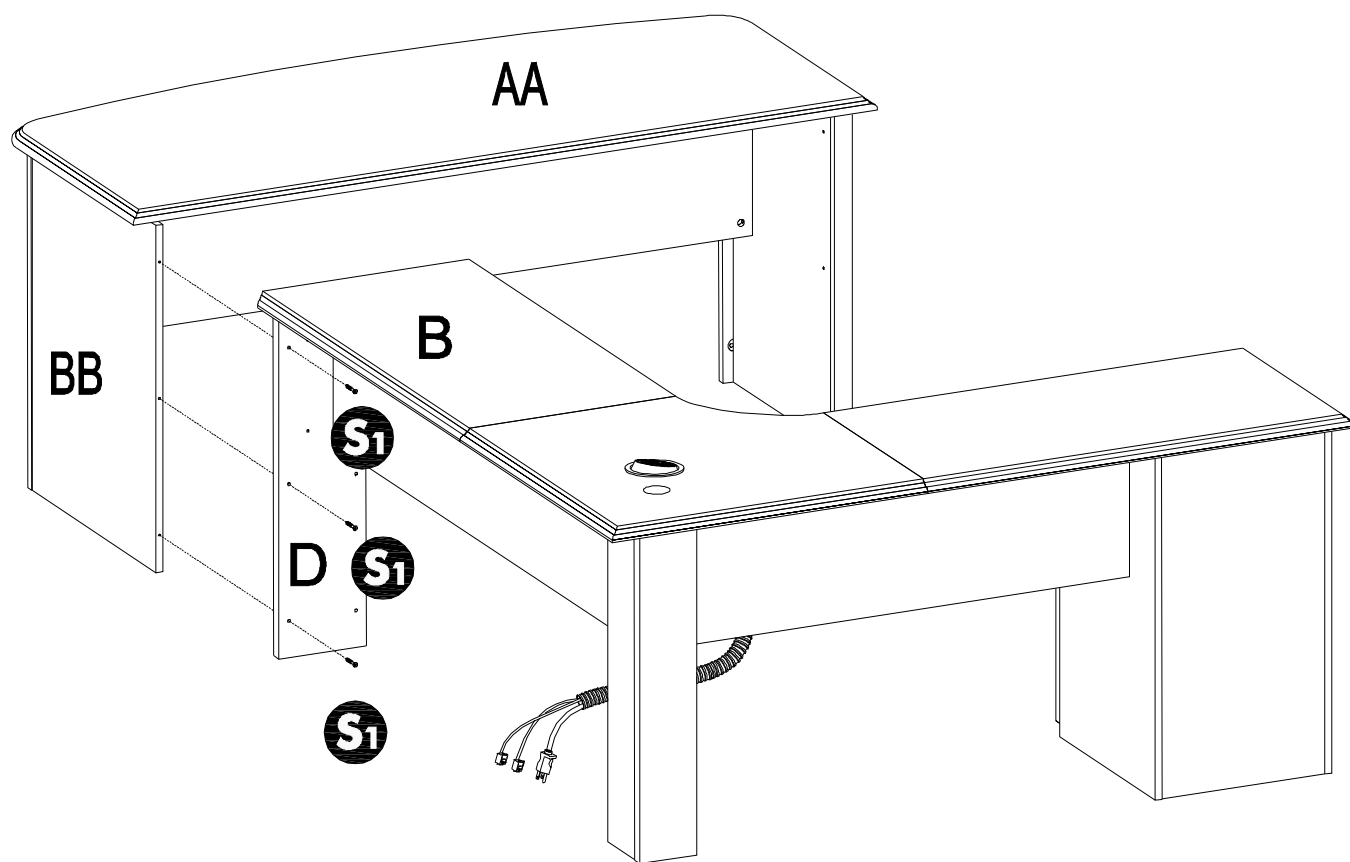
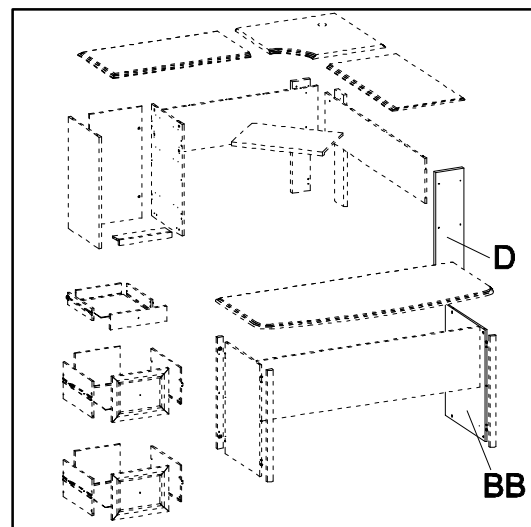
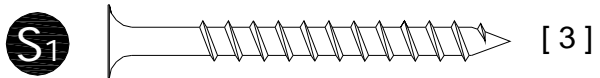



# STEP 80

S5

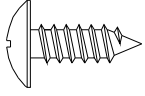

[4]

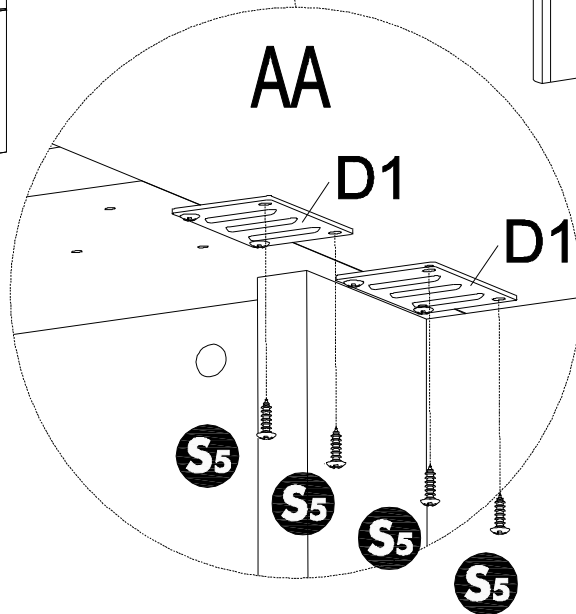
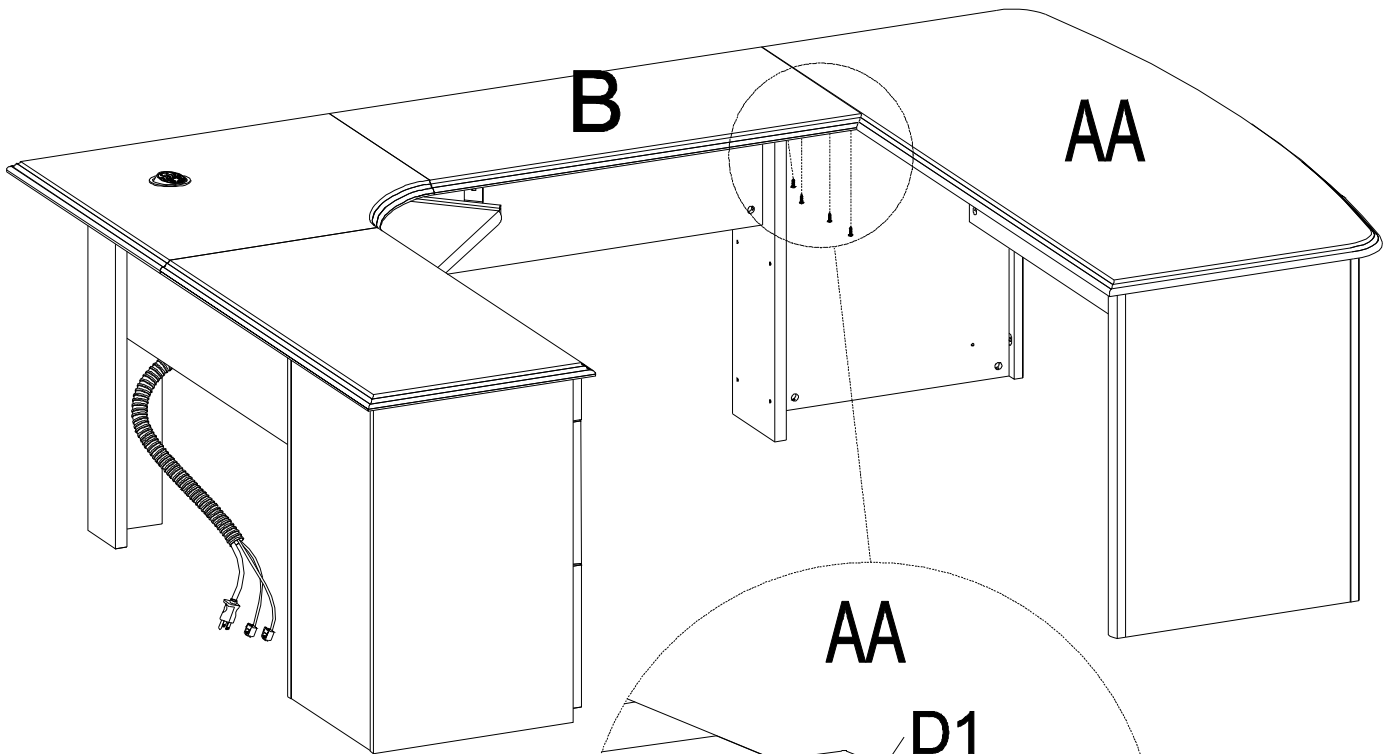
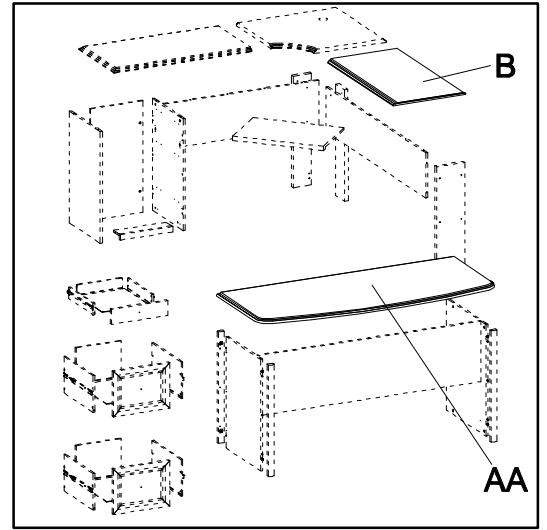

## **Office Depot, Inc. Limited Five Year Product Warranty**

This limited warranty covers the original purchase of new product used for normal commercial, personal or household use. Office Depot, Inc. (ODI) warrants its products will be free from defects in materials and workmanship (normal wear and tear excepted), for five (5) years from the date of purchase, except as provided below. ODI, at its option, will replace with a comparable product, free of charge, any product purchased from it that fails under normal use as a result of such defect. This warranty does not apply to damage caused by fire, accident, negligence, misuse, use other than as stated in product instructions, improper cleaning or other circumstances not directly attributable to defects in materials and workmanship.

**Natural variations occurring in wood or other materials will not be considered defects, and ODI does not warrant the color-fastness or matching of colors, grains, or textures of such materials. This warranty does not apply to: modifications of the product, attachments to the product not approved by ODI, and products that were not installed, used, or maintained in accordance with product instructions and warnings.**

**This warranty has the following exceptions: Fabrics, foam, veneer finishes and other covering materials are warranted for three years from date of purchase.**

Proof of purchase is required in the form of a receipt (copy or original) to validate warranty. Warranty claims without the receipt may be rejected.

If Office Depot, Inc. chooses to provide a refund for such product, it will be fulfilled in the form of an Office Depot Merchandise card. Claims fulfilled in this manner take approximately 30 days to process.

ODI PROVIDES THIS LIMITED WARRANTY IN LIEU OF ALL OTHER WARRANTIES EITHER EXPRESSED OR IMPLIED. EXPRESSLY EXCLUDED ARE ALL WARRANTIES OF FITNESS FOR A PARTICULAR PURPOSE OR MERCHANTABILITY. OFFICE DEPOT'S SOLE OBLIGATION AND THE USER'S EXCLUSIVE REMEDY UNDER THIS WARRANTY SHALL BE LIMITED TO THE REPAIR, REFUND (IN THE FORM OF AN OFFICE DEPOT MERCHANDISE CARD) OR REPLACEMENT AT ODI'S SOLE DISCRETION AND COST, OF PRODUCT OR COMPONENTS.

IN NO EVENT SHALL ODI, ITS AFFILIATES, SUBSIDIARIES OR PARENT COMPANIES BE RESPONSIBLE FOR CONSEQUENTIAL, SPECIAL, OR INCIDENTAL DAMAGES ARISING OUT OF A CLAIM OF DEFECTIVE PRODUCT EVEN IF ODI HAS BEEN ADVISED OF THE POSSIBILITY OF SUCH DAMAGES.

SOME STATES OR PROVINCES DO NOT ALLOW THE EXCLUSION OF IMPLIED WARRANTIES OR LIMITATIONS ON HOW LONG AN IMPLIED WARRANTY LASTS OR THE EXCLUSION OR LIMITATION OF INCIDENTAL OR CONSEQUENTIAL DAMAGES SO THE ABOVE LIMITATIONS MAY NOT APPLY TO YOU. THIS WARRANTY GIVES YOU SPECIFIC LEGAL RIGHTS, AND YOU MAY ALSO HAVE OTHER RIGHTS WHICH MAY VARY BY STATE OR PROVINCE.

THIS WARRANTY APPLIES ONLY TO THE U.S. AND CANADA.

### **Service Instructions**

Please call: 1-800-949-9974 for warranty service.

## **Office Depot, Inc. Garantie limitée de cinq (5) ans**

Cette garantie limitée couvre les produits neufs utilisés dans le cadre d'applications commerciales ou domestiques normales. Office Depot, Inc. (ODI) garantit ses produits contre les défauts de matériel et de main-d'oeuvre (à l'exception de l'usure normale) durant cinq (5) ans à compter de la date d'achat, à l'exception des conditions ci-dessous. ODI, à son gré, remplacera sans frais tout produit défectueux dans des conditions d'usure normale par un produit comparable. La présente garantie ne s'applique pas aux dommages causés par le feu, un accident, la négligence, l'usage abusif, le non-respect des instructions, un nettoyage inapproprié ou autre circonstance non directement attribuable à des défauts de matériel et de main-d'oeuvre.

**Les variations naturelles du bois et des autres matériaux utilisés ne sont pas considérées comme des défauts, et ODI ne garantit pas les couleurs, les grains et les textures de ces matériaux. La présente garantie ne s'applique pas aux produits modifiés, aux fixations non approuvées par ODI et aux produits n'ayant pas été installés, utilisés et entretenus conformément aux instructions et aux avertissements fournis avec le produit.**

**Les tissus, la mousse, les placages et les autres matériaux de recouvrement sont garantis pendant trois (3) ans à compter de la date d'achat.**

Une preuve d'achat sous forme de reçu (original ou photocopie) est exigée pour valider la garantie, sans quoi les réclamations au titre de la garantie peuvent être rejetées.

Si Office Depot, Inc. décide de rembourser le prix d'achat d'un tel produit, le remboursement sera offert sous forme de carte d'achat Office Depot. Veuillez allouer 30 jours pour le traitement des réclamations.

CETTE GARANTIE EST FOURNIE EN LIEU ET PLACE DE TOUTE AUTRE GARANTIE. SONT EXCLUES TOUTES LES GARANTIES D'ADÉQUATION À UN USAGE SPÉCIFIQUE ET DE QUALITÉ SATISFAISANTE. LA SEULE OBLIGATION DE OFFICE DEPOT ET VOTRE SEUL RECOURS EN VERTU DE CETTE GARANTIE SONT LIMITÉS À LA RÉPARATION DU PRODUIT, AU REMBOURSEMENT SOUS FORME DE CARTE D'ACHAT OFFICE DEPOT OU AU REMPLACEMENT DU PRODUIT OU DE COMPOSANTS À SES FRAIS.

ODI, SES FILIALES, SES COMPAGNIES ASSOCIÉES ET SES SOCIÉTÉS MÈRES NE PEUVENT ÊTRE TENUES RESPONSABLES DES DOMMAGES INDIRECTS OU PARTICULIERS INHÉRENTS À UNE RÉCLAMATION POUR PRODUIT DÉFECTUEUX MÊME SI LA POSSIBILITÉ D'UN TEL DOMMAGE A ÉTÉ DÉJÀ ÉTÉ PORTÉE À LA CONNAISSANCE D'ODI.

CERTAINS ÉTATS ET CERTAINES PROVINCES INTERDISANT L'EXCLUSION OU LES RESTRICTIONS DE DURÉE DES GARANTIES IMPLICITES OU L'EXCLUSION DES DOMMAGES INDIRECTS, LES RESTRICTIONS CI-DESSUS PEUVENT NE PAS S'APPLIQUER À VOUS. LA PRÉSENTE GARANTIE VOUS CONFÈRE DES DROITS JURIDIQUES SPÉCIFIQUES ET VOUS POUVEZ DISPOSER D'AUTRES DROITS, LESQUELS PEUVENT VARIER SELON L'ÉTAT OU LA PROVINCE.

CETTE GARANTIE S'APPLIQUE UNIQUEMENT AU CANADA ET AUX ÉTATS-UNIS.

### **Procédure de réclamation en vertu de la garantie**

Pour faire une réclamation, composez le 1 800 949-9974.

## **Office Depot, Inc. Garantía limitada de cinco años para el producto**

Esta garantía limitada cubre la adquisición original de un producto nuevo utilizado con fines comerciales, personales o domésticos normales. Office Depot, Inc. (ODI) garantiza que sus productos estarán exentos de defectos materiales y de fabricación (a excepción de los derivados de un uso y desgaste normal) durante cinco (5) años a partir de la fecha de compra del producto, con la salvedad de lo dispuesto a continuación. ODI, a su discreción, sustituirá de forma gratuita por un producto de características similares cualquier producto adquirido que no soporte unas condiciones de uso normales como consecuencia de dicho defecto. Esta garantía no se aplica a daños causados por incendio, accidente, negligencia, uso incorrecto o cualquier otro uso no especificado en las instrucciones del producto, así como a daños causados por una limpieza incorrecta o por otras circunstancias no atribuibles de forma directa a defectos en los materiales y la fabricación.

**Los cambios atribuibles a la propia naturaleza de la madera u otros materiales no se considerarán defectos y ODI no garantiza la resistencia del color o la coincidencia del color, el veteado o la textura de dichos materiales. Esta garantía no se aplica a: modificaciones del producto, accesorios del producto no aprobados por ODI y productos no instalados, utilizados o mantenidos de acuerdo a las instrucciones y advertencias del producto.**

**Esta garantía cuenta con las siguientes excepciones: el tejido, la espuma, el acabado de chapa y el resto de materiales de revestimiento tienen una garantía de tres años a partir de la fecha de compra.**

Se requiere el recibo de compra (copia u original) para validar la garantía. Los reclamos relacionados con la garantía podrían ser rechazados si no se presenta dicho recibo.

En el caso de que Office Depot, Inc. decida reembolsar dicho producto, este reembolso se realizará mediante una tarjeta comercial de Office Depot. Las reclamaciones realizadas a través de este método se procesarán en aproximadamente 30 días.

ESTA GARANTÍA LIMITADA DE ODI SUSTITUYE A TODAS LAS DEMÁS GARANTÍAS, YA SEAN EXPLÍCITAS O IMPLÍCITAS. QUEDAN EXPRESAMENTE EXCLUIDAS TODAS LAS GARANTÍAS DE ADECUACIÓN PARA UN DETERMINADO FIN O COMERCIALIZACIÓN. LA ÚNICA OBLIGACIÓN DE OFFICE DEPOT Y EL ÚNICO RECURSO DEL USUARIO EN VIRTUD DE ESTA GARANTÍA CONSISTIRÁ EN LA REPARACIÓN, REEMBOLSO (MEDIANTE UNA TARJETA COMERCIAL DE OFFICE DEPOT) O SUSTITUCIÓN, SEGÚN ESTIME OPORTUNO ODI Y ASUMIENDO TODOS LOS COSTES, DEL PRODUCTO O SUS COMPONENTES.

EN NINGÚN CASO ODI, SUS AFILIADOS, SUBSIDIARIOS O EMPRESAS MATRICES SERÁN RESPONSABLES DE DAÑOS DERIVADOS, ESPECIALES O NO INTENCIONADOS PROCEDENTES DE UNA RECLAMACIÓN POR UN PRODUCTO DEFECTUOSO, AUNQUE SE HAYA ADVERTIDO A ODI DE LA POSIBILIDAD DE TALES DAÑOS.

ALGUNAS ESTADOS O PROVINCIAS NO PERMITEN LA EXCLUSIÓN DE GARANTÍAS IMPLÍCITAS, LAS LIMITACIONES SOBRE LA DURACIÓN DE UNA GARANTÍA IMPLÍCITA O LA EXCLUSIÓN O LIMITACIÓN DE DAÑOS DERIVADOS O NO INTENCIONADOS, POR LO QUE ES POSIBLE QUE LAS LIMITACIONES MENCIONADAS NO SE APLIQUEN EN SU CASO. ESTA GARANTÍA OTORGA AL USUARIO DERECHOS LEGALES ESPECÍFICOS; ADEMÁS, ES POSIBLE QUE GOCE DE OTROS DERECHOS QUE VARIAN SEGÚN EL ESTADO O LA PROVINCIA.

ESTA GARANTÍA SE APLICA SÓLO EN EE. UU. Y CANADÁ.

### **Instrucciones de servicio**

Llame al 1-800-949-9974 para obtener más información sobre el servicio de garantía.